

Dimensions

1/2" Drill- For Sizes 4" and Over
3/8" Drill- For Sizes 2" - 3 1/2"
1/4" Drill- For Sizes 1 1/2" and Under

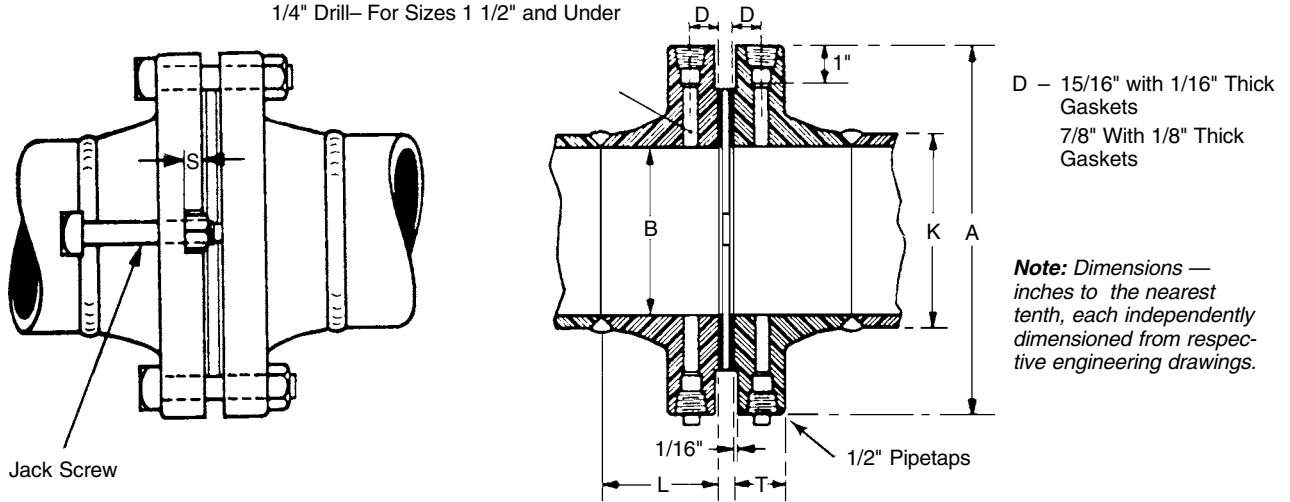

D - 15/16" with 1/16" Thick Gaskets
7/8" With 1/8" Thick Gaskets

Note: Dimensions — inches to the nearest tenth, each independently dimensioned from respective engineering drawings.

Nominal Pipe Size Inches	A	T	K	L	B	S	Diam. of Raised Face	Drilling Template					Approx. Weight Per Union Pounds
								No. of Holes	Diam. of Holes	Diam. of Stud Bolts	Length of Stud Bolts	Bolt Circle	
1'	4.9	1.5	1.32	3.3	1.049	.4	2.8	4	.7	.6	5	3.5	18
1.3'	5.3	1.5	1.66	3.3	1.380	.4	3.2	4	.7	.6	5	3.9	20
1.5'	6.1	1.5	1.90	3.4	1.610	.4	3.7	4	.8	.8	5.3	4.5	25
2'	6.5	1.5	2.38	3.4	2.067	.4	4.3	8	.7	.6	5	5	27
2.5'	7.5	1.5	2.88	3.5	2.469	.5	5.1	8	.8	.8	5.3	5.9	35
3	8.3	1.5	3.50	3.5	3.068	.5	5.8	8	.8	.8	5.3	6.6	43
4	10	1.5	4.50	3.6	4.026	.5	7.1	8	.8	.8	5.3	7.9	66
5	11	1.5	5.56	4	5.047	.5	8.4	8	.9	.8	5.3	9.3	78
6	12.5	1.5	6.63	3.9	6.065	.5	8.5	12	.9	.8	5.3	10.6	106
8	15	1.6	8.63	4.4	7.981	.5	10.6	12	1	.9	5.8	13	152
10	17.5	1.9	10.75	4.6	10.020	.8	12.8	16	1.1	1	6.5	15.3	216
12	20.5	2	12.75	5.1	12.000	.8	15	16	1.3	1.1	7	17.8	327
14	23	2.1	14.00	5.6	13.250	.8	16.3	20	1.3	1.1	7.3	20.3	448
16	25.5	2.3	16.00	5.8	15.25	.8	18.5	20	1.4	1.3	8	22.5	596
18	28	2.4	18.00	6.3	17.25	.8	21	24	1.4	1.3	8.3	24.8	741
20	30.5	2.5	20.00	6.4	19.25	.8	23	24	1.4	1.3	8.5	27	887
24	36	2.8	24.00	6.6	23.25	.8	27.3	24	1.6	1.5	9.5	32	1311

1 1" - 3" sizes will be dual stamped 300/600 lb. ANSI. Above available in all ANSI pressures to 2500 lb., other facings, larger sizes and other materials.

The specifications contained herein are subject to change without notice and any user of said specifications should verify from the manufacturer that the specifications are currently in effect. Otherwise, the manufacturer assumes no responsibility for the use of specifications which may have been changed and are no longer in effect.

Headquarters:

1803 Gears Road, Houston, TX 77067 USA, Phone: 281/260-2190, Fax: 281/260-2191

Gas Measurement Products:

Houston, TX USA Phone 281/260-2190
Thetford, England Phone (44) 1842-82-2900
Kongsberg, Norway Phone (47) 32/286-700
Buenos Aires, Argentina Phone 54 (11) 4312-4736

Integrated Measurement Systems:

Corpus Christi, TX USA Phone 361/289-3400
Kongsberg, Norway Phone (47) 32/286-700
San Juan, Puerto Rico Phone 787/274-3760
United Arab Emirates, Dubai Phone 971 +4/331-3646

Liquid Measurement Products:

Erie, PA USA Phone 814/898-5000
Los Angeles, CA USA Phone 661/702-8660
Slough, England Phone (44) 1753-57-1515
Ellerbek, Germany Phone (49) 4101-3040
Barcelona, Spain Phone (34) 93/201-0989
Moscow, Russia Phone (7) 495/564-8705
Melbourne, Australia Phone (61) 3/9807-2818

Beijing, China Phone (86) 10/6500-2251
Singapore Phone (65) 6861-3011
Chennai, India Phone (91) 44/450-4400

Visit our website at www.fmctechnologies.com