

The **Smith Meter® Ultra<sup>4</sup>™ Liquid Flowmeter** is a four path ultrasonic meter with a Signal Processing Unit (SPU) for measurement of refined petroleum products and crude oils. The **Smith Meter Ultra Series** is the newest entry in the FMC Technologies Measurement Solutions family of metering products which also includes the Ultra<sup>6</sup> for custody transfer liquid measurement applications and the MPU 1200, 800, 600 and 200 gas ultrasonic flowmeters.

### Principle of Operation

The **Ultra<sup>4</sup>** functionality is based on the well-established acoustic transit time principle. This measurement principle documents how ultrasonic pulses are modified as they are transmitted through flowing mediums. An ultrasonic pulse propagating with the flow will experience an increase in velocity while an ultrasonic pulse propagating against the flow will experience a decrease in velocity.

The **Ultra<sup>4</sup>** measures the transit time of the ultrasonic signal that is transmitted. The start of the transmission and arrival of the correct signal is detected by its software.

The **Ultra<sup>4</sup>** transducers are non-intrusive and flush mounted ensuring minimum risk of clogging by residues in the flow. The transducer is fully encapsulated and the transducer housing is manufactured from titanium.

### Ultrasonic Benefits

- **Low Pressure Drop** – Drop is the same as an equal length of straight pipe
- **Low Maintenance** – No moving parts that need replacement due to wear, especially beneficial in severe operating environments
- **Ideal for Problematic Applications** – Non-intrusive parts help avoid product build up on equipment
- **Operational Flexibility** – Bi-directional flow reduces time required to redirect product flow

### Unique Smith Meter Ultra Features

- **High Reproducibility** – To achieve consistent measurement over a wide range of operating conditions
- **Real Time Diagnostics** – WinScreen Software provides real-time logs, trends, signal performance and parameter reports for operation, diagnostics and maintenance
- **Reciprocity** – Exclusive transducer and electronic design that virtually eliminates zero flow offset and



**Transducer and cable protection covers are standard for UL/CUL units but are an option for ATEX units.**

drift to provide long-term measurement stability independent of pressure, temperature, and transducer aging

- **Low Frequency Transducer** – Alternate transducer available on 12" and higher sizes to extend viscosity capabilities
- **Field-Proven Electronics** – The same electronic processor and rugged packing as the FMC Technologies MPU Series gas ultrasonic meters which have been proven in the world's harshest field environments
- **In-line Transducer Replacement** – Designed so there is no need for special tooling or process shut-down to replace a transducer

### Unique Smith Meter Ultra Features for Crude Oil Service

- **Advanced Noise Immunity** – Provides high noise immunity to accurately measure hard to handle high viscosity crude oils with S&W
- **Viscosity Correction** – Four-path configuration with specialized software to correct for the viscous effects of high viscosity crude oils. This allows for optimum accuracy over a wide range of crude oils from condensates to high viscosity crude oils

### Applications

Measurement of refined petroleum products and crude oils for:

- Inventory control
- Line integrity
- Off-loading and on-loading
- Allocation
- Line balancing

# Operating Specifications

## Flow Range\*

Size		Extended Minimum Flow Rate		Normal Flow Rate				Extended Maximum Flow Rate	
Inches	mm	bph	m <sup>3</sup> /h	Minimum		Maximum		bph	m <sup>3</sup> /h
6	150	165	25	450	72	4,500	720	5,500	870
8	200	225	35	800	127	8,000	1,270	9,600	1,530
10	250	350	55	1,250	199	12,500	1,990	15,000	2,380
12	300	500	80	1,900	302	19,000	3,020	22,800	3,620
14	350	680	110	2,000	318	20,000	3,180	24,000	3,820
16	400	925	150	2,800	445	28,000	4,450	33,600	5,340
18	450	1,170	186	3,500	556	35,000	5,560	42,000	6,680
20	500	1,400	225	4,200	668	42,000	6,680	50,000	7,950
22	550	1,670	265	5,000	795	50,000	7,950	60,000	9,540
24	600	1,970	315	6,500	1,033	65,000	10,330	78,000	12,400
26	650	2,270	360	7,500	1,192	75,000	11,920	90,000	14,310
28	700	2,730	435	9,000	1,431	90,000	14,310	108,000	17,170
30	750	3,030	480	10,000	1,590	100,000	15,900	120,000	19,080
32	800	3,480	555	11,500	1,828	115,000	18,280	138,000	21,940
34	850	3,940	625	13,000	2,067	130,000	20,670	156,000	24,800
36	900	4,550	725	15,000	2,385	150,000	23,850	180,000	28,620
40	1,000	5,610	890	18,500	2,941	185,000	29,410	222,000	35,290
48	1,200	7,880	1,255	26,000	4134	260,000	41,340	312,000	49,600

\*For larger sizes consult factory.

### Application

Refined products and crude oils.

### Repeatability

+/- 0.02%

### Linearity

±0.25% over the normal flow range.<sup>1</sup>

### Viscosity Range (cSt)<sup>4</sup>

#### Minimum Viscosity:

Standard: 0.5; Extended Consult Factory

#### Maximum Viscosity:

Meter Size (in)	Standard	Extended
6	800	Consult Factory
8	600	
10	480	
12	330	2,050
14	290	1,760
16	250	1,460
18	220	1,150
20	200	1,000
22	180	870
24	170	740
26	150	650
28	140	570
30	130	500
32	125	450
34	120	400
36	110	350
40	100	280
48	80	190

### Flow

Bidirectional

### Maximum Working Pressure – PSI (bar)

ASME	Carbon Steel	Stainless Steel
150	285 (20)	275 (19)
300	740 (51)	720 (50)
600	1,480 (102)	1,440 (99)
900	2,220 (153)	2,160 (149)

### Temperature Range

Process Fluid Temperature<sup>3</sup>:

- Carbon Steel Housing: -50°F to 250°F (-45°C to 120°C)
  - Stainless Steel Housing: -58°F to 250°F (-50°C to 120°C)
- Ambient temperature: -40°F to 140°F (-40°C to 60°C)

### NACE Compliant

Designed for NACE compliance.

### Multivariable Device

Standard instantaneous flow rate and totalized flow rate.  
Additional information on volume at 60°F (15°C) (as per API) mass flow; reference density and VCF calculation.

### Humidity

Up to 95%, non-condensing.

### Standard Flange Connections

ASME B16.5 RF or RTJ Flanges Class 150, 300 and 600 and 900.  
Consult the factory for other flange type connections.

<sup>1</sup> Consult Factory for review of application if the Dynamic Turndown (TD) is over 100:1 and Reynolds Number (Re No) is below 10,000.

Where: • **Dynamic TD** = (max flow / min flow) x (max viscosity / min viscosity) : 1

• **Re No** = (2,214 x bph) / (meter size in inches x viscosity in cSt) or (13,925 x m3/h) / (meter size in inches x viscosity in cSt)

<sup>2</sup> Consult Factory for higher viscosity applications.

<sup>3</sup> For applications with process fluid temperatures over 158°F (70°) consult factory for proper mounting of electronics.

<sup>4</sup> 1 cSt = 1 mm<sup>2</sup>/s

### **Meter Body and Flanges**

Carbon Steel body and RF or RTJ Flanges, Stainless Steel optional. For other options consult the factory.

### **Transducer**

Piezoelectric element, fully encapsulated in titanium housing.

For other operating conditions and accuracy requirements consult factory.

### **Instrument Power**

#### **DC Instrument Input Power to Field Mounted Electronics**

24 Vdc +15% / -10%, 0.5A.

Power inrush: 8 Amps for < 20mS at 24 Vdc.

The DC power input circuitry is reverse current protected and fused.

Tested to 20 milliseconds power drop without shut down. Meter will always restart orderly after power loss.

#### **AC Instrument Input Power to Field Mounted Electronics**

120/240 Vac continuous, +/- 10%, 12 Watts, 48 to 63 Hz.

Power inrush: 6 Amps for <20mS at 120 Vac.

Power inrush: 3 Amps for <20mS at 240 Vac.

The AC circuitry is fuse-protected.

Power Interruption Tolerance: Interruption of power greater than 100 milliseconds (typical) will cause an orderly shutdown. Tested to 20 milliseconds power drop without shut down. The meter will restart in an orderly progression after a power loss.

### **Electrical Inputs**

#### **Digital Inputs**

2 digital inputs

Type: High speed, optically isolated digital input. The input pulse must rise above V (high. min) for a period of time and then fall below V (low) to be recognized as a pulse.

V (high): 5 Vdc minimum to 28 Vdc maximum.

V (low): 1 Vdc maximum.

Input impedance: 1.67 k $\Omega$ .

#### **Analog Input (4-20mA)**

Up to 2 analog inputs (maximum number of analog inputs and outputs are 2).

Type: Two-wire, 4-20mA current loop receiver, isolated from ground, programmable as to function.

Span Adjustment: Program adjustable.

Input Burden: 50 $\Omega$ .

Resolution: One part in 65,536.

Voltage Drop: 2 Volts maximum.

#### **Analog Input (1-5 Vdc)**

Up to 2 analog inputs (maximum number of analog inputs and outputs are 2).

Type: Two-wire, 1-5 Vdc voltage loop receiver, isolated from ground, programmable as to function.

Span Adjustment: Program adjustable.

Input Burden: 1 M $\Omega$ .

Resolution: One part in 65,536.

#### **Analog Input (Temperature Probe – RTD)**

Up to 2 analog inputs (maximum number of analog inputs and outputs are 2).

Type: Four-wire, 100 $\Omega$  Platinum Resistance Temperature Detector (PRTD).

Temperature Coefficient: @ 32° F: 0.00214  $\Omega/\Omega/^\circ\text{F}$  (0.00385  $\Omega/\Omega/^\circ\text{C}$ ).

Temperature Range: -148°F to 572°F (-100C to 300°C).

Offset: Temperature probe offset is program-adjustable.

Self Calibrating: Lead length compensation that requires no resistance balancing of leads.

### **Electrical Outputs**

#### **Communications**

##### **Ethernet**

ANSI/IEEE 802.3 Ethernet channel operating at 10/100 Mbps.

Modbus/IP at port 502.

Twisted pair (10Base-T/ 100Base-T) or

Optional optical fiber (100Base-FL)

##### **Serial**

Configuration: Multi-drop network.

Data Rate: Selectable asynchronous data (Baud) rates of 2400, 4800, 9600 or 19200 bps.

Data Format: One start bit, One stop bit, eight data bits - no parity.

Line Protocol: Half duplex, full duplex.

Protocol: MODBUS (RTU)

##### **Ports**

Two ports: Selectable from EIA-485 and EIA-232.

##### **EIA-232 Port**

EIA-232 data communication.

##### **EIA-485 Port**

Operating Half-Duplex (2-wire) or Full Duplex (4-wire).

Multi-drop network for EIA-485 data communication. Up to 16 Ultrasonic Flowmeters can be connected onto the same Bus/ twisted pair.

##### **Pulse Output**

4 pulse outputs.

Type: Open collector type output. User- selectable pulse units.

Volume output selectable for rate and incremental volume.

Single or Dual Quadrature (outputs 90 electrical degrees out of phase).

Polarity: Selectable (Normally Open or Normally Closed).

Switch Blocking Voltage (Switch Off): 30Vdc maximum.

Load Current (Switch On): 10mA with 0.6 volts drop.

Frequency Range: 0 to 5kHz.

Duty Cycle: 50/50 (on/off).

### **Digital Outputs**

2 digital outputs.

Type: Optically-isolated solid state output. User-programmable as to function.

Polarity: Programmable (Normally Open or Normally Closed)\*.

Switch Blocking Voltage: 30 Vdc maximum.

Load Current: 150mA maximum with 0.6 volt drop.

\*Note: Power-down normally open.

### **Analog Output (4-20mA)**

Up to 2 analog outputs (maximum number of analog inputs and outputs are 2).

Type: Two-wire, 4-20mA current loop transmitter, isolated from ground, programmable as to function.

Span Adjustment: Program adjustable.

Accuracy: +/-0.025% of full scale.

Resolution: One part in 65,536.

Voltage Burden: 4 volts maximum.

Maximum Load Resistance: 250Ω.

### **Analog Output (1-5 Vdc)**

Up to 2 analog outputs (maximum number of analog inputs and outputs are 2).

Type: Two-wire, 1-5 Vdc voltage loop transmitter, isolated from ground, programmable as to function.

Span Adjustment: Program adjustable.

Accuracy: +/-0.025% of full scale.

Resolution: One part in 65,536.

## **Approvals**

---

### **Hazardous Locations Classification**

#### **Model USI-L (Housing and Electronics)**

##### **ATEX (European Community)**

NEMKO 05 ATEX 1244

EEx d IIB T5 Tamb = -55°C to 60°C IP66

##### **IEC Ex (Global Approach)**

IEC Ex NEM 05.0007

Ex d IIB T5 Tamb = -55°C to 60°C IP66

##### **CSA-US (North American)**

01CSA1112186

For use in Class I, Div. 1, Group C & D and Class I, Zone 0, Groups IIB, T5 locations

Ex d IIB T5 Tamb -55°C to 60°C IP 66 Type 4X

#### **Model (Ultrasonic Transducer)**

##### **ATEX (European Community)**

DEMKO 05 ATEX 05.11224

Ex d IIB T5 Tamb = -40°C to 70°C IP 66

##### **IEC Ex (Global Approach)**

IEC Ex DEMKO 05.0014

Ex d IIB T5 Tamb = -40°C to 70°C IP 66

##### **UL/CUL (North American)**

UL File E23545

Class I, Division 1, Groups C & D

Class I, Zone 1, Groups IIB T5

Ex d IIB T5 Tamb = -40°C to 70°C Type 4X

##### **CRN**

0F10758.2

## Dimensions and Weight

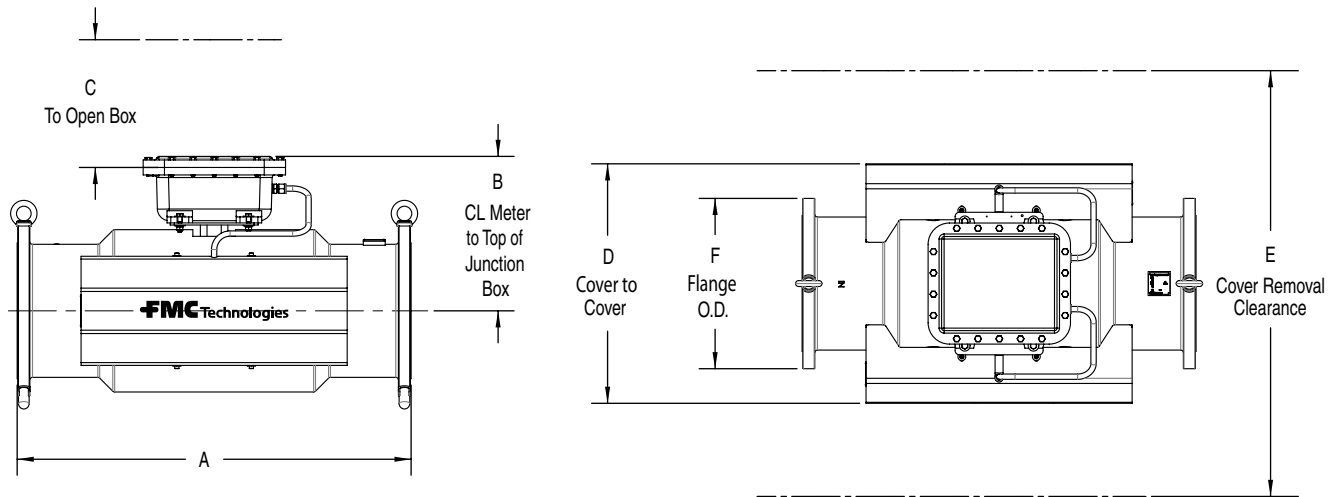

Inches (mm) and Pounds (kg)

### ASME Class 150 Flange\*

Size	A	B	C	D	E	F	Weight - lb (kg)
6"	29.0" (737)	12.4" (314)	20.0" (508)	19" (483)	34.0" (864)	11.0" (279)	510 (231)
8"	33.5" (850)	13.5" (343)	20.0" (508)	21" (533)	36.0" (914)	13.5" (343)	690 (313)
10"	37.0" (940)	14.5" (368)	20.0" (508)	23" (584)	38.0" (965)	16.0" (406)	950 (431)
12"	39.0" (990)	15.3" (387)	20.0" (508)	25" (635)	40.0" (1,016)	19.0" (483)	1,075 (488)
14"	C/F	C/F	C/F	C/F	C/F	C/F	C/F
16"	43.3" (1,100)	16.9" (429)	20.0" (508)	30.0" (762)	45.0" (1,143)	23.5" (597)	1,480 (671)
18"	C/F	C/F	C/F	C/F	C/F	C/F	C/F
20"	C/F	C/F	C/F	C/F	C/F	C/F	C/F

### ASME Class 300 Flange\*

Size	A	B	C	D	E	F	Weight - lb (kg)
6"	29.0" (737)	12.4" (314)	20.0" (508)	19" (483)	34.0" (864)	12.5" (318)	540 (245)
8"	33.5" (850)	13.5" (343)	20.0" (508)	21" (533)	36.0" (914)	15.0" (381)	720 (327)
10"	37.0" (940)	14.5" (368)	20.0" (508)	23" (584)	38.0" (965)	17.5" (445)	1,020 (463)
12"	39.0" (990)	15.3" (387)	20.0" (508)	25" (635)	40.0" (1,016)	20.5" (521)	1,160 (526)
14"	C/F	C/F	C/F	C/F	C/F	C/F	C/F
16"	43.3" (1,100)	16.9" (429)	20.0" (508)	30.0" (762)	45.0" (1,143)	25.5" (648)	1,600 (726)
18"	C/F	C/F	C/F	C/F	C/F	C/F	C/F
20"	C/F	C/F	C/F	C/F	C/F	C/F	C/F

C/F – Consult Factory

\*For larger sizes consult factory

**Note:** Dimensions – inches to the nearest tenth (millimetres to the nearest whole mm), each independently dimensioned from respective engineering drawings.

## Dimensions and Weight

### ASME Class 600 Flange\*

Size	A	B	C	D	E	F	Weight - lb (kg)
6"	29.0" (737)	12.4" (314)	20.0" (508)	19" (483)	34.0" (864)	14.0" (356)	580 (263)
8"	33.5" (850)	13.5" (343)	20.0" (508)	21" (533)	36.0" (914)	16.5" (419)	770 (349)
10"	37.0" (940)	14.5" (368)	20.0" (508)	23" (584)	38.0" (965)	20.0" (508)	1,145 (519)
12"	39.0" (990)	15.3" (387)	20.0" (508)	25" (635)	40.0" (1,016)	22.0" (559)	1,300 (590)
14"	C/F	C/F	C/F	C/F	C/F	C/F	C/F
16"	43.3" (1,100)	16.9" (429)	20.0" (508)	30.0" (762)	45.0" (1,143)	27.0" (686)	1,830 (830)
18"	C/F	C/F	C/F	C/F	C/F	C/F	C/F
20"	C/F	C/F	C/F	C/F	C/F	C/F	C/F

C/F – Consult Factory

\*For larger sizes consult factory

### ASME Class 900 Flanges and RTJ Flanges

Consult factory for all sizes.

**Note:** Dimensions – inches to the nearest tenth (millimetres to the nearest whole mm), each independently dimensioned from respective engineering drawings.

## Catalog Code

The following guide defines the correct ultrasonic flowmeter for a given application and the respective catalog code. This code is part of the ordering information and should be included on the purchase order.

### Standard Configuration:

Instrument input power: 24 Vdc or 120/240 Vac

2 Digital inputs: High-speed, optically isolated

2 Digital outputs: Optically isolated solid-state output

4 Pulse outputs: Optically Isolated Solid-state Output (0 - 5kHz) User-programmable pulse units, pulse rates. Single or Dual Quadrature

Ethernet: Twisted pair (10Base-T/100Base-T)

Serial: 2 Programmable ports, customer selectable for EIA-485 and EIA-232

1	2	3	4	5	6	7	8	9	10	11	12
4	RU	0	6	1	1	S	0	1	1	C	S

#### Position 1: Code

4 - Ultra<sup>4</sup>

#### Position 2: Certification

##### Refined Products and Light Crude Oils

RU - US Model – Explosion Proof Certification

RA - European Model – ATEX/IECEX Certification

##### Crude Oil

CD - US Model – Explosion Proof Certification

CA - European Model – ATEX/IECEX Certification

#### Positions 3 and 4: Diameter

06"	24"
08"	26"
10"	28"
12"	30"
14"	32"
16"	34"
18"	36"
20"	40"
22"	48"

#### Positions 5: End Connections

- 1 - Class 150 ASME Flanges
- 2 - Class 300 ASME Flanges
- 3 - Class 600<sup>3</sup> ASME Flanges
- 4 - Class 900 ASME Flanges
- 5 - Class 150 RTJ Flanges
- 6 - Class 300 RTJ Flanges
- 7 - Class 600 RTJ Flanges
- 8 - Class 900 RTJ Flanges

#### Position 6: Materials

- 1 - Carbon Steel
- 2 - 300 Series Stainless Steel
- X - Special

#### Position 7: Transducer

- S - Standard Titanium
- X - Special

#### Positions 8: Optional Interface

- 0 - Not Required

#### Position 9: Analog Input<sup>2</sup>

(e.g. Temperature and Pressure)

- 0 - Not Required
- 1 - 1 Analog Input (4-20 mA)
- 2 - 2 Analog Inputs (4-20 mA)
- 3 - 1 Analog Input (1-5 Vdc)
- 4 - 2 Analog Inputs (1-5 Vdc)
- 5 - 1 Analog Inputs RTD
- 6 - 1 Analog Input (4-20 mA) and 1 Analog Input (RTD)
- 7 - 1 Analog Input (1-5 Vdc) and 1 Analog Input (RTD)

#### Position 10: Analog Output<sup>2</sup>

(e.g. To DCS or Indicator)

- 0 - Not Required
- 1 - 1 Analog Output (4-20 mA)
- 2 - 2 Analog Outputs (4-20 mA)
- 3 - 1 Analog Output (1-5 Vdc)
- 4 - 2 Analog Outputs (1-5 Vdc)

#### Position 11: Mechanical Certification

- B - ASME B31.3
- P - PED
- C - CRN
- X - Special

#### Position 12: Software

- S - Standard

<sup>2</sup> Maximum number Analog I/O ports two (2).

<sup>3</sup> Consult the factory for 16" diameter.

Revisions included in SSLS002 Issue/Rev. 0.4 (6/11)

Page 2: Revised Viscosity Range and Temperature Range; Footnote 4 added.

Page 4: CRN 0F10758.2 added to Approvals.

Page 7: Catalog Code - Position 6 Materials - 300 Series removed from 1.

The specifications contained herein are subject to change without notice and any user of said specifications should verify from the manufacturer that the specifications are currently in effect. Otherwise, the manufacturer assumes no responsibility for the use of specifications which may have been changed and are no longer in effect.

Contact information is subject to change. For the most current contact information, visit our website at [www.fmctechnologies.com/measurementsolutions](http://www.fmctechnologies.com/measurementsolutions) and click on the "Contact Us" link in the left-hand column.

**Headquarters:**

500 North Sam Houston Parkway West, Suite 100, Houston, TX 77067 USA, Phone: +1 (281) 260 2190, Fax: +1 (281) 260 2191

**Measurement Products and Equipment:**

**Erie, PA USA** +1 (814) 898 5000

**Ellerbek, Germany** +49 (4101) 3040

**Barcelona, Spain** +34 (93) 201 0989

**Beijing, China** +86 (10) 6500 2251

**Buenos Aires, Argentina** +54 (11) 4312 4736

**Burnham, England** +44 (1628) 603205

**Dubai, United Arab Emirates** +971 (4) 883 0303

**Los Angeles, CA USA** +1 (310) 328 1236

**Melbourne, Australia** +61 (3) 9807 2818

**Moscow, Russia** +7 (495) 5648705

**Singapore,** +65 6861 3011

**Integrated Measurement Systems:**

**Corpus Christi, TX USA** +1 (361) 289 3400

**Kongsberg, Norway** +47 (32) 286700

**Dubai, United Arab Emirates** +971 (4) 883 0303

**Visit our website at [www.fmctechnologies.com/measurementsolutions](http://www.fmctechnologies.com/measurementsolutions)**