

The **Smith Meter® microFlow.net™ Gas** is a microprocessor based instrument with Ethernet capability. It is designed to monitor and control single product, single meter flow. The unit can operate either as a stand-alone instrument or be part of system where it communicates with an automation or SCADA system.

## Features

- Single Meter, single product electronic flow computer
- Ethernet communications port
- Three multi-drop EIA-485 or EIA-232 communications ports
- Continuous monitoring of critical functions
- User configurable inputs and outputs
- Programmable language/messages
- Event logging/audit trail
- Configurable batch report
- Calculations for AGA-5, AGA-7, AGA-8, ISO6976, AGA 10 and GPA 2172
- Ten point meter factor curve
- Explosion-proof
- Display backed-up per OIML
- MPU (ultrasonic) meter communications
- Three security levels
- Boolean/Algebraic expressions
- Modbus (Modicon Modbus RTU)
- Pulse Security Level B
- Adjustable Display Contrast
- Forward and Reverse flow totalization
- Minimum 35 day flow data storage of hourly and daily records

## Applications

Applications include any size gas pipeline for single product, single meter flow. This self contained EXP unit continuously computes, totalizes, and displays Gross, Gross at Standard Volume, Mass, and Energy. The microFlow also offers run time displays, which provide all (rate, batch, temp, etc.) critical flow information.



**Smith Meter microFlow.net**

The microFlow.net calculates gas flow in accordance to the American Gas Association (AGA) and American Petroleum Institute (API). The microFlow.net is capable of interfacing to the meter in one of three programmable ways:

- Pulse input only (used for any pulse generating meter environments)
- Communications input only (serial TCP/IP modbus) for FMC MPU gas ultrasonic meter only
- Communications primary and pulse input backups for FMC MPU gas ultrasonic meter only

The microFlow.net maintains archives to API Chapter 21.1 requirements.

## Standard Features

### Density Correction

The density correction feature provides the customer with the ability to correct the volume of product delivered at varying densities. Density can be obtained through a 4-20 mA input or calculated per AGA-8.

### **MPU Meter Interface**

The microFlow.net will support an interface to the FMC MPU Gas ultrasonic meter. The interface will either be a pulse input connected directly where each pulse represents an increment of volume or the volume will be read directly from the meter via modbus over a serial TCP/IP connection. The modbus port will provide volume, temperature, pressure (read or write), flow rate and alarm status plus diagnostic data.

### **Dual Pulse Security**

This feature provides continuous monitoring and error indication alarm of pulse transmission for the meter per API Petroleum Measurement Standard, Chapter 5.5, Level B, and Institute of Petroleum Standard, IP 252/76, Part XIII, Section 1, Level B.

### **Sampler Operation**

The microFlow.net will support a sampler by providing a discrete I/O output signal which will produce a pulse of programmable width each time a sample is to be taken. The sampling frequency will be programmable by either volume or time. The parameters used to configure the sampler are in the General Purpose directory. The number of samples are kept in a running totalizer and stored in the microFlow. The total is automatically reset at the end of a batch. The sampler can be enabled/disabled through the keypad in the program mode.

### **Boolean and Algebraic Processing**

The microFlow.net provides the customer the flexibility to set-up inputs and outputs for tasks that are not standard in the unit. Through Boolean processing, relays can be turned on and off through equations and events set-up by the customer. For example, a relay is required to close when flowrate is zero. This can be set-up using Boolean processing and does not require special software from the manufacturer.

Algebraic processing is also an area the customer can use to do simple mathematical calculations not in the unit. These calculations can then be used on the configurable reports or delivery display for the current batch being run by the unit.

### **Communications**

The microFlow.net is equipped with three standard programmable communication ports that can be set up to be either EIA-232 or EIA-485 compatible communication ports, with baud rates up to 38,400 bps. In addition to these three communication ports an Ethernet port is available which supports modbus and Smith minicomputer host protocols.

### **Hardware Options**

#### **OIML Display**

The microFlow.net is designed to have two display options. The standard display option will operate until the power is lost and then will go blank. The OIML display option is the same display but when the power is lost, the display will maintain the data for reading by an operator for up to fifteen minutes.

### **Specifications**

---

Stability: 0.1°F(0.06°C)/year

Flow Totalization within one pulse of input frequency.

#### **Electrical Inputs**

##### **AC Instrument Input Power**

Dual Voltage input 115 or 230 VAC via Switch, 50/60 Hz

Power consumption: Approximately 9 watts.

Power Interruption Tolerance: Interruption of power greater than 0.05 seconds (typical) will cause an orderly shut-down of the microFlow.net and the control valve will be immediately signaled to close.

##### **DC Instrument Input Power**

Voltage: 24 VDC

Power consumption: Approximately 9 watts.

The DC power input circuitry is reverse current protected.

##### **Digital (Meter Signal) Pulse Inputs**

Type: Optically-isolated solid-state voltage sensors

Quantity: Two

Input Voltage Range: 5 to 28 Vdc compatible

Pickup Voltage: 5 Vdc minimum

Drop-Out Voltage: 1 Vdc maximum

Current at Maximum Voltage: 20 mA maximum

Input Level Duration: 83 μS minimum

##### **Digital Control Inputs**

Type: Optically-isolated solid-state voltage sensors

Quantity: Three

Input Voltage Range: 5 to 28 Vdc compatible

Pickup Voltage: 5 Vdc minimum

Drop-Out Voltage: 1 Vdc maximum

Current at Maximum Voltage: 20 mA maximum

Input Level Duration: 120 mSec minimum

Batch Reset: input must be held on high voltage for 300ms to ensure a reset state

##### **Analog Inputs**

Type: 20-bit analog to digital converters

Function: One RTD, one 4-20 mA

Temperature (RTD – Resistance Temperature Device)

Type: Four-wire 100Ω platinum resistance temperature detector (PRTD)

PRTD Temperature Coefficient @ 32°F to be: 0.00214 Ω/Ω/°F (0.00385 Ω/Ω/°C)

Temperature Range: -148°F to +572°F (-100°C to +300°C)

Temperature Measurement Accuracy: ±0.72°F (±0.4°C) over the specified range

##### **Current (4-20 mA) Input**

Type: Two-wire, 4-20 mA current loop receiver, programmable as to function.

Span Adjustment: Program adjustable  
 Input Burden: 50Ω  
 Accuracy: ±0.025% of range  
 Resolution: One part in 1,048,576  
 Voltage Drop: Two volts maximum  
 Sampling Rate: One Sample/300 mSec minimum.

**Electrical Outputs**

**DC Power**

12 Vdc +/-5%, 180 mA maximum, short circuit protected.

**AC Digital Outputs**

Type: Optically isolated solid-state output user-programmable as to function

Quantity: Four

Load Voltage Range: 90 – 280 Vac (rms) 48 – 63 Hz

Steady-State Load Current Range: 0.05A (rms) minimum to 0.50 amp (rms) maximum into an inductive load.

Leakage Current at Maximum Voltage Rating: 2.5 mA maximum at 240 Vac.

On-State Voltage Drop: 2.0 Vac at maximum load

**DC Digital Outputs**

Type: Optically-isolated solid-state output user-programmable as to function

Quantity: Two

Switch Blocking Voltage: 30 Vdc maximum

Load Current: 150 mA maximum with 0.6 volt drop

Power down normally open

**Pulse Output**

Type: Optically-isolated solid state open-collector output. Pulser output units are program selectable through the microFlow.net keypad or communications.

Switch Blocking Voltage (Switch off):30 Vdc maximum.

Load Current (Switch On): 10 mA with 0.6 volts drop.

Frequency Range: 0 to 3000Hz

Duty Cycle: 50/50 (on/off)

**Environmental**

**Ambient Operating Temperature**

-13°F to 140°F (-25°C to +60°C)

**Humidity**

5 to 95% with condensation

**Enclosure**

Explosion-proof (NEMA7, Class I, Groups C and D) and watertight (NEMA4X), IP 65

**Approvals**

**UL/CUL**

Class I, Groups C & D; Class II, Groups E, F & G

Class I, Zone1, Aex d [ib] IIB T6

UL Enclosure 4X, CSA Enclosure 4, Pending

**ATEX**

EEx d [ib] IIB T6

DEMKO 04 ATEX 0403315

**IEC**

IEC Ex UL 04.0007

Ex d [ib] T6 IP65 Tamb -25° C to +60° C

**Electromagnetic Compatibility**

Complies with the European Community Electromagnetic Capabilities (CE Mark) Requirements as per EN50082-2: 1994

**Communications**

Number of ports: Three plus Ethernet

Configuration: EIA-485 Four-wire or two wire Multi-drop network with optional termination resistor or EIA-232 Three-wire communications link.

Data Rate: Programmable asynchronous data (Baud) rate from 2,400 to 38,400 bps

Data Format: Fixed at one start bit, one stop bit, eight data bits, and no parity.

Line Protocol: Full duplex, no echo character.

Data Structure: ASCII character oriented, modeled after ISO Standard 1155

Protocol: Smith ASCII LRC, Smith ASCII CR, Smith ASCII binary

Ethernet: 10/100 Base TRJ-45

8 or 10 pin UTP (unshielded twisted pair) connector

**microFlow.net – Modeling**

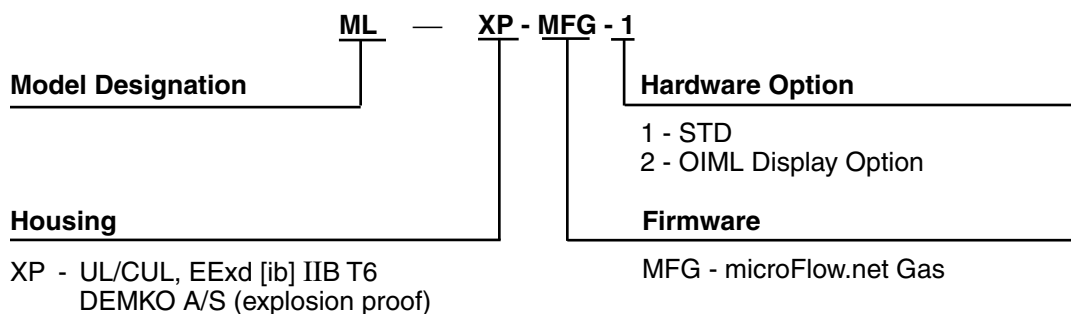

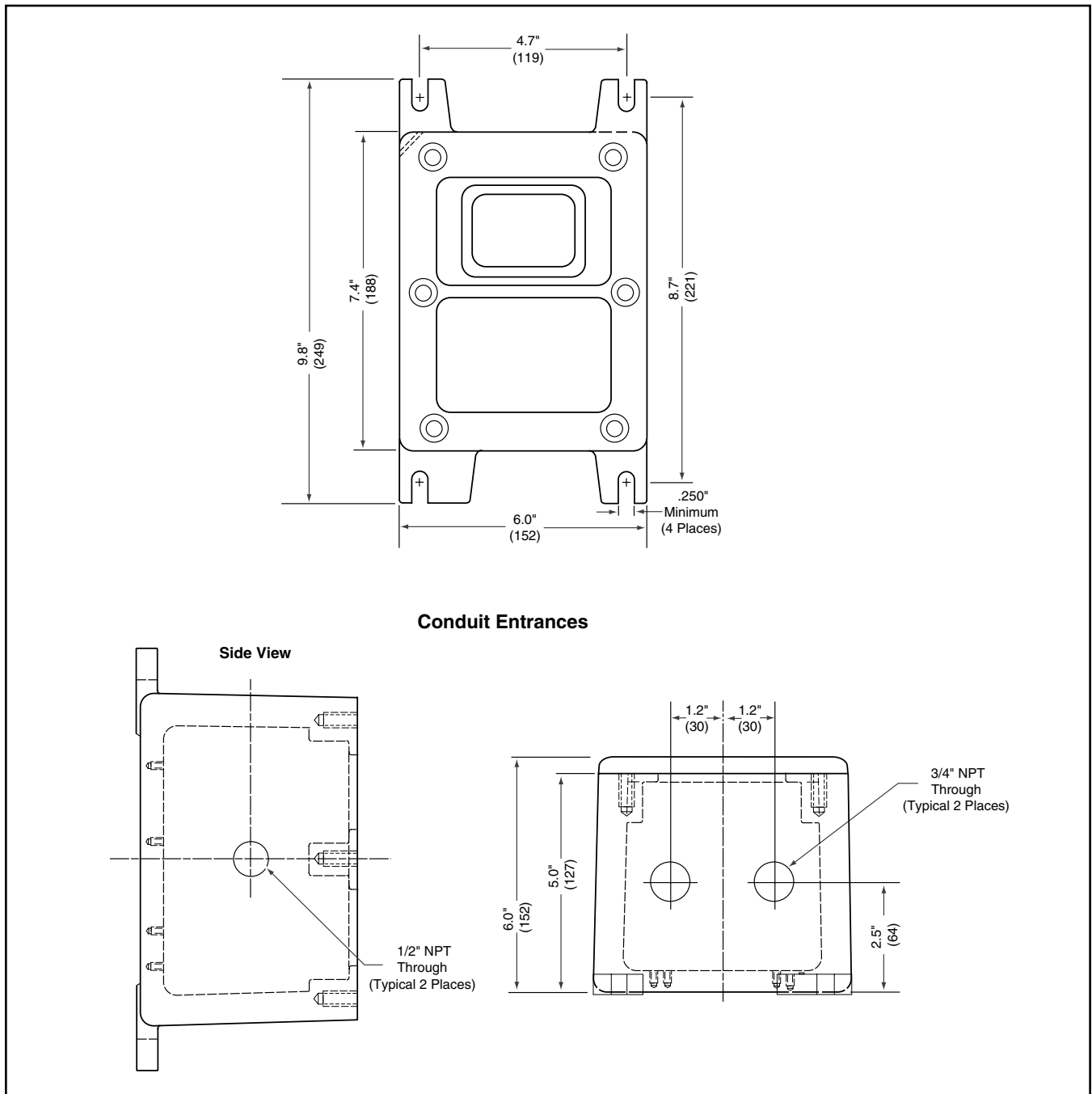

**Figure 1 – Explosion-proof Housing**

**Note:** Dimensions – Inches to the nearest tenth (millimetres to the nearest whole mm), each independently dimensioned from respective engineering drawings.

The specifications contained herein are subject to change without notice and any user of said specifications should verify from the manufacturer that the specifications are currently in effect. Otherwise, the manufacturer assumes no responsibility for the use of specifications which may have been changed and are no longer in effect.

**Headquarters:**

500 North Sam Houston Parkway West, Suite 100, Houston, TX 77067 USA, Phone: +1 (281) 260-2190, Fax: +1 (281) 260-2191

**Gas Measurement Products:**

Houston, TX USA +1 (281) 260-2190  
 Thetford, England +44 (1842) 82-2900  
 Kongsberg, Norway +47 (32) 286-700  
 Buenos Aires, Argentina +54 (11) 4312-4736

**Integrated Measurement Systems:**

Corpus Christi, TX USA +1 (361) 289-3400  
 Kongsberg, Norway +47 (32) 286-700  
 San Juan, Puerto Rico +1809 (787) 274-3760  
 United Arab Emirates, Dubai +971 (4) 331-3646

**Liquid Measurement Products:**

Erie, PA USA +1 (814) 898-5000  
 Los Angeles, CA USA +1 (310) 328-1236  
 Slough, England +44 (1753) 57-1515  
 Ellerbek, Germany +49 (4101) 304-0  
 Barcelona, Spain +34 (93) 201-0989  
 Moscow, Russia +7 (495) 564-8705  
 Melbourne, Australia +61 (3) 9807-2818

Beijing, China +86 (10) 6500-2251  
 Singapore +65 6861-3011  
 Chennai, India +91 (44) 450-4400

Visit our website at [www.fmctechnologies.com/measurementsolutions](http://www.fmctechnologies.com/measurementsolutions)