

## 2" LT-11

Bulletin SS01101L Issue/Rev. 0.3 (4/18)

### Smith Meter® 200 Liter Repeat Batch Meter Packages

The **Smith Meter® LT-11 Repeat Batch Meter Packages** are used for high-speed repeat filling of 200 liter containers. They incorporate a rotary vane positive displacement meter and a mechanically-linked batching counter and valve. They are fitted with a combination air eliminator/strainer, hose, and nozzle. These meter packages provide accurate, reliable metering of petroleum products with minimum pressure drop. Alternative materials for repeat batching of chemicals are available. The proven Smith Meter design is light in weight, compact, and easy to install. These meter packages meet all legal accuracy requirements and maintain accuracy over extended periods under severe operating conditions.



#### Features

- **Compact, Versatile Design** – Can be readily fitted into most any installation.
- **Ball Bearing Construction** – Improves meter accuracy and service life.
- **Low Pressure Drop Meter** – Results in low meter slippage and, thus, superior meter accuracy.
- **Simple, Rugged Calibrator** – Externally-adjusted with a screwdriver and readily sealed to prevent unauthorized tampering.

### Principle of Operation

#### Repeat Batching

Operation of the Smith Meter® Barrel-Filling Repeat Batching Meter Package is initiated by manually actuating the mechanical linkage between the valve and batching counter. This action permits dispensing of a fixed quantity of 200 liters of liquid. System shut-off is automatic.

At the start of each batch, the three-digit batching counter display will read '000'. When the 200 liter batch filling operation begins, the counter will down-count from "000" (e.g. 199, 198, etc.) until the operation is complete. Should the operation be interrupted before the full 200 liter batch has been delivered, the operator has the ability to manually preset the remaining volume required to complete the transaction.

#### Air Elimination

A combination air eliminator/strainer is attached to the meter inlet. It consists of an enlarged housing, containing a float, connected through linkage to an air vent located in the upper part of this unit. When air enters, the float falls, opening the air vent. The Model T2A-1 Air Eliminator has two vents. One vent discharges to atmospheric pressure<sup>1</sup>. The other vent, connected via tubing to the valve, closes an integral back pressure valve to retain or stop liquid flow whenever air is present in the air eliminator chamber. Once the air has been eliminated, the back pressure valve automatically re-opens, permitting liquid to begin flowing again.

<sup>1</sup> This should always be vented to a tank or other container.

## Operating Specifications

### Maximum Flow Rate

100 USGPM (375 L/min).

Minimum Flow Rate – Typical Performance							
Linearity <sup>2</sup>	Units	Viscosity (centipoise - mPa•s)					
		0.5	1	5	20	100	400
±0.15	USG/min	30	20	8	2.0	0.4	0.10
	L/min	113	75	30	7.6	1.5	0.38
±0.25	USG/min	20	15	6	1.5	0.3	0.08
	L/min	75	57	22	5.7	1.1	0.30
±0.50	USG/min	15	10	4	1.0	0.2	0.05
	L/min	57	38	15	3.8	0.8	0.19

### Pressure Drop<sup>3</sup>

Meter, Air Eliminator, and Valve: 3.0 psi (21 kPa) at 100 USG/min (375 L/min) for 4 mPa•s, 0.85 sp. gr., liquid.

### Maximum Viscosity

50 mPa•s<sup>4</sup> (250 SSU). For higher viscosities, consult factory.

### Temperature Range

Standard: Viton/Buna Seals: 10°F to 150°F (-12°C to 65°C).

### Maximum Working Pressure

150 psig (1,034 kPa)

### Meter Gearing

One U.S. gallon or one dekalitre per revolution of meter calibrator output shaft.

### First Stage Preset

Factory set nine liters but any value for zero to twenty liters can be set if specified at time of order.

<sup>2</sup> Based on a maximum flow rate of 100 USGPM (375 L/min).

<sup>3</sup> Pressure at the meter must be at least 20 psig (138 kPa) to fully open the air-check valve.

<sup>4</sup> 1 mPa•s = 1 centipoise (cP).

<sup>5</sup> Standard.

<sup>6</sup> Specify: minimum/normal/maximum.

<sup>7</sup> Standard seals supplied unless optional material specified.

<sup>8</sup> Polytetrafluoroethylene (PTFE).

## Materials of Construction

	Housing	Internals	Seals
<b>Meter:</b> T-11	Cast Iron	Iron, Steel, Stainless Steel, Aluminum, Bronze	Viton <sup>5</sup> or PTFE <sup>8</sup>
<b>Faucet:</b> SP2S	Cast Iron	Steel, Iron, Aluminum	Buna N <sup>5</sup> or Viton
<b>Air Eliminator:</b> T2A1	Aluminum	Iron, Steel, Aluminum	Buna N <sup>5</sup> or Viton
<b>Hose Standard:</b> 1.5 or 2"	Brass Fittings	Neoprene with Buna-N Internal Coating	
<b>Nozzle</b>	Aluminum	Aluminum, Steel	Buna N <sup>5</sup> or Viton

## Inlet / Outlet Positions

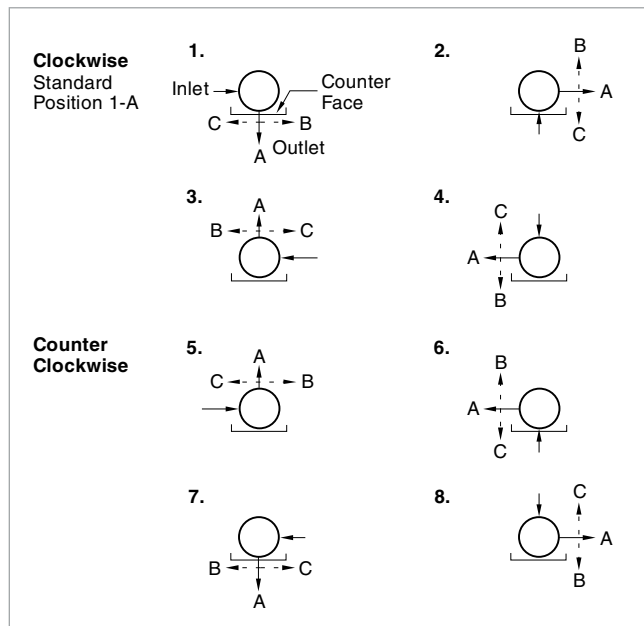

**Note:** A, B, or C denotes orientation of valve outlet.

## Approximate Weight:

103 lbs. (47 Kg.)

## Dimensions

### Inches (Millimeters)

**Note:** Dimensions – inches to the nearest tenth (millimeters to the nearest whole mm), each independently dimensioned from respective engineering drawings.

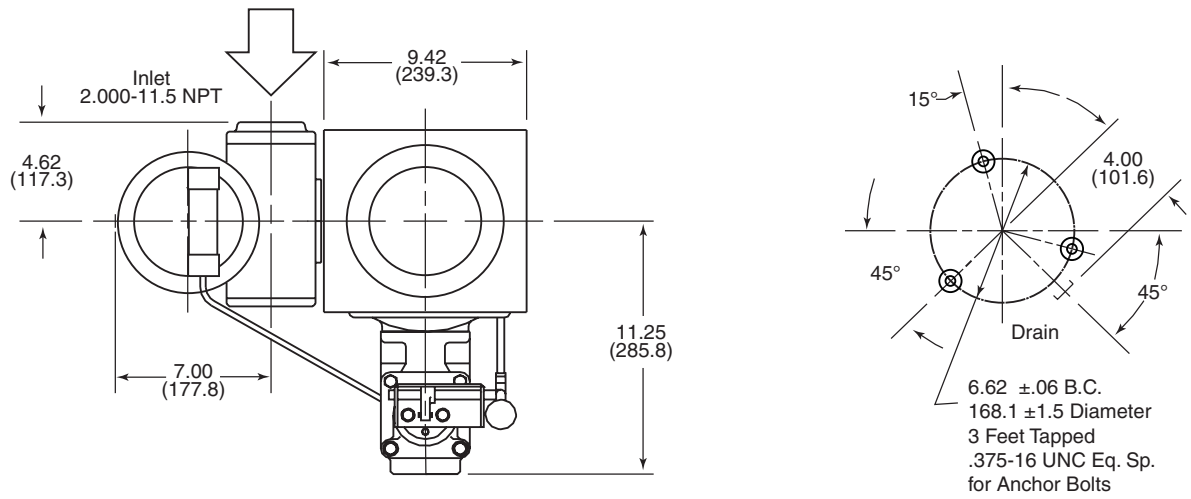

T2A-1 Air Eliminator / Strainer

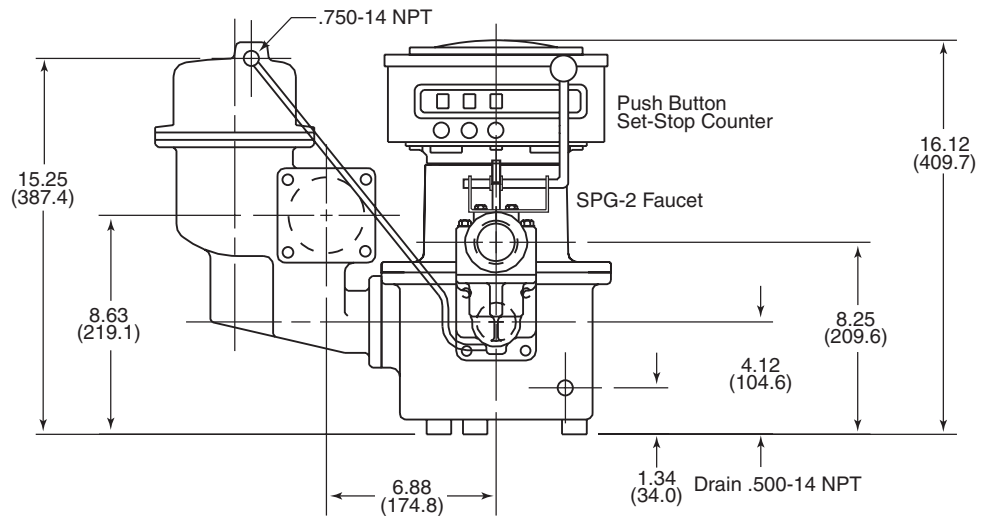

**Revisions included in SS01101L Issue/Rev. 0.3 (4/18):**

New company branding.

The specifications contained herein are subject to change without notice and any user of said specifications should verify from the manufacturer that the specifications are currently in effect. Otherwise, the manufacturer assumes no responsibility for the use of specifications which may have been changed and are no longer in effect.