

Smith Meter™ Calibrators

The displacement volume of a measuring element is a nominal value because true displacement varies with viscosity, accessory load, meter wear, and manufacturing tolerances. Volume per meter output shaft revolution through the gear train ratio then is also a nominal value.

The calibrator provides changes in the drive ratio between the meter gear train and meter driven accessories. This provides a means of manually adjusting meter registration to agree with actual gross volume displaced by the measuring element under particular operating conditions. When actuated by a thermal system, the calibrator produces changes in the drive ratio due to changes in the temperature of the liquid being metered, providing registration based on the net volume displaced by the measuring element. See Bulletins SS01038 and SS01040 for Temperature Compensation Systems.

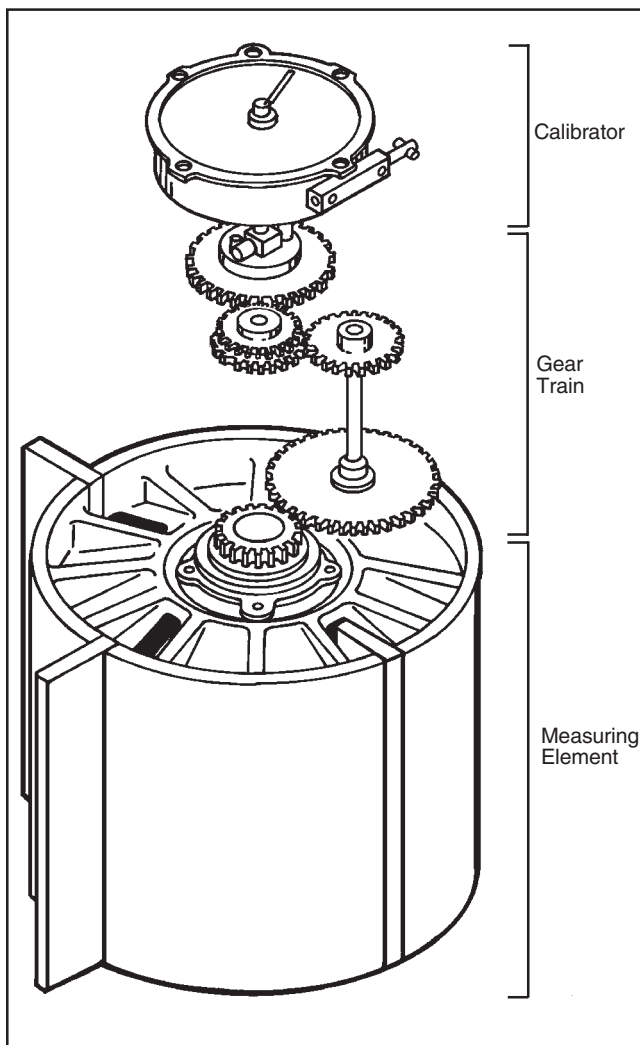

The calibrator utilizes two overriding clutches and an eccentric. By adjusting the amount of eccentricity, the calibrator can be made to vary the drive ratio between the meter gear train and the register by a maximum total of 11%. When there is no eccentricity, one revolution of the calibrator input shaft provides one revolution of the output shaft. With the maximum amount of eccentricity, one revolution of the input shaft provides 1.11 revolutions of the output shaft.

The eccentric arm is pivoted by a pin in the calibrator case. The adjustment screw (in manual calibrators) or plunger (in ATC calibrators), positions the eccentric arm to impart a degree of eccentricity between its center and the center of the calibrator case. The magnitude of eccentricity determines the magnitude of calibrator correction.

The magnitude of calibrator correction is about 4 or 5% or most gross registering meters. Approximately 8 or 9% of the total 11% is used with ATC calibrators for net registration. Each index or notch of the manually-controlled dial on gross registering meters provides an adjustment increment of .0005 (1/20th of 1%). The dial is marked +/- . Rotation in the positive (+) direction will decrease registration and in the negative (-) direction, it will increase registration. Six threads exposed on the adjustment screw is a good starting point to begin calibration with new calibrators and a 96% geared meter. On meters with Automatic Temperature Compensation, each notch provides a change equal to the Coefficient of Expansion per degree F. For example, an ATC calibrator for 38° API would provide .00046 per notch as 38° API has a Coefficient of Expansion of .00046/°F.

When the center of the eccentric arm and the center of the calibrator case coincide, the crank arm with sliding blocks, center disk, cam disk with clutches, and outer ring all revolve precisely together. Revolutions of the cam disk (calibrator input shaft) are equal to the number of revolutions of outer ring (calibrator output shaft).

When there is eccentricity between the center of the eccentric arm and the center of the calibrator case, the crank arm revolves about the center of the eccentric arm; whereas, the center disk, cam disk, and outer ring revolve about the center of the calibrator case. The parts still revolve together, but their relative positions and speeds change during a revolution. With relation to the cam disk (input shaft), the center disk advances during half of a revolution and the outer ring (output shaft) advances during the other half of that revolution.

Blocks A and B slide in the grooves of the Crank Arm and describe circles defined by the pins in the center disk and the outer ring. The circles described by the sliding blocks

have varying radii as the crank arm revolves about a center eccentric to the common center of the center disk and outer ring. Due to the varying radius, the peripheral speed of a sliding block accelerates and decelerates during a revolution.

When Sliding Block A accelerates, Sliding Block B would decelerate if it were not for the three clutches between the center disk and cam disk which prevent deceleration. This clutching action makes Sliding Block B a stationary pivot point for the crank arm, and the acceleration of Sliding Block A advances the outer ring.

When Sliding Block B accelerates, the reverse is true. Sliding Block A cannot decelerate the outer ring due to

the three clutches between cam disk and outer ring. Sliding Block A becomes a pivot point for the advancement of the center disk by Sliding Block B. Advancement of the center disk provides an advanced pivot point for the subsequent advancement of the outer ring during the next revolution.

Maintenance

Meter Calibrator

The meter calibrator requires lubrication with light oil (SAE-10). Initially, apply it after approximately five hours of operation and then about twice yearly.

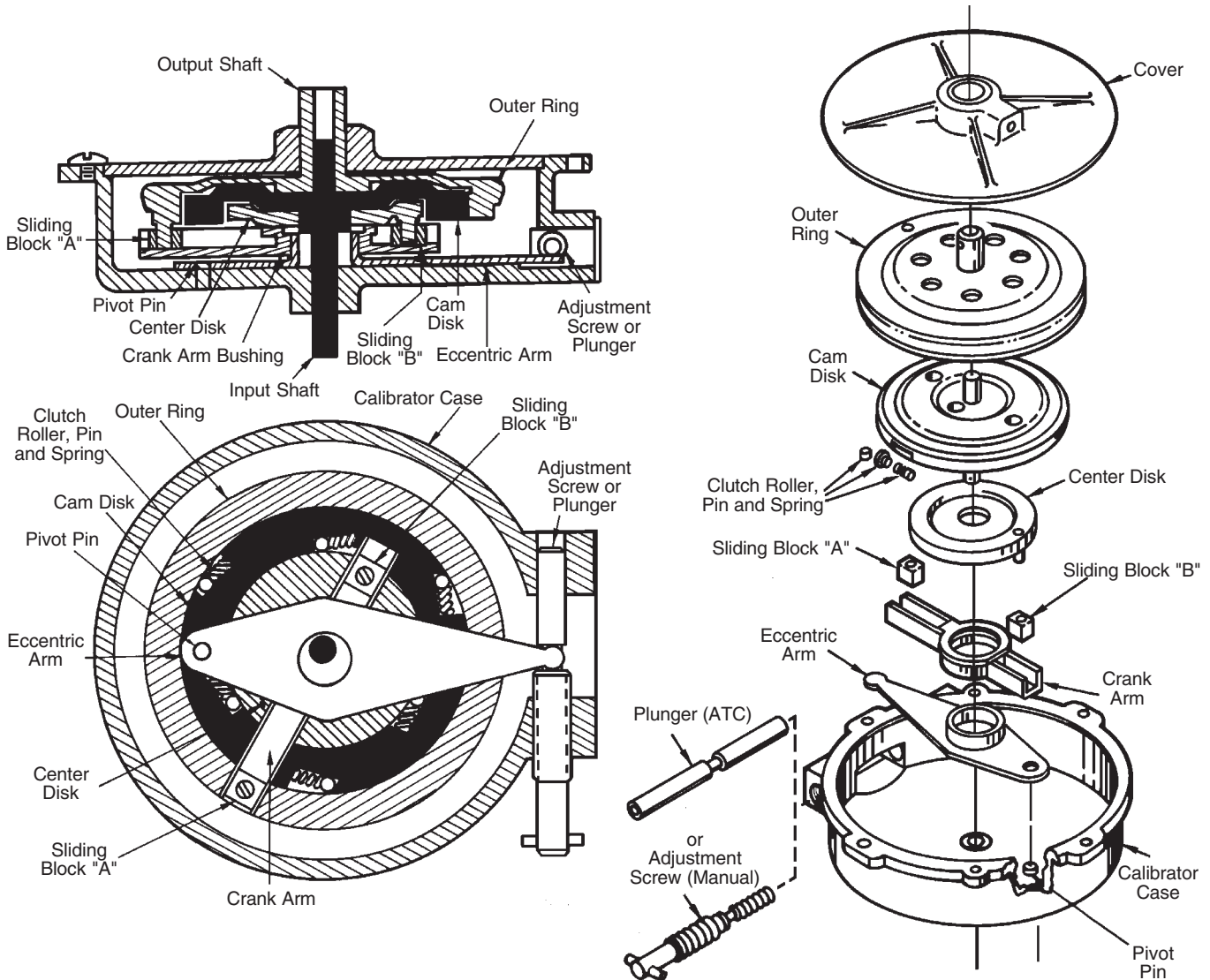

The specifications contained herein are subject to change without notice and any user of said specifications should verify from the manufacturer that the specifications are currently in effect. Otherwise, the manufacturer assumes no responsibility for the use of specifications which may have been changed and are no longer in effect.

Headquarters:

1803 Gears Road, Houston, TX 77067 USA, Phone: 281/260-2190, Fax: 281/260-2191

Gas Measurement Products:

Houston, TX USA Phone 281/260-2190
 Thetford, England Phone (44) 1842-82-2900
 Kongsberg, Norway Phone (47) 32/286-700
 Buenos Aires, Argentina Phone 54 (11) 4312-4736

Integrated Measurement Systems:

Corpus Christi, TX USA Phone 361/289-3400
 Kongsberg, Norway Phone (47) 32/286-700
 San Juan, Puerto Rico Phone 787/274-3760
 United Arab Emirates, Dubai Phone 971 +4/331-3646

Liquid Measurement Products:

Erie, PA USA Phone 814/898-5000
 Los Angeles, CA USA Phone 661/702-8660
 Slough, England Phone (44) 1753-57-1515
 Ellerbek, Germany Phone (49) 4101-3040
 Barcelona, Spain Phone (34) 93/201-0989
 Moscow, Russia Phone (7) 495/564-8705
 Melbourne, Australia Phone (61) 3/9807-2818

Beijing, China Phone (86) 10/6500-2251
 Singapore Phone (65) 6861-3011
 Chennai, India Phone (91) 44/450-4400

Visit our website at www.fmctechnologies.com