

Fittings and tubing not called out. Customer should purchase locally or consult factory.
 Refer to Form No. P1003.* for the Electronic Controller used with the Model 210 Valve.

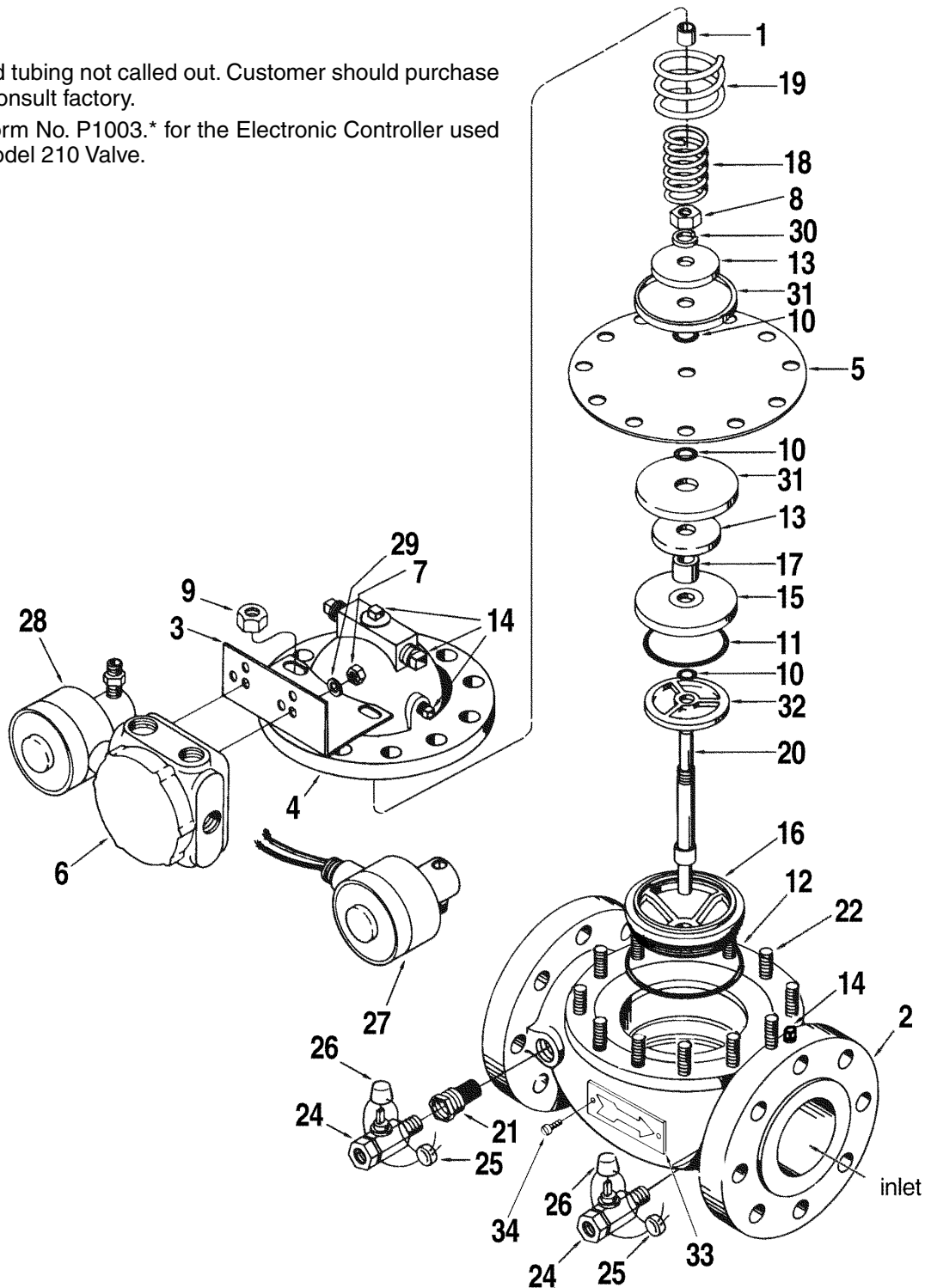

*The latest edition is indicated by a 2-digit postscript (e.g., .01, .02, etc.)

Item	Description	Qty.	Part Number
1	Bearing:		
	Bronze	1	640688-021
	Stainless Steel Ni-Resist	1	526389-007
2	Body:		
	Steel, 150#	1	528705-001
	Steel, 300#	1	528801-001
3	Bracket:		
	Solenoids with Junction Box	1	528452-001
	Required with Optional Pilots	1	528453-001
4	Cover:		
	Steel – Standard	1	528765-004
5	+ Diaphragm:		
	Buna-N	1	507400-001
	Low Swell Buna	1	507400-009
	Viton	1	507400-002
6	Junction Box	1	528497-002
7	Nut, 5/16"-18, UNC-2B	2	002876-400
8	Nut, Stem, 7/8"-14, UNF-2B	1	643756-403
9	Nut, Stud:		
	5/8"-11, UNC-2B - Standard	12	642138-405
10	+ O-Ring, Diaphragm:		
	Buna-N	3	640887-009
	Viton	3	640798-420
11	+ O-Ring, Retainer:		
	Low Swell Buna	1	507573-008
	Viton	1	507573-003
12	+ O-Ring, Seat:		
	Buna-N	1	641136-403
	Viton	1	643313-401
13	Plate, Backup:		
	Standard	2	528847-001
14	Plug, Pipe:		
	1/8" NPT, Hex. Head	3	644522-401
	3/4" NPT	5	006878-002
	1/2" NPT	2	006505-002
15	Retainer, O-Ring:		
	Ductile Iron – Standard	1	524174-004
16	@2 Seat:		
	Stainless Steel with Ni-Resist Bearing	1	528380-101
17	Spacer:		
	Steel – Standard	1	528845-001
18	Spring	1	525355-001
19	Spring, Dropover	1	529466-001
20	Stem	1	528844-001
21	Strainer, Model 09SC	1	528342-002
22	Stud: 5/8 – 11 X 2 1/4	10	643823-422
23	Bracket Mount: 5/8 – 11 x 3"	2	643823-423
24	Valve, Assembly, Needle, Model 13 (1/2" NPT)	2	643710-402
25	Seal, Lead, and Wire	2	001627-400
26	Shell	2	643706-401
27	@1 Valve, Solenoid, Model 30A N.C.	1	See Note
28	@1 Valve, Solenoid, Model 30B N.O.	1	See Note
29	Washer, Lock	2	002917-400
30	Washer, Lock Spring	1	643164-407

Item	Description	Qty.	Part Number
31	Washer, Diaphragm: Standard – Stainless Steel	2	528848-006
32	Washer, O-Ring: Ductile Iron – Standard.....	1	508040-003
33	Plate, Arrow.....	1	508533-001
34	Screw, 3/16" Drive	2	640813-001

+ Recommended stock.

Order quantity required.

R Indicates change since last revision.

* Not illustrated.

@1 When ordering, the following information is required:

1. Electrical Requirements.
2. Catalog Number displayed on the name plate of the solenoid,
or
3. Log Number displayed on the nameplate of the valve body.

@2 Ni-Resist bearing is pressed into cover and seat, then reamed to size.

Revisions included in P1037.08 Issue/Rev. 0.8 (11/09):
Total Revision.

The specifications contained herein are subject to change without notice and any user of said specifications should verify from the manufacturer that the specifications are currently in effect. Otherwise, the manufacturer assumes no responsibility for the use of specifications which may have been changed and are no longer in effect.

Contact information is subject to change. For the most current contact information, visit our website at www.fmctechnologies.com/measurementsolutions and click on the "Contact Us" link in the left-hand column.

Headquarters:

500 North Sam Houston Parkway West, Suite 100, Houston, TX 77067 USA, Phone: +1 (281) 260 2190, Fax: +1 (281) 260 2191

Gas Measurement Products:

Erie, PA USA +1 (814) 898 5000
Ellerbek, Germany +49 (4101) 3040
Thetford, England +44 (1842) 822900
Kongsberg, Norway +47 (32) 28 67 00
Buenos Aires, Argentina +54 (11) 4312 4736

Integrated Measurement Systems:

Corpus Christi, TX USA +1 (361) 289 3400
Kongsberg, Norway +47 (32) 28 67 00
San Juan, Puerto Rico +1 (787) 772 8100
United Arab Emirates, Dubai +971 (4) 883 0303

Liquid Measurement Products:

Erie, PA USA +1 (814) 898 5000
Los Angeles, CA USA +1 (310) 328 1236
Ellerbek, Germany +49 (4101) 3040
Slough, England +44 (1753) 571515
Barcelona, Spain +34 (93) 201 0989
Moscow, Russia +7 (495) 5648705
Melbourne, Australia +61 (3) 9807 2818

Beijing, China +86 (10) 6500 2251
Singapore +65 6861 3011
Chennai, India +91 (44) 450 4400

Visit our website at www.fmctechnologies.com/measurementsolutions