

Strainer, 3 and 4-Inch, E Type Parts List

Issue/Rev. 0.2 (3/11)

P0810.02

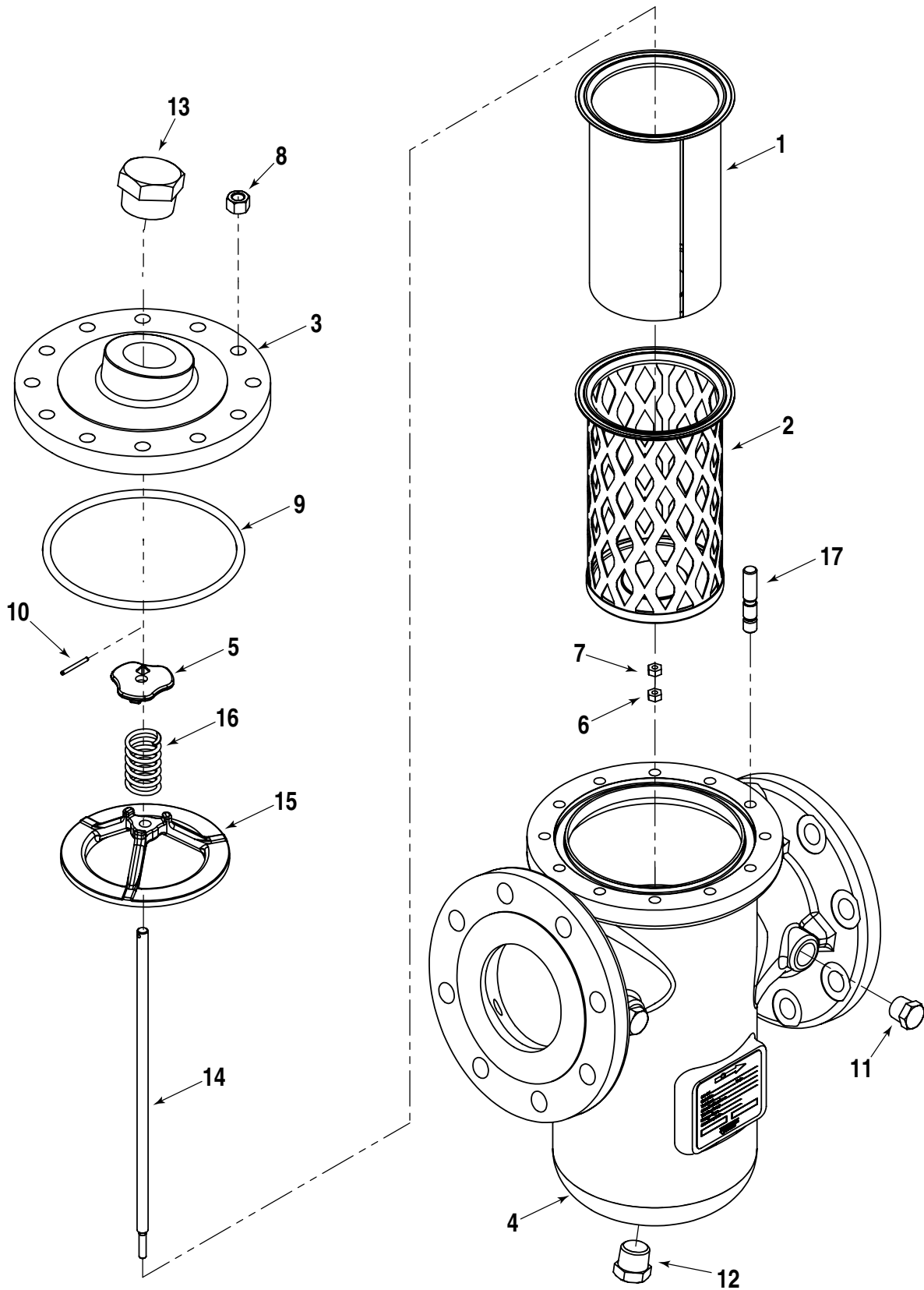

Item	Description	Qty.	Part Number
1	@1 Basket, Inner:		
	4 Mesh	1	514892-004
	10 Mesh	1	514892-010
	20 Mesh	1	514892-020
	40 Mesh	1	514892-040
	60 Mesh	1	514892-060
	80 Mesh	1	514892-080
	100 Mesh	1	514892-100
2	@1 Basket, Outer, Expanded Metal.....	1	514888-001
3	Cover, Cast Steel.....	1	577246-011
4	Housing:		
	3" Class 150 Cast Steel	1	534222-012
	4" Class 150 Cast Steel	1	534222-014
	DN 80-PN16 DIN Cast Steel.....	1	534222-011
	DN 100-PN16 DIN Cast Steel.....	1	534222-013
5	Loading Washer	1	514900-001
6	Nut, 1/4 - 20.....	1	642210-404
7	Nut, 1/4 - 20.....	1	002068-400
8	Nut, M12.....	12	670197-407
9	O-Ring:		
	Buna	1	641481-402
	Viton	1	640895-406
10	Pin	1	642434-405
11	Plug, 1/2" - 3000 lbs	2	670972-404
12	Plug, 3/4" - 3000 lbs	1	670972-401
13	Plug, 1-1/2" - 3000 lbs.....	1	670972-406
14	Rod.....	1	514899-001
15	Spider	1	514901-001
16	Spring, Compression.....	1	514902-002
17	Stud, M12 x 35	12	670019-451

* Not illustrated.

@1 If utilizing the 6/10/40 triple basket, replacement baskets will consist of the standard 40 mesh inner basket (514892-040) in addition to the following:

6 mesh outer basket.....	514888-003
10 mesh special liner.....	553441-002

Revisions included in P0810.02 Issue/Rev. 0.2 (3/11):

Limited distribution removed - 2/24/2011.

Total Revision.

Editorial Change - March 2011 - Changed title from E Series to E Type.

The specifications contained herein are subject to change without notice and any user of said specifications should verify from the manufacturer that the specifications are currently in effect. Otherwise, the manufacturer assumes no responsibility for the use of specifications which may have been changed and are no longer in effect.

Contact information is subject to change. For the most current contact information, visit our website at www.fmctechnologies.com/measurementolutions and click on the "Contact Us" link in the left-hand column.

Headquarters:

500 North Sam Houston Parkway West, Suite 100, Houston, TX 77067 USA, Phone: +1 (281) 260 2190, Fax: +1 (281) 260 2191

Measurement Products and Equipment:

Erie, PA USA +1 (814) 898 5000

Ellerbek, Germany +49 (4101) 3040

Barcelona, Spain +34 (93) 201 0989

Beijing, China +86 (10) 6500 2251

Buenos Aires, Argentina +54 (11) 4312 4736

Burnham, England +44 (1628) 603205

Dubai, United Arab Emirates +971 (4) 883 0303

Los Angeles, CA USA +1 (310) 328 1236

Melbourne, Australia +61 (3) 9807 2818

Moscow, Russia +7 (495) 5648705

Singapore, +65 6861 3011

Thetford, England +44 (1842) 822900

Integrated Measurement Systems:

Corpus Christi, TX USA +1 (361) 289 3400

Kongsberg, Norway +47 (32) 286700

Dubai, United Arab Emirates +971 (4) 883 0303

Visit our website at www.fmctechnologies.com/measurementolutions