

# Inner Mechanism

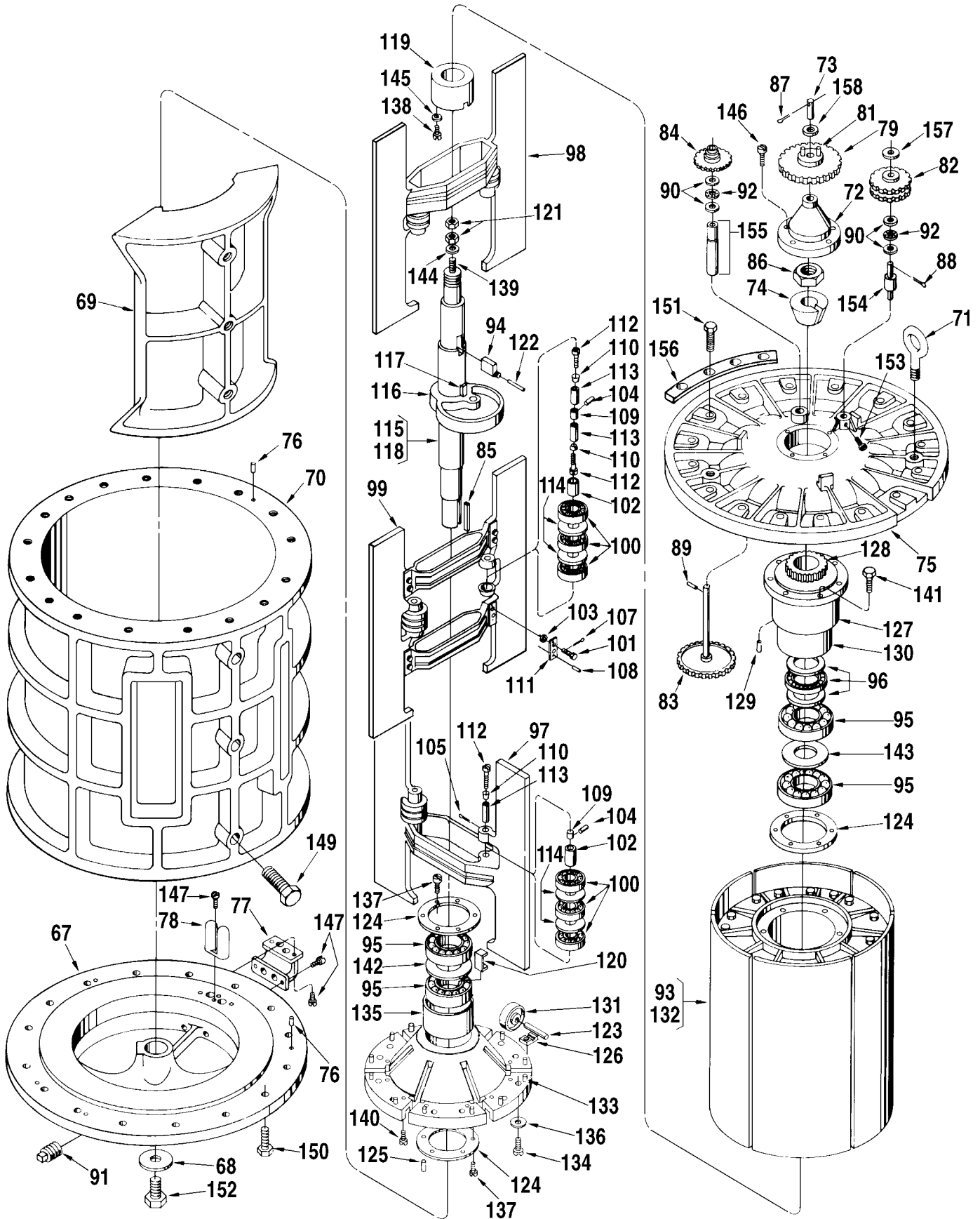

Item	Description	Qty.	M16-S1	M16-S3, S5	M16-S6
1	Adapter:				
	Standard.....	1	518350-001	518350-001	518350-001
	Slotted (For Use With Packing Gland Lubrication Kit) .....	1	518350-002	518350-002	.....
2	+ Calibrator:				
	Standard (Manual) .....	1	512059-001	512059-001	512059-001
	Temperature Compensated, Standard .....	1	512060-001	512060-001	512060-001
@1	Temperature Compensated, Special				
R	Temp. or API Gravity.....	1	516130-xxx	516130-xxx	516130-xxx
	Dummy Calibrator .....	1	516105-001	516105-001	516105-001
3	Clamp, Oil Tube.....	1	003905-001	003905-001	003905-001
4	Coupling, Drive:				
	Standard, Used on 3/16" Shaft.....	1	005969-001	005969-001	005969-001
	Used on Transmitters With 1/4" Shaft.....	1	005969-003	005969-003	005969-003
5	Pin .....	1	003540-001	003540-001	003540-001
6	Coupling, Drive .....	1	072103-001	072103-001	072103-001
7	Cover .....	1	502890-001	505231-001	513728-001
8	Cover, Knob .....	1	003553-001	003553-001	003553-001
9	Flange, Temperature Well .....	1	012026-001	012026-001	012026-001
10	+ Gasket, Cover Plate .....	1	003834-001	003834-001	003834-001
11	+ Gasket, Packing Gland .....	1	011337-001	012009-001	.....
12	Gasket, Steel .....	1	060341-001	060341-001	060341-001
13	@2+ Gland, Packing.....	1	009652-001	070318-001	515849-001
14	Housing Assembly, Outer:				
	S5 Only .....	1	.....	505239-001	.....
	All Others .....	1	502948-001	519233-001	513526-001
15	Bolt, Nozzle Mounting:				
	3/4-10 x 2-1/2".....	32	641068-406	.....	.....
	3/4-10 x 3".....	8	641068-403	.....	.....
	7/8-9 x 2-3/4".....	32	.....	640400-001	.....
	7/8-9 x 3".....	4	.....	640400-002	.....
	7/8-9 x 2-1/4".....	4	.....	640400-003	.....
	1-8 x 3-1/2".....	34	.....	.....	641178-400
16	Cap, Pipe.....	1	640259-001	640259-001	640259-001
17	Gasket, Nozzle .....	2	502935-001	502935-001	.....
18	Nipple, Pipe .....	1	640475-003	640475-003	640475-003
19	Nozzle, Inlet:				
	S5 Only .....	1	.....	505237-002	.....
	All Others .....	1	515194-002	518965-002	513529-002
20	Nozzle, Outlet:				
	S5 Only .....	1	.....	505237-001	.....
	All Others .....	1	515194-001	518965-001	513529-001
21	Nut, Hex Heavy, 1"-8 .....	4	640261-001	640261-001	640261-001
22	+ O-Ring:				
	S6 Only .....	26	.....	.....	640887-014
	All Others .....	32	640913-007	640888-003	.....
23	+ O-Ring .....	26	.....	.....	640887-011
24	Pin, Locating.....	2	003348-001	003348-001	003348-001
25	Plate, Shim:				
	20 Gauge x 9" x 16" .....	A/R	503030-002	503030-002	.....
	1/2" x 9" x 16".....	A/R	503030-001	503030-001	.....
	1/16 x 6-1/2" x 16".....	A/R	.....	.....	537090-001
	3/4" x 6-1/2" x 16" .....	A/R	.....	.....	537090-002
26	Plug, Pipe, 1/2" NPT.....	2	006105-002	006105-002	006105-002
27	Screw, Cap, 1-8 x 4-1/2" .....	4	640208-012	640208-012	640208-012

Item	Description	Qty.	M16-S1	M16-S3, S5	M16-S6
28	Strip, Filler:				
	1/2" x 6" .....	2	.....	.....	537091-003
	7/8" x 15" .....	1	.....	.....	537091-002
	1-1/8" x 15" .....	2	.....	.....	537091-001
29	Washer:				
	S6 Only .....	26	.....	.....	535492-001
	S6 Only .....	8	.....	.....	535493-001
	S5 Only .....	40	.....	643127-406	.....
	S1 and S3 Only .....	40	642495-407	640219-003	.....
30	Lubrication Assembly .....	1	513127-001	513127-001	513127-001
31	Nut, Hex .....	64	640976-402	642148-410	642148-411
32	+ O-Ring .....	2	.....	.....	640887-011
33	+ O-Ring .....	2	640888-004	640888-004	640887-014
34	+ O-Ring, Cover:				
	Buna-N .....	1	502929-001	502929-001	513740-001
	Viton .....	1	502929-002	502929-002	513740-002
35	+ O-Ring, Packing Gland .....	1	.....	.....	640888-001
36	Oiler, Gits #1230 .....	1	006588-001	006588-001	006588-001
37	Pin, Drive, 5/64" x 1/2" .....	1	006053-002	006053-002	006053-002
38	Plate, Caution .....	1	006571-001	006571-001	006571-001
39	Plate, Cover .....	1	003440-001	003440-001	003440-001
40	Plug, Pipe, 1/2" NPT .....	1	006505-002	006505-002	006505-002
41	Plug, Pipe, 3/4" NPT .....	1	006878-002	006878-002	006878-002
42	Plug, Temperature Well .....	1	012025-001	012025-001	012025-001
43	Screw, Type U x 1/8" .....	8	009880-400	009880-400	009880-400
44	Screw, #6-32 x 5/16" .....	2	006048-002	006048-002	006048-002
45	Screw, Base Plate, #10-32 x 5/8" .....	2	008338-400	008338-400	008338-400
46	Screw, Calibrator Mounting, #10-24 x 3/4" .....	2	006481-003	006481-003	006481-003
47	Screw, Cap, 5/16-18 x 3/4" .....	4	006409-002	006409-002	006409-002
48	Screw, Cap, Adapter Cover, 5/16-18 x 1-1/2", Drilled .....	2	642043-432	642043-432	642043-432
49	Screw, Cap, Nozzle:				
	1-8 x 4-1/2" .....	2	640208-012	.....	.....
	1-8 x 5" .....	2	.....	640208-013	.....
	1-8 x 6" .....	2	.....	.....	642226-405
50	Screw, Cap, Packing Gland:				
	S1 Only, 5/16-18 x 1-1/4" .....	3	006511-002	.....	.....
	All Others, 7/16-14 x 1-1/2" .....	4	.....	006410-002	006410-002
51	Screw, Cover Plate, #10-32 x 3/8" .....	2	006045-002	006045-002	006045-002
52	+ Seal, Lead, and Wire .....	2	001627-400	001627-400	001627-400
53	Shaft Assembly, Calibrator Drive .....	1	502925-001	514294-001	513739-001
54	Coupling, Lower Drive .....	1	503408-001	503408-001	503408-001
55	Coupling, Upper Drive .....	1	501970-001	501970-001	501801-002
56	Pin, Groove, 5/64 x 1/2" .....	2	006053-002	006053-002	006053-002
57	Shaft .....	1	502924-001	514295-001	513510-001
58	Stem Assembly, Adjusting .....	1	009838-001	009838-001	009838-001
59	Ball .....	2	006427-001	006427-001	006427-001
60	Plate, Base .....	1	003552-001	003552-001	003552-001
61	Plate, Retainer .....	1	003556-001	003556-001	003556-001
62	Spring, Knob .....	2	003557-001	003557-001	003557-001
63	Stem, Adjusting .....	1	003551-001	003551-001	003551-001
64	Stud:				
	1-1/4-8 x 8-1/2" .....	32	640221-001	.....	.....
	1-1/2-8 x 9" .....	32	.....	640060-002	.....
	1-3/4-8 x 14" .....	32	.....	.....	641177-401
65	Tube, Oil .....	1	514658-001	514658-001	514658-001
66	Washer .....	2	640219-002	640219-002	535492-001

Item	Inner Mechanism Description	Qty.	Part Number
67	Base.....	1	502816-001
68	Base, Shaft Cover.....	1	502832-001
69	Block.....	1	502818-001
70	Body.....	1	502836-001
71	Bolt, Eye.....	2	065433-005
72	Cap, Adjusting Screw.....	1	502833-001
73	Shaft, Drive Gear.....	1	503407-001
74	Cone, Shaft.....	1	502874-001
75	Cover, Inner: M16-S6 Inner Mech. Only.....	1	513527-001
	All Others.....	1	502817-001
76	Dowel, Cover, and Base.....	2	003348-001
77	Elbow, Pitot Fitting.....	1	503580-001
78	Fitting, Pitot.....	1	503582-001
79	+ Gear, Calibrator Drive: 1:1 Barrel.....	1	502913-001
	1:1 Hectolitre.....	1	539324-001
80	Bushing.....	1	065311-001
81	Pin.....	2	500418-001
82	+ Gear, Idler: 1:1 Barrel.....	1	502910-001
	1:1 Hectolitre.....	1	539322-001
83	+ Gear, Jackshaft.....	1	502905-001
84	+ Gear, Single.....	1	502908-001
85	Key, Rotor Shaft.....	1	502937-001
86	Nut, Rotor Shaft.....	1	502954-001
87	Pin, Cotter, 1/16 x 1/2".....	1	001095-401
88	Pin, Cotter, 1/8 x 3/4".....	1	001292-401
89	Pin, Groove, 1/8 x 3/4".....	1	006127-002
90	+ Plate, Thrust Bearing.....	4	001111-001
91	Plug, Pipe, 1" NPT.....	1	006482-002
92	+ Retainer and Balls, Thrust Bearing.....	2	070360-001
93	Rotor Assembly (Standard Only).....	1	515694-001
94	Bar, Adjusting.....	1	502919-001
95	+ Bearing, Rotor.....	4	502938-001
96	+ Bearing, Thrust: Standard.....	1	640207-001
	All Iron.....	1	640207-499
97	R@3 Blade Assembly, Lower: Standard.....	1	550566-001
	All Iron.....	1	551554-001
98	R@3 Blade Assembly, Upper: Standard.....	1	550565-001
	All Iron.....	1	551553-001
99	R@3 Blade Assembly, Middle: Standard.....	1	550564-001
	All Iron.....	1	551552-001
100	R+ Bearing.....	6	640163-090
101	Bolt.....	8	503458-001
102	Bushing.....	2	503915-001
103	Nut, Hex, 1/2-20 x 9/16".....	8	640266-001
104	Pin, Blade Bearing Bushing.....	2	503919-001
105	Pin, Cotter, 1/8 x 2".....	2	006187-001
107	Pin, Cotter, 3/32 x 7/8".....	8	003240-400
108	Pin, Dowel.....	8	502884-001
109	Plug, Center.....	2	503916-001
110	Plug, End.....	4	513018-001

Item	Description	Qty.	Part Number
111	Retainer, Dowel .....	8	503409-001
112	Screw, Cap: Current Design, 1/4-28 x 2-1/4" .....	4	640438-402
	Previous Design, 1/4-28 x 1-3/4" .....	4	640438-001
113	Sleeve, Expansion: Current Design, 2-1/4" Long .....	4	503917-002
	Previous Design, 1-3/4" Long .....	4	503917-001
114	Washer, Spacer .....	1	504272-001
115	Cam and Shaft Assembly .....	1	502934-001
116	Cam .....	1	518068-001
117	Key .....	1	502937-001
118	Shaft .....	1	502838-001
119	Collar .....	1	502875-001
120	+ Lock, Rotor Bearing .....	2	502928-001
121	Nut, Adjusting Screw .....	2	006705-002
122	Pin, Adjusting Bar .....	1	640200-018
123	Pin, Rotor Cover Roller .....	6	503551-001
124	Plate Assembly, Lock .....	3	503651-001
125	Pin .....	1	503321-001
126	Plate, Rotor Cover Roller Pin .....	12	502858-001
127	Plate, Rotor Gear .....	1	502835-001
128	Gear, Rotor .....	1	502851-001
129	Pin, Lock .....	1	503321-001
130	Sleeve, Upper Rotor Bearing .....	1	502944-001
131	+ Roller, Rotor Cover .....	6	503552-001
132	Rotor, Sub Assembly .....	1	502933-001
133	Dowel .....	13	502945-001
134	Screw, 5/8-11 x 2-1/4", Drilled .....	12	503665-001
135	Sleeve, Lower Rotor Bearing .....	1	502944-001
136	Washer, Flat .....	12	640437-001
137	Screw, 3/8-16 x 7/8" .....	18	006415-002
138	Screw, #10-32 x 3/8" .....	2	643339-401
139	Screw, Adjusting .....	1	502920-001
140	Screw, Pin Clamp, 3/8-16 x 1-1/4" .....	12	660248-404
141	Screw, Rotor Gear Plate, 1/2-13 x 1-3/4", Drilled .....	6	503664-001
142	Spacer, Lower Rotor Bearing .....	1	504274-001
143	Spacer, Upper Rotor Bearing .....	1	504273-001
144	Washer, Flat .....	1	641837-402
145	Washer, Flat .....	2	006929-001
146	Screw, 3/8-16 x 1-1/4" .....	4	002238-401
147	Screw, 5/16-18 x 1" .....	4	060133-002
148	Screw, 5/16-18 x 3/4" .....	2	009548-400
149	Screw, Body, and Block, 5/8-11 x 2-1/4" .....	4	503665-001
150	Screw, Cover, and Base, 3/4-10 x 2-3/4" .....	16	641068-402
151	Screw, Cover: M16-S6 Inner Mech. Only, 3/4-10 x 3-3/4" .....	16	641068-404
	All Others, 3/4-10 x 2-3/4" .....	16	641068-402
152	Screw, Rotor Shaft .....	1	643535-401
153	Screw, Set, 1/4-20 x 1/4" .....	1	006538-001
154	Shaft, Pinion With Spacer .....	1	502930-001
155	Sleeve Assembly, Jackshaft .....	1	502831-001
156	Support Ring, M16-S6 Inner Mech. Only .....	4	535484-001
157	Washer, Flat .....	1	005500-401
158	Washer, Flat .....	1	060554-001
159	Washer, Lock .....	2	642482-407

Item	Description	Qty.	Part Number
<b>Inner Mechanism General Assembly Numbers</b>			
	M16-S1, S3, and S5 Barrel Geared, Standard .....		550604-091
	M16-S6 Barrel Geared, Standard .....		551017-091
	M16-S1, S3, and S5 Barrel Geared, All Iron Trim .....		550604-092
	M16-S6 Barrel Geared, All Iron Trim .....		551017-092
	M16-S1, S3, and S5 Hectolitre Geared, Standard.....		550604-891
	M16-S1, S3, and S5 Hectolitre Geared, All Iron Trim .....		550604-892

For other variations or special clearances, consult Smith Parts Operation.

+ Recommended stock.

R Indicates change since last revision.

A/R As required.

@1 Note 1: When ordering, include product temperature range, specific or API Gravity, API Table used, and meter and gearing the calibrator is to be used in conjunction with.

@2 Note 2: See Form No. P0605.\* for component parts.

@3 Note 3: When replacing blades in meters manufactured prior to and including December 1982 (Date Code BM), all three blades must be replaced together (upper, middle, lower). Current design features the lightening holes. Once complete, blades can be replaced independently. When replacing blades in meters manufactured during or after January 1983 (Date Code CA), use the **current design** part number.

\* The latest edition is indicated by a 2-digit postscript (e.g., .01, .02, etc.).

The specifications contained herein are subject to change without notice and any user of said specifications should verify from the manufacturer that the specifications are currently in effect. Otherwise, the manufacturer assumes no responsibility for the use of specifications which may have been changed and are no longer in effect.

Contact information is subject to change. For the most current contact information, visit our website at [www.fmctechnologies.com/measurementsolutions](http://www.fmctechnologies.com/measurementsolutions) and click on the "Contact Us" link in the left-hand column.

---

**Headquarters:**

500 North Sam Houston Parkway West, Suite 100, Houston, TX 77067 USA, Phone: +1 (281) 260 2190, Fax: +1 (281) 260 2191

**Measurement Products and Equipment:**

**Erie, PA USA** +1 (814) 898 5000

**Ellerbek, Germany** +49 (4101) 3040

**Barcelona, Spain** +34 (93) 201 0989

**Beijing, China** +86 (10) 6500 2251

**Buenos Aires, Argentina** +54 (11) 4312 4736

**Burnham, England** +44 (1628) 603205

**Dubai, United Arab Emirates** +971 (4) 883 0303

**Los Angeles, CA USA** +1 (310) 328 1236

**Melbourne, Australia** +61 (3) 9807 2818

**Moscow, Russia** +7 (495) 5648705

**Singapore,** +65 6861 3011

**Thetford, England** +44 (1842) 822900

**Integrated Measurement Systems:**

**Corpus Christi, TX USA** +1 (361) 289 3400

**Kongsberg, Norway** +47 (32) 286700

**Dubai, United Arab Emirates** +971 (4) 883 0303

**Visit our website at [www.fmctechnologies.com/measurementsolutions](http://www.fmctechnologies.com/measurementsolutions)**