

#### Operating Instructions

1. Depressurize the meter tube.
2. Loosen the clamping bar (1) bolts, then slide the clamping bar out.
3. Pull the carrier assembly (2) straight out, attached is the orifice plate carrier, seal ring, and orifice plate (3).
4. To inspect the orifice plate, push the orifice plate and seal ring out from the back of the orifice plate carrier.

#### To Replace the Orifice Plate

1. Insert the orifice plate with the sharp square edge of the bore facing upstream into the carrier (3) followed by the seal ring, make sure that the O-Ring seals and the retainer O-Ring are in good condition. Also, check the sealing bar O-Ring seal. Apply a light coating of a petroleum-based lubricant to the entire surface of the O-Rings prior to re-assembly.
2. Insert the carrier assembly (2) with the orifice plate and seal ring in place into fitting body until it seats. Make sure to line up the dowel pin (4) in the sealing bar with the dowel hole in the body (5).



**OrificeMaster Single Chamber Orifice Fitting**

3. Slide in the clamping bar (1) and tighten bolts assuring that contact of sealing bar (2) to body (5) is metal to metal.
4. Pressurize the line and return to service.

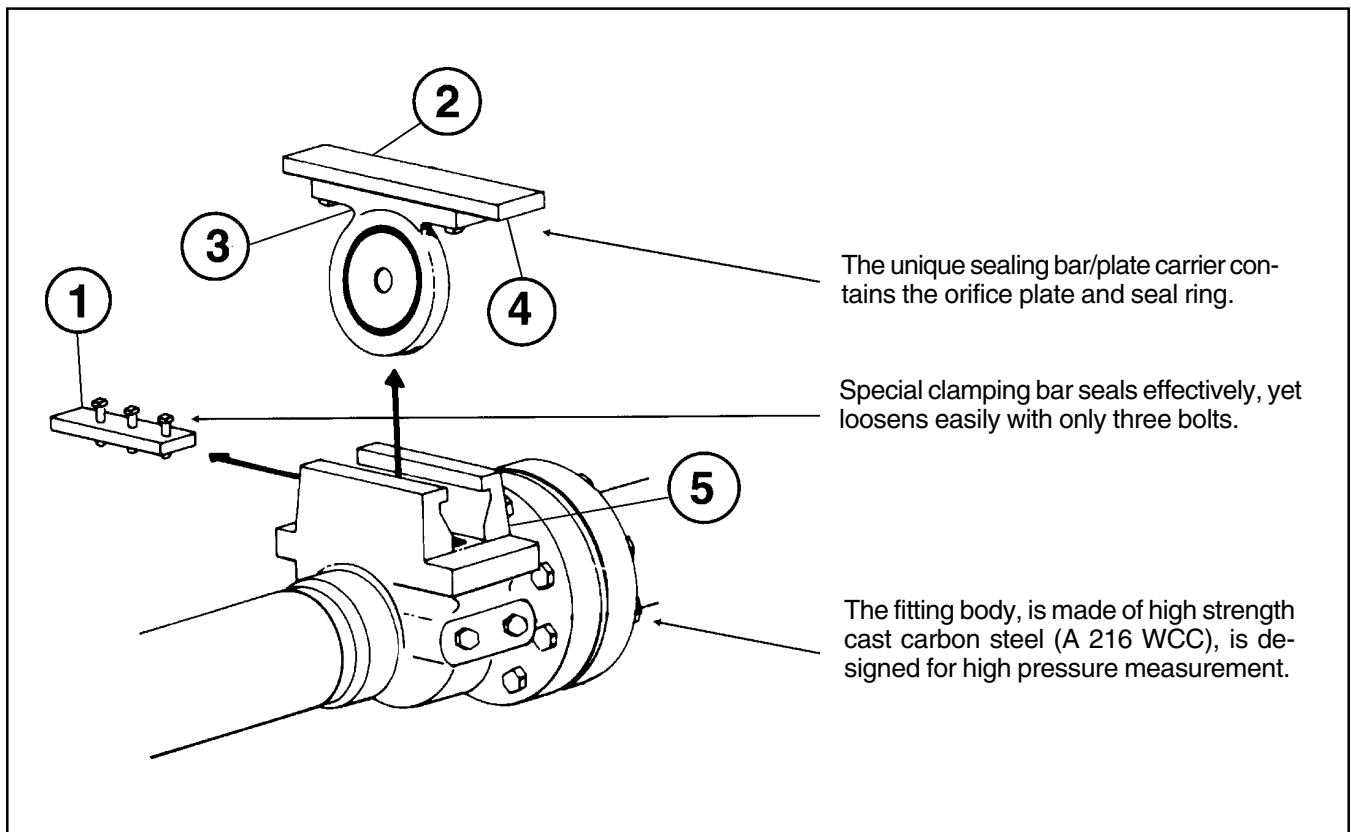

Revisions included in MNOR003 Issue/Rev. 0.1 (2/06):  
Page 1: Revised removing and replacing orifice plate instructions.

The specifications contained herein are subject to change without notice and any user of said specifications should verify from the manufacturer that the specifications are currently in effect. Otherwise, the manufacturer assumes no responsibility for the use of specifications which may have been changed and are no longer in effect.

---

**Headquarters:**

1803 Gears Road, Houston, TX 77067 USA, Phone: 281/260-2190, Fax: 281/260-2191

**Gas Measurement Products:**

**Erie, PA USA** Phone 814/898-5000  
**Thetford, England** Phone (44) 1842-82-2900  
**Kongsberg, Norway** Phone (47) 32/286-700  
**Buenos Aires, Argentina** Phone 54 (11) 4312-4736

**Integrated Measurement Systems:**

**Corpus Christi, TX USA** Phone 361/289-3400  
**Kongsberg, Norway** Phone (47) 32/286-700  
**San Juan, Puerto Rico** Phone 787/274-3760  
**United Arab Emirates, Dubai** Phone 971 +4/331-3646

**Liquid Measurement Products:**

**Erie, PA USA** Phone 814/898-5000  
**Los Angeles, CA USA** Phone 661/296-7711  
**Slough, England** Phone (44) 1753-57-1515  
**Ellerbek, Germany** Phone (49) 4101-3040  
**Barcelona, Spain** Phone (34) 93/201-0989  
**Moscow, Russia** Phone (7) 095/564-8705  
**Melbourne, Australia** Phone (61) 3/9807-2818

**Beijing, China** Phone (86) 10/6500-2251  
**Singapore** Phone (65) 6861-3011  
**Chennai, India** Phone (91) 44/450-4400

**Visit our website at [www.fmcmeasurementsolutions.com](http://www.fmcmeasurementsolutions.com)**