



Contents

Introduction	Page 2
Installation	Page 4
Basic Operations	Page 4
Program Mode	Page 5
Run Mode	Page 20
Serial Communications	Page 24
Serial Commands	Page 25
I/O Terminal Description	Page 35
Wiring Diagrams	Page 37
Dimensions	Page 44

Due to the flexibility of the FloMate design, many configurations (both hardware and software) are possible. It is recommended that the entire manual be reviewed prior to installation and programming.

Caution

The default or operating values used in this manual and in the program of the FloMate are for factory testing only and should not be construed as default or operating values for your metering system. Each metering system is unique and each program parameter must be reviewed and programmed for that specific metering application.

Disclaimer

FMC Technologies Measurement Solutions, Inc. hereby disclaims any and all responsibility for damages, including but not limited to consequential damages, arising out of or related to the inputting of incorrect or improper program or default values entered in connection with the FloMate.

Introduction

The FloMate Batch Control performs three basic functions:

- Batch control with high and slow speed delivery outputs
- Totalizes flow or batch cycles
- Flow ratemeter with high and low alarm outputs

The following is a description of all of the features of the unit, broken down into each major function.

Batch Control

Operation

The batch control has six digits of display and two programmable setpoints (First Trip and Final Trip). The setpoints can be programmed to control two outputs. The outputs are actuated when a start input or start key is pressed, and deactivated when the appropriate setpoint is reached. Actual or remaining counts can be displayed for a given batch size. The Start, Stop, and Reset keys can be programmed to perform different functions on the batch control.

First Trip/Final Trip

The batch control has two setpoints that are programmable to control either Relays K1 and K2 or Output Transistors 3 and 4. First Trip is associated with Relay K1 or Transistor 3 and Final Trip is associated with Relay K2 or Transistor 4.

Auto Recycle

The batch control can be programmed to Auto Recycle. When Auto Recycle is programmed, the batch counter automatically resets to zero when the batch size setpoint is reached. A timer, with a range from 0.1 to 9.9 seconds, is set to determine the dwell time before the batch control automatically restarts. The Auto Recycle mode of operation allows overrun counts caused by time delays in relays and valves to be automatically compensated for in succeeding batches.

Scaler

The FloMate is equipped with a scaler to accept K-Factors (Kpv) from .0001 to 99999.

Count Mode

The FloMate has the capability to accept pulses from single-channel or dual-channel flow meters. Single-channel input will allow unidirectional counting only. With a dual-channel input, the pulses can be used as counting with inhibit, counting with direction, or quadrature.

Count Speed

The count input pulse speed can be digitally filtered and is selectable for different rates for the various count mode options. Please refer to the Programming Section, Submenu 55 for additional details.

Output Transistor 2

This output is programmed under the Batch Control Menu Row and can be selected to be either the Batch Overrun Setpoint output or a Quadrature Error output.

When selected as the overrun output, the output becomes enabled after counts = batch size. The overrun setpoint is set to a number larger than the expected overrun counts that would occur under normal operating conditions. Should counts continue to occur and the count value reaches the overrun setpoint, the overrun output turns on.

When programmed to provide Quadrature Error Indication, the transistor can be set to turn on for a specified time period when a quadrature error is detected.

Offset

The offset setpoint allows the batch counter to be reset to a number other than zero.

Totalizer

Operation

The totalizer can be programmed to be a ten-digit flow totalizer or a six-digit batch cycle counter. The totalizer is programmed by selecting the count source as flow or batch. The Start and Reset keys can be programmed to act on the totalizer.

Auto Stop

The totalizer has a setpoint which can be used to terminate automatic batching operations. The Auto Stop function can be disabled, in which case the totalizer counts only.

Output Transistor 1

This output is programmed under the totalizer menu and can be selected to provide a pulse-out for remote totalizing, a totalizer setpoint alarm indication, or quadrature error indication. Refer to the Programming Section, Submenu 23 for details.

Ratemeter

Operation

The ratemeter has five-digits of display and calculates flow by measuring the time interval between input pulses and then reciprocating the time. The rate multiplier is used to provide rate readings in the units of measure selected. The Stop and Reset keys can be programmed to act on the ratemeter.

Smoothing

The smoothing function allows the ratemeter to average rate readings from 1.0 seconds to 7.5 seconds in 0.5 second steps. There is no smoothing when programmed for 0.5 seconds.

Hi/Lo Outputs

The Rate Hi and Lo setpoints are used to set rate values at which the rate output alarms turn on. The Hi output is turned on if the rate is greater than the Hi setpoint, the Lo output is turned on if the rate is lower than the Lo setpoint. The outputs can be programmed to follow, time out, or latch. The Lo Rate alarm can be selected to function continuously or only during a batch (Start Enabled).

The Lo and Hi rate setpoints can control either Relays K1 and K2 or Transistors 3 and 4. The outputs are selectable under the Program Other menu row.

Lo Rate Alarm Output Delay

The LoRate output can be disabled for a time period at the start of each batch cycle. The timer can be set for 0.0 to 9.9, seconds. This feature works only if the Lo rate alarm is selected to be start enabled.

Rate at Zero

The ratemeter displays zero rate when the time interval between input pulses exceeds the programmed rate zero time. The timer can be set from 1 to 15 seconds.

Rate Display Header

The rate display header can be programmed into the unit and will be shown along with the rate value and rate setpoints on the display. The header can be up to four characters long with character choices of: A-Z, space, /, or #.

Rate 4-20 mA Output

The analog rate output range can be programmed at both the 4 mA and 20 mA points. This permits analog rate indications from 0 to full scale rate or to select a portion of the rate range. The analog output can be digitally calibrated in the Program mode.

Run Mode

In the Run mode of operation, the display is selectable to provide various pieces of information as a default mode. The setpoints can also be displayed by depressing the key associated with that particular value. This setpoint value will be displayed for five seconds after which the display reverts to the default display and updates any counts.

The setpoints are lockable so that they may not be changed by anyone not having access to the Program mode. Please refer to Program Mode Submenu 51 for additional details.

The programmed values can be protected in two ways. There is password protection which requires the operator to know the password to gain entry to the Program mode. Please refer to Program Mode Submenu 52 for further details.

There is also a program inhibit feature which allows a control input to be selected as a program inhibit input. When active, this input would prohibit any access to the Program mode.

One feature of the FloMate is that it has an RS-485 communications port. A communications link can be set up with a remote computer to access all of the programmed values as well as the run time data. This communications link may not be disabled or inhibited.

Installation

The FloMate batch controller is intended to be panel-mounted. The unit comes supplied with all the necessary mounting hardware. The panel cutout for the FloMate should be 2.65" high by 5.41" wide.

The cutout should be rectangular in shape with no radii in the corners. The panel can be up to 0.62" thick.

Installation Procedure:

1. Prepare the panel cutout.
2. Slip the O-ring over the FloMate housing from the back end and push it up to the front bezel. Make sure the O-ring is pushed into the slight depression behind the front bezel.
3. Place the FloMate through the cutout in the panel from the front side of the panel.
4. Start the hold-down screws into the hold-down clips, as indicated on the side of the clips.

5. Snap the hold-down clips into place on the sides of the FloMate. They fit into the grooves just behind the front bezel.
6. Tighten the hold-down screws until the bezel is pulled down to the front of the panel. Be careful not to over-tighten.

Wiring

The terminal blocks are removable for ease of wiring. Please refer to the wiring diagrams on Pages 35 to 43 for the proper application.

Notes:

1. Input power lines must be fuse-protected. See Wiring Diagrams, Page 37, for details.
2. Install RC circuit across the relay contacts for electrical noise suppression. See Wiring Diagrams, Page 40, for details.

Basic Operation

After installing the FloMate unit, the operator needs to enter the necessary operating parameters. All of these can be entered via the front panel. Some parameters can be entered while in the Run mode and some require the unit to be in the Program mode.

When power is first applied to the unit, it will display the message "RUN INSTALLATION". This alerts the operator that the factory default parameters are saved in the memory. Depressing the Stop key clears this message. The display will then flash the message "VERIFY PROGRAM DATA" for one second.

The operator should first enter the Programming mode and set the parameters necessary for operating the

FloMate with the specific flow meter being used. The meter K-Factor and the proper rate multiplier should be programmed.

Second, the operator should set all of the necessary operating parameters for the FloMate to work in his or her specific application (i.e., all of the setpoints and how the inputs and outputs should be configured).

When exiting the Program mode for the first time, the display flashes the message "B SIZE = ZERO" for one second. This is a reminder to set the batch size setpoint.

Program Mode

The unit must be stopped and not in Jog to enter the Program mode. All count and rate functions are inhibited when in the Program mode. The analog output goes to a value of 4 mA when the unit is being programmed and during power-up diagnostic tests.

Accessing Programming Mode

Pressing the “<” and “>” keys down at the same time causes the display to prompt the user for a password. The user has 15 seconds to enter a password before the unit displays the message “EXIT PGM ENTRY” and reverts to the Run mode. When the correct password is entered, the unit enters into the Program mode and displays the message “PROGRAM?”. The password is not displayed but an underscore is shown for each digit entered.

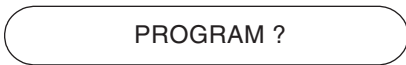

Note: The unit comes from the factory with the password of 000000. When the password is set to zeros, the unit enters the Program mode directly after pressing the “<” and “>” keys.

From the Program mode entry/exit display, access to submenu items can be obtained in two ways.

1. A. Press the “^” (up) key to scroll through the main menu items (Row X).
- B. Press the “<” or “>” key to scroll through the submenu items (Column Y).
2. From the program menu chart, identify the row (x) and column (y) of the submenu desired. Enter the XY number into the program display. Access is gained without scrolling with the arrow keys.

In some cases, submenus are “layered” (Z axis). Access is gained from the “top” layer of the submenu by pressing the appropriate front panel key. All submenus are mapped out in detail with their definitions in the pages following the program menus chart. The Help key will provide programming information when pressed at any time during programming.

To exit the programming mode: Use the “<” and “>” and “U” keys to return to the programming entry/exit display. This can also be accomplished by pressing the “<” and “>” at the same time. Then press the Reset key to exit the Programming mode and return to the Run mode of operation.

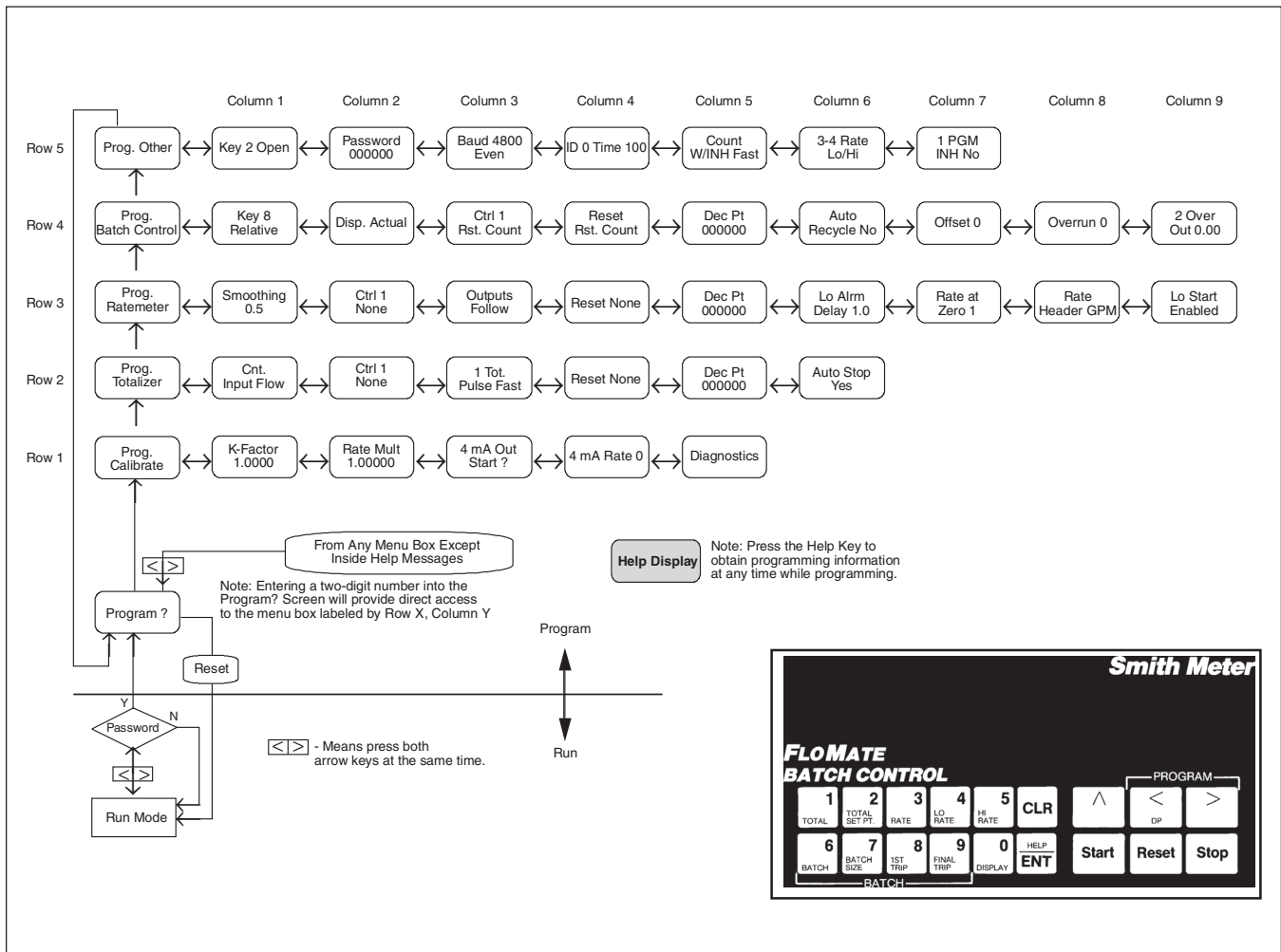

Program Mode (continued)

Factory Defaults

The following is a list of all the factory settings for the various programmable values.

Row	Column	Description
1 - Calibration	1	K-Factor = 1.0000
	2	Rate Multiplier = 1.00000
	3	-- Analog output adjust
	4	4 mA Rate = 0.00, 20 mA Rate = 7500
	5	-- Diagnostics - display/memory test
2 - Totalizer	1	CNT Input - Flow
	2	CTRL 1, 3, 4, 5 - none, 2 - Rst Count
	3	1 Tot Pulse Fast
	4	Start, Reset - None
	5	Decimal Point - 000000
	6	Auto Stop - YES
3 - Ratemeter	1	Smoothing - 0.5
	2	Control 1, 2, 3, 4, 5, - None
	3	Outputs - Follow
	4	Reset - None, Stop - Unlatch LO/Hi
	5	Decimal Point - 00000
	6	Lo Alarm Delay - 1.0
	7	Rate at Zero - 1
	8	Rate Header - GPM
	9	Lo Output - Start Enabled
4 - Batch Control	1	Key 8 - Relative
	2	Display - Actual
	3	Control 1 - Reset Count 2 - None 3 - Start 4 - Stop 5 - Jog
	4	Start - Only Start Reset - Reset Count Stop - Only Stop
	5	Decimal Point - 000000
	6	Auto Recycle - No
	7	Offset - 0
	8	Overrun - 0
	9	2 Over Out - 0.00
5 - Other	1	Key 2, 4, 5, 7, 8, 9 - Open
	2	Password - 000000
	3	Baud - 4800, Even
	4	Id - 0, Time - 100
	5	Count w/Inh Fast
	6	3-4 Rate Lo/Hi
	7	1-2-3-4-5 Program Inhibit - No

Program Mode (continued)

Program Calibrate

Submenu 11 - K Factor

K FACTOR 1.0000

Range 0.0001 to 99999

CLR key enables entry of new K-Factor.

0-9 and DP keys are used to write the number of flowmeter pulses per unit volume (Kpv) to the display.

ENT writes the new K-Factor to memory.

Kpv is the number of flowmeter pulses per whole unit of measure (mass or volume). It may be desirable to program a decimal point on the batch counters display in order to set batch sizes to the nearest tenth, hundredth, etc., of a whole unit. The control does not account for the batch counter's decimal point location. Therefore, the user must account for the decimal point when K-Factor is entered. If the batch counter is intended to count in increments of tenths of units, the K-Factor to be programmed is Kpv divided by ten; for hundredths of units, the K-Factor to be programmed is Kpv divided by 100, etc.

Submenu 12 - Rate Multiplier

RATE MULT. 1.00000

Range .00001 to 999999

CLR key enables entry of new rate multiplier.

0-9 and DP keys are used to write the rate multiplier to the display.

ENT writes the new rate multiplier to memory.

The rate multiplier is calculated by the formula:

$$R_m = \frac{\text{\# of seconds in time unit} \times \text{Rate DPF}}{\text{Count DPF}}$$

Where:

“Rm” is the rate multiplier.

“# of seconds in time unit” is 60 for a display of units per minute, 3600 for a display of units per hour, etc.

“DPF” is the decimal point factor. The count and/or rate displays may have a decimal point programmed to show better resolution than whole units of volume. Count and rate decimal points are programmed independently of each other, but must be included in the rate multiplier calculation. The following table lists the proper DPF selection:

Rate Display	Rate DPF	Count Display	Count DPF
XXXXXX	1	XXXXXX	1
XXXXX.X	10	XXXXX.X	10
XXXX.XX	100	XXXX.XX	100
XXX.XXX	1000	XXX.XXX	1000
XX.XXXX	10000	XX.XXXX	10000
X.XXXXX	100000	X.XXXXX	100000

Submenu 13 - 4-20 mA Output Calibration

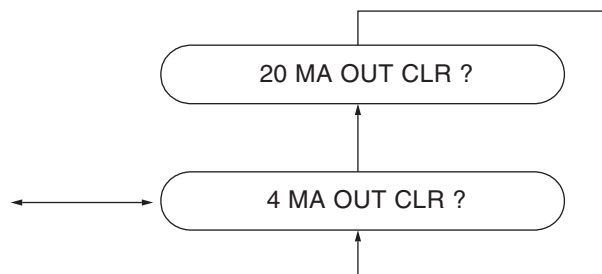

To calibrate the analog output signal, first turn off all power and then connect the analog output “+” terminal to the 15 Vdc out terminal of the control. Connect the analog output “-” terminal to a current meter and connect the other end of the current meter to the 15 Vdc ground terminal. Turn power back on and select Submenu 13. Press the “CLR” key to start the calibration process and use the left/right-arrow keys to adjust the current to 4 mA, then press the “ENT” key to enter the 4 mA calibration point. Use the up-arrow key to select the 20 mA setpoint. Press the “CLR” key to start the calibration process and use the left/right-arrow keys to adjust the current to 20 mA, then press the “ENT” key to enter the 20 mA calibration point.

Submenu 14 - Rate 4-20 mA Output Range

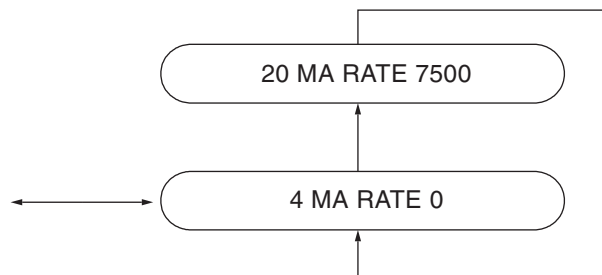

The rate output range is programmed at both the 4 mA and 20 mA points. This permits analog rate indications from 0 to full scale of the digitally-displayed rate or to select a portion of the rate range. Use the up-arrow key to select the 4 mA or 20 mA setpoints and then use the “CLR”, 0-9 and “ENT” keys to enter a rate value at each setpoint.

Program Mode (continued)

Submenu 15 - Diagnostics

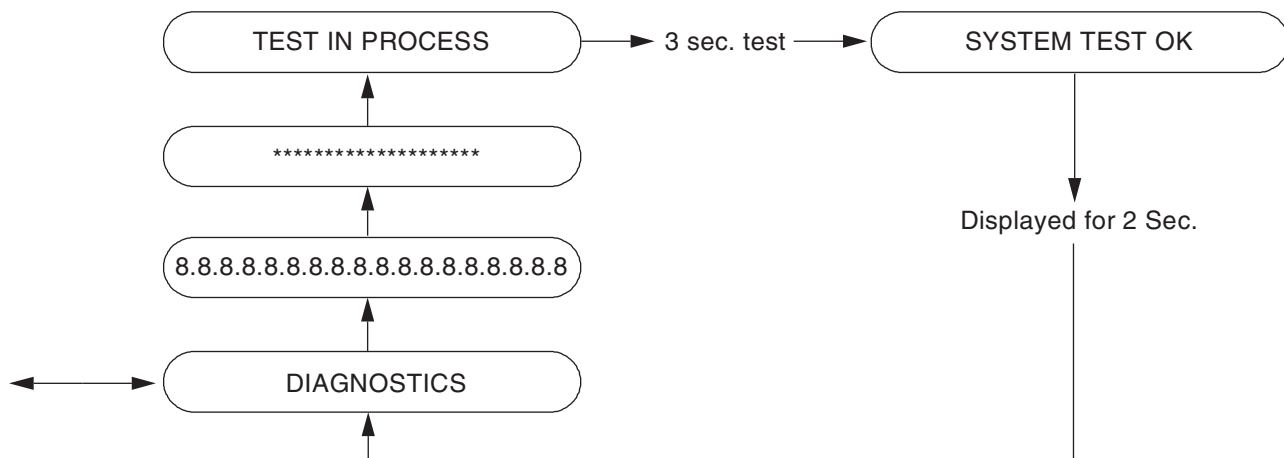

The diagnostics allow the user to test the FloMate's display and internal memory. Press the up-arrow key for Display Test 1. Each of the display's 16 characters will go to 8 with the decimal point lit. Press the up-arrow key for Display Test 2. Each character will go to "*". Press the up-arrow key for the internal memory test. The display will read "TEST IN PROCESS" for three seconds while the tests are being run. The display will read "SYSTEM TEST OK" for two seconds, then go back to "DIAGNOSTICS" if no memory errors are detected. If the unit detects a memory error, the display will hold an error message. The error messages are:

ROM ERROR

INTERNAL ERROR

EXTERNAL ERROR

These errors are non-recoverable. It is possible that electrical noise caused the diagnostic failure so the power to the unit should be cycled (turned off and then turned back on). The memory tests are always performed at power-up. If the same test fails at power-up, the unit is likely to need repair. If a different test fails, or if the unit powers up normally, it is likely that the unit is experiencing electrical noise problems. Refer to Wiring Diagrams on Page 40 for techniques for suppressing electrical noise.

Note that the error messages for the power-up memory tests may be different than the error messages for the Program mode diagnostic memory tests. The following table lists each test failure and its associated error message in each test mode.

Test Failure	Error Message	
	Program Diagnostics	Power-Up Diagnostics
ROM Checksum Error	ROM ERROR	ROM ERROR
Int. RAM Bit Error	INTERNAL ERROR	RAM ERROR
Ext. RAM Bit Error	EXTERNAL ERROR	EXT RAM ERROR
EXT. RAM Checksum Error	N/A	STORE ERROR

Note that the power-up diagnostic memory test performs an additional test, the external RAM checksum. If the calculated checksum of the external RAM (the memory which holds the user program) does not match the stored checksum, the user program has been corrupted and the message "STORE ERROR" appears on the display. This error is recoverable by pressing the Stop key. The message "VERIFY PGM DATA" then appears on the display for one second to prompt the user to locate and correct Program mode item(s) which have been altered.

Program Totalizer

Submenu 21 - Totalizer Count Input

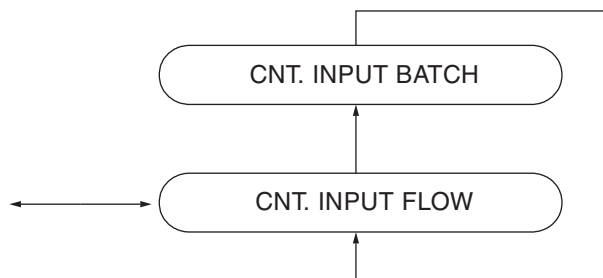

Program Mode (continued)

The totalizer can be programmed to totalize flow by setting the totalizer input source to "Flow". Selecting "Batch" as the input source causes the totalizer to count the number of times the batch counter reaches the final setpoint. When batch cycle counting is selected, the totalizer and totalizer setpoint are converted to six digits of operation. Use the up-arrow (U) key to select the Operating mode of the totalizer.

Submenu 22 - Totalizer Control Inputs

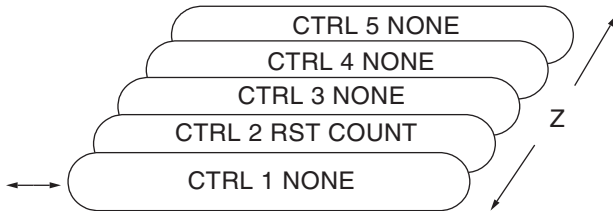

Press 1 through 5 to access Control Input 1 through Control Input 5.

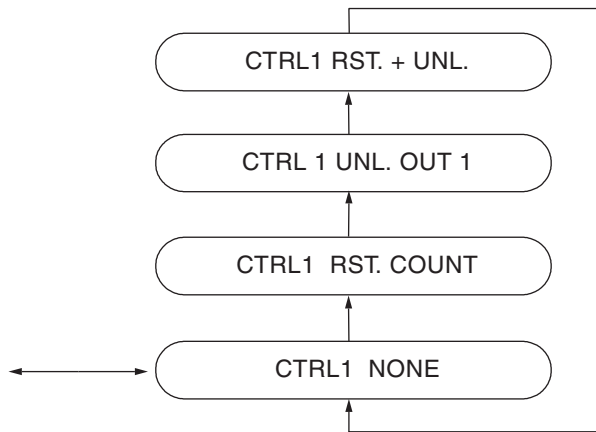

Same selections for CTRL 2 through CTRL 5.

Any of the five rear terminal control inputs can be programmed to perform a function on the totalizing operation of this control. A control input is selected by pressing Front Panel Keys 1, 2, 3, 4, or 5. Key 1 selects Control Input 1, Key 2 selects Control Input 2, etc. When a control input terminal has been selected, it is shown on the left side of the display and its function is shown on the right side of the display. The function that a control input terminal performs can be changed by pressing the up-arrow (U) key. The functions that can be assigned to an input are: None, Reset Count (Totalizer count only), Unlatch Output Transistor 1 (UNL. OUT 1), or Reset Count & Unlatch Output Transistor 1 (RST. & UNL.)

The "Unlatch Output" selection will work only if the totalizer output is programmed to be a Quadrature Error Indication or a Totalizer Setpoint Alarm Output in Submenu 23.

Note: An input assigned to perform a function to the totalizer can also be assigned to perform additional functions to the ratemeter and the batch control in the *Ratemeter and Batch Control Program Menu* rows. If a control input is selected to be a Jog or Program Inhibit command in the *Program Other menu* row, it cannot be selected for any other functions.

A chart is shown on Page 19 to provide a convenient means of recording the tasks each control input has been assigned.

Submenu 23 - Output Transistor #1

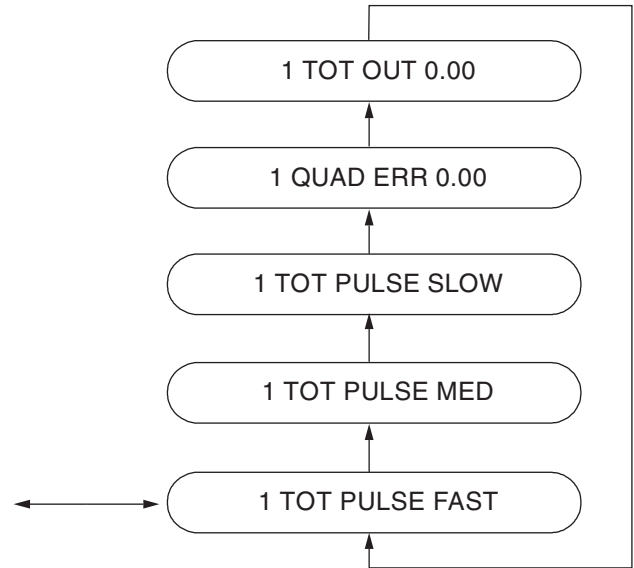

This output can be programmed to provide a pulse out for remote totalizing applications, quadrature error indication (when in the quadrature with error detection mode of operation), or a totalizer setpoint alarm indication.

To select the mode of operation, press the up-arrow (U) key. A timer value can be set when in the Quadrature Error Indication or Setpoint Alarm Indication mode. The timer can be set by: pressing the "CLR" key, pressing the 0-9 keys to program a new time value, and then pressing the "ENT" key to enter the new time value.

The totalizer has a buffer capable of storing ± 127 counts. The negative buffer is used to store negative counts in quadrature applications where jitter can occur. The positive buffer is used to store output pulses should the pulse output frequency temporarily exceed 1.5 kHz.

The buffer is saved at power down and is reset when totalizer is reset. This output is available even if the totalizer count input is batch.

The scaled pulse output occurs only when the pulse counter is positive.

When providing a pulse out, the output can be programmed for fast, medium, or slow pulse outputs. Refer to the following table for pulse widths and frequency ranges of the output pulses:

Program Mode (continued)

Fast: 75 μ s. on, 75 μ s. off; max. frequency = 1.5 kHz.

Med: 2 ms. on, 2 ms. off; max. frequency = 200 Hz.

Slow: 50 ms. on, 50 ms. off; max. frequency = 10 Hz.

When programmed to provide a setpoint indication, the transistor can be set to turn on for a specified time period (from 00.01 to 99.99 seconds) when the totalizer counter reaches the setpoint value. The timer can be disabled by setting a time value of 00.00. When the timer is disabled, the output remains latched on until an input or keyboard command unlatches the output.

When programmed to provide Quadrature Error Indication, the transistor can be set to turn on for a specified time period (from 00.01 to 99.99 seconds) when a quadrature error is detected. The timer can be disabled by setting a value of 00.00. When the timer is disabled, the output remains latched on until an output or keyboard command unlatches the output.

Programming Transistor 1 as the Quad Error Detect output does not inhibit the totalizer setpoint from being checked. The Auto Stop feature is still enabled.

Submenu 24 - Start and Reset Keys

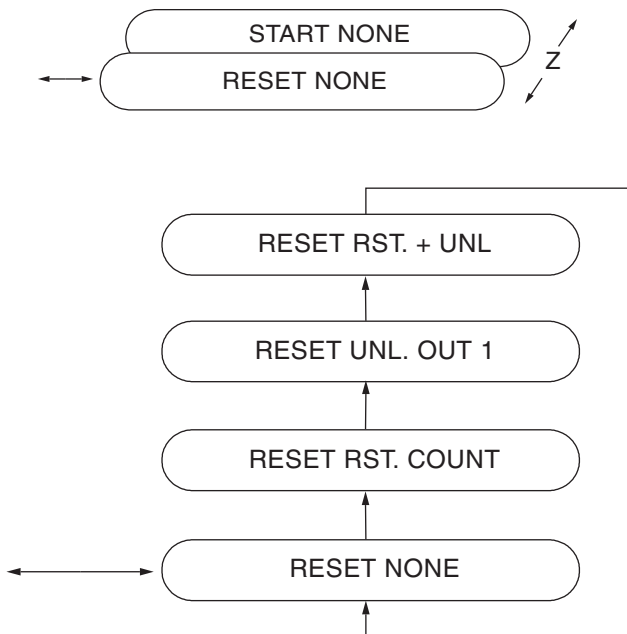

Same selection for Start key.

The Start and Reset keys can be programmed to perform various functions on the totalizing operation. Pressing the Start or Reset keys selects the key. The name of the key pressed is shown on the left side of the display and the function it performs is shown on the right side of the display. The function each key performs can be changed by pressing the up-arrow (\uparrow) key.

Start key functions which can be selected are: None, Reset Count, Unlatch Output, Reset Count & Unlatch Output. Reset key functions which can be selected are: None, Reset Count, Unlatch Output, and Reset Count & Unlatch Output.

Note: Keys assigned to perform a function to the totalizing operation of this control can also be assigned to perform additional functions to the ratemeter and the batch operations in the Ratemeter and Batch Program menu rows. A chart is shown on Page 18 to provide a convenient means of recording the tasks each key has been assigned.

Submenu 25 - Totalizer Decimal Point



The totalizer display can have a decimal point set in any of six positions. Use the up-arrow key to select the desired decimal point position. The decimal point selected here is shown in both the total count and totalizer setpoint.

Submenu 26 - Totalizer Auto Stop

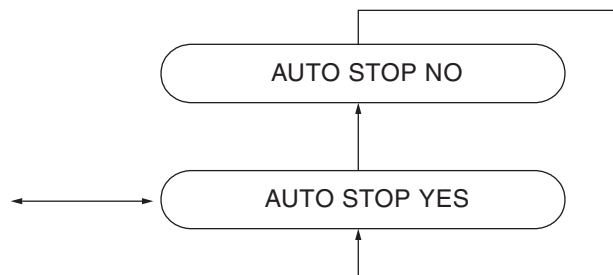

The totalizer has a setpoint which can be used to terminate automatic batching operations when the value of the totalizer reaches the total setpoint. Start commands via inputs, keys, or Auto Recycle are inhibited until the totalizer is reset or the totalizer setpoint is changed to a larger value. The Auto Stop function can be disabled, in which case the totalizer counts only.

Use the up-arrow (\uparrow) key to enable or disable the Auto Stop function.

Note: The setpoint is not checked if the totalizer is negative.

Program Mode (continued)

Program Ratemeter

Submenu 31 - Smoothing

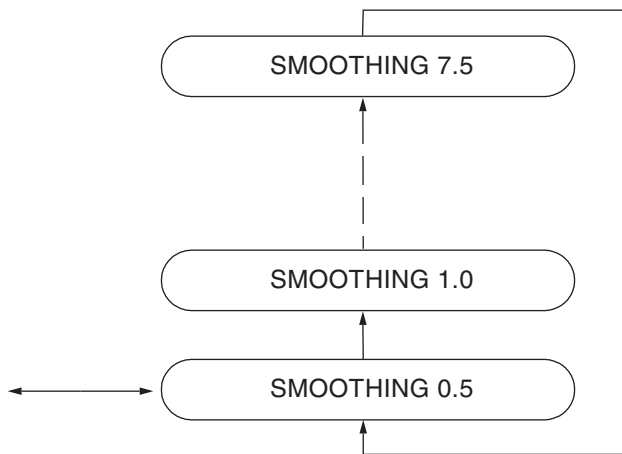

Rate is calculated and the rate display is updated every 0.5 seconds. When rate smoothing is selected to be greater than 0.5 seconds, the most recent rate calculation is averaged with the previous rate calculations that were made in the smoothing period. Use the up-arrow (Ù) key to select the amount of smoothing desired in 0.5 second increments up to 7.5 seconds.

Submenu 32 - Ratemeter Control Inputs

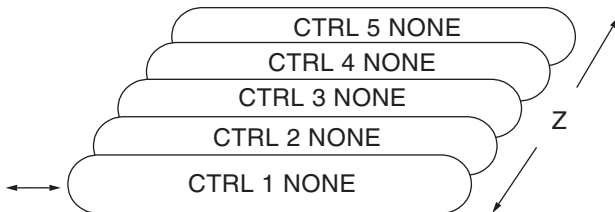

Press 1 through 5 to access Control Input 1 through Control Input 5.

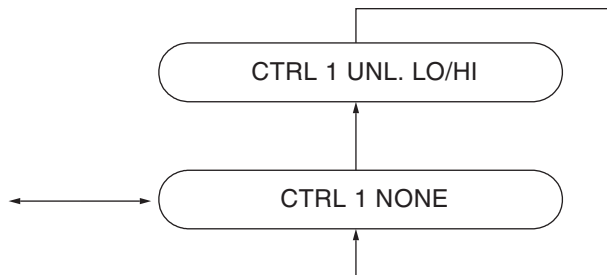

Same Selections for CTRL 2 through CTRL5.

Any of the five rear terminal control inputs can be programmed to perform a function on the ratemeter operation of this control. A control input is selected by pressing Front Panel Keys 1, 2, 3, 4, or 5. Key 1 selects Control Input 1, Key 2 selects Control Input 2, etc. When a control input terminal has been selected, it is shown on the left

side of the display and its function is shown on the right side of the display. The function that a control input terminal performs can be changed by pressing the up-arrow (Ù) key. The functions that can be assigned to an input are: None or Unlatch Hi/Lo Output Alarms.

Note: An input assigned to perform a function to the ratemeter can also be assigned to perform additional functions to the totalizer and the batch control in the Totalizer and Batch Control Program menu rows. If a control input is selected to be a Jog input or a Program Inhibit from the Program Other row, it cannot be selected to be anything else. A chart is shown on Page 19 to provide a convenient means of recording the tasks each control input has been assigned.

Submenu 33 - Ratemeter Hi and Lo Output Mode

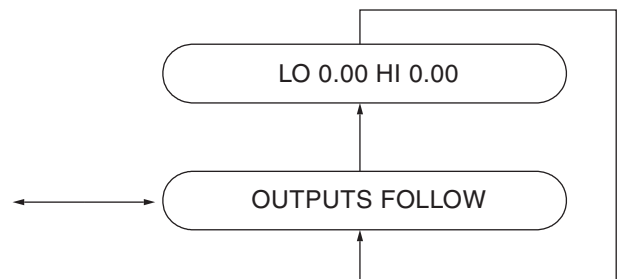

The ratemeter outputs can be programmed to: Follow, Timeout, or to Latch until a keyboard or input signal is received.

In the Follow mode of operation, the rate is compared to the Hi and Lo setpoints after each rate update. If an output is turned on, it remains on until the next rate update occurs and then the output is either left on or turned off depending on the comparison of the new rate reading with the setpoints.

In the Timeout mode of operation, the outputs can be programmed to turn on for 00.01 to 99.99 seconds. Programming a value of 00.00 disables the timer and causes the outputs to latch on until unlatched by the keyboard or input signal.

Use the up-arrow (Ù) key to select the Output mode of operation.

Use the "<" or ">" key to select the high or low output. The word "LO" or "HI" will flash when selected. Use the "CLR", 0-9, and "ENT" keys to enter timer values for both outputs.

Submenu 34 - Ratemeter Reset and Stop Keys

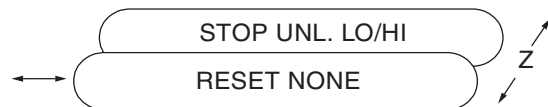

Program Mode (continued)

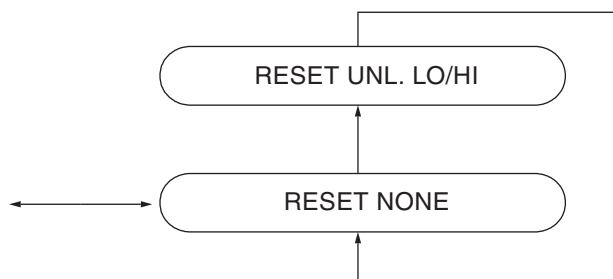

Same selection for Stop key.

The Stop and Reset keys can be programmed to perform various functions on the ratemeter. Pressing the Stop or Reset keys selects the key. The name of the key pressed is shown on the left side of the display and the function it performs is shown on the right side of the display. The function each key performs can be changed by pressing the up-arrow (U) key. Stop and Reset key functions which can be selected are: None or Unlatch Hi/Lo Alarms.

Note: Keys assigned to perform a function to the ratemeter operation of this control can also be assigned to perform additional functions to the totalizer and the batch operations in the Totalizer and Batch Program menu rows. A chart is shown on Page 18 to provide a convenient means of recording the tasks each key has been assigned.

Submenu 35 - Ratemeter Decimal Point



The ratemeter can have a decimal point set in any of five positions. Use the up-arrow (U) key to select the desired decimal point position. The decimal point selected here is shown in the rate display, the rate Hi/Lo setpoints and the rate 4-20 mA output 4 and 20 mA setpoints.

Submenu 36 - Ratemeter Lo Alarm Delay



Range 0.0 to 9.9 sec.

The Lo Rate output can be disabled for a time period at the start of each batch cycle. The timer can be set for 0.0 to 9.9 seconds. Use the "CLR", 0-9, and "ENT" keys to enter a new time delay value.

When the Lo output is to remain on when there is no flow input, the timeout should be either in the Follow mode or the timeout should be greater than the rate at zero time. This will ensure that the output does not turn off before the next 1/2 second update or rate zero timeout.

The Lo Alarm delay feature works only if the Lo Rate Alarm is selected to be start enabled.

Upon exit from the Program mode or power-up, the Lo Alarm is inhibited for the length of the Lo Alarm delay. The delay should be programmed to keep the output from turning on immediately upon power-up.

Submenu 37 - Ratemeter Zero Timeout



Range 1 to 15 sec.

The ratemeter displays zero rate when the time interval between input pulses exceeds the programmed Rate Zero time. The timer can be set from 1 to 15 seconds. Use the "CLR", 0-9, and "ENT" keys to enter a new timer value.

Submenu 38 - Rate Display Header



Range A to Z, blank, /, or #.

The Rate Display Header (up to four characters) can be programmed into the unit and will be shown along with the rate value and rate setpoints on the display. If the rate data exceeds four digits, or if the number of digits on the left half of the split screen display is six digits or more and the rate data is four digits, the rate header will be shifted off the display in the dual display mode of viewing data.

Use the "<" and ">" keys to cause the selected character to blink. Then use the "U" key to scroll through the options. The permitted choices are: A-Z, space, /, or #. If a three-character header is desired, put the space in the left most position of the rate header.

Submenu 39 - Lo Rate Alarm

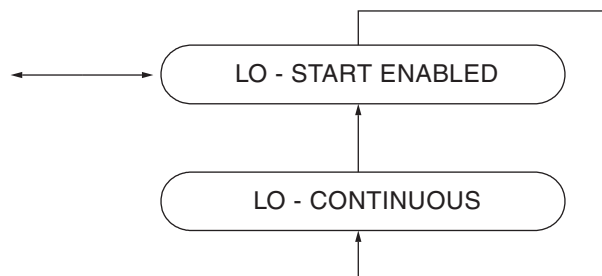

The Lo Rate Alarm can be selected to function continuously or only during a batch (start-enabled). Use the up-arrow (U) key to toggle the selection.

If the alarm is selected to function continuously, it will trigger whenever the flow rate falls below the setpoint value. This allows the FloMate to be used as a continuous Hi/Lo rate alarm indicator.

Program Mode (continued)

If the alarm is selected to be start enabled, it will trigger only during a batch cycle.

The Lo Alarm Delay (Submenu 36) should be programmed to keep the Lo Output from turning on immediately on power-up or at the start of a batch. The Lo Alarm Delay feature works only if the Lo Rate alarm is selected to be start enabled.

The Hi Rate alarm will always function continuously.

Program Batch Control

Submenu 41 - First Trip Function

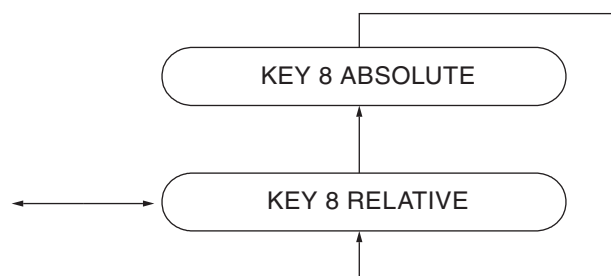

The batch control can have the First Trip Point configured as either a relative number or an absolute number. When selected to be an absolute number, the output deactuates when the count = the First Trip value. When selected as a relative value, the output deactuates when the count = batch size setpoint - the First Trip value. Use the up-arrow (U) key to select the appropriate configuration.

The unit cannot start if the batch counter is \geq batch size. If the unit is programmed for actual or remaining and the count is in the wrong direction (count w/dir), coincidence will be delayed until the counter rolls over.

Note: Batching functions operate only when the count is positive.

Submenu 42 - Batch Display

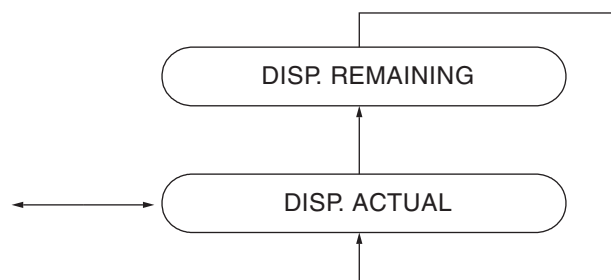

The batch display can be selected to show the amount dispensed or the amount remaining by using the up-arrow (U) key. When "DISP. ACTUAL" has been selected, the batch control resets to zero and counts up.

When "DISP. REMAINING" has been selected, the batch control resets to the final setpoint and counts down.

Submenu 43 - Batch Control Inputs

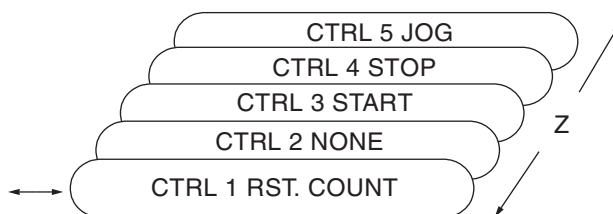

Press 1 through 5 to access Control Input 1 through Control Input 5.

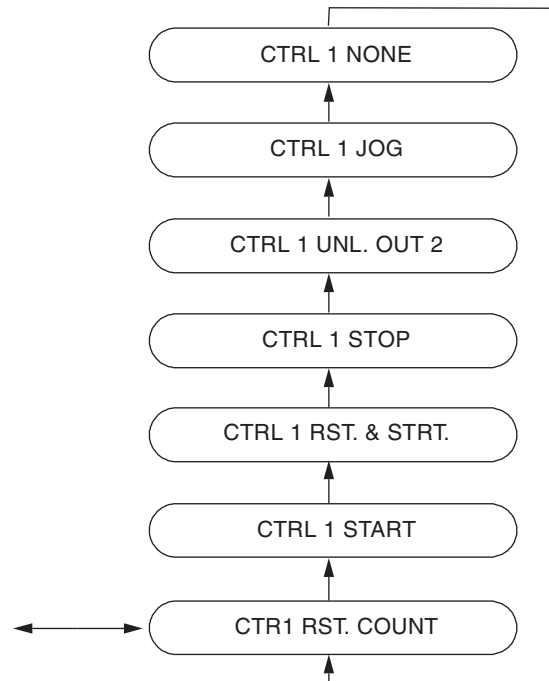

Same selections for CTRL 2 through CTRL 5.

Any of the five rear terminal control inputs can be programmed to perform a function on the batching operation of this control. A control input is selected by pressing Front Panel Keys 1, 2, 3, 4, or 5. Key 1 selects Control Input 1, Key 2 selects Control Input 2, etc. When a control input terminal has been selected, it is shown on the left side of the display and its function is shown on the right side of the display. The function that a control input terminal performs can be changed by pressing the up-arrow (U) key.

The functions that can be assigned to an input are None, Reset Count (Batch count only), Start, Reset & Start, Stop, Unlatch Output Transistor 2, and Jog.

The Jog option activates the appropriate output for the length of time the Jog input is applied.

Note: An input assigned to perform a function to the batch control can also be assigned to perform additional functions to the ratemeter and the totalizer in the Ratemeter and Totalizer Program menu rows. If a control input is selected to be a Jog or Program Inhibit from the Program

Program Mode (continued)

Other menu row, it cannot be selected to be anything else. A chart is shown on Page 19 to provide a convenient means of recording the tasks each control input has been assigned.

Submenu 44 - Batch Control Start, Stop and Reset Keys

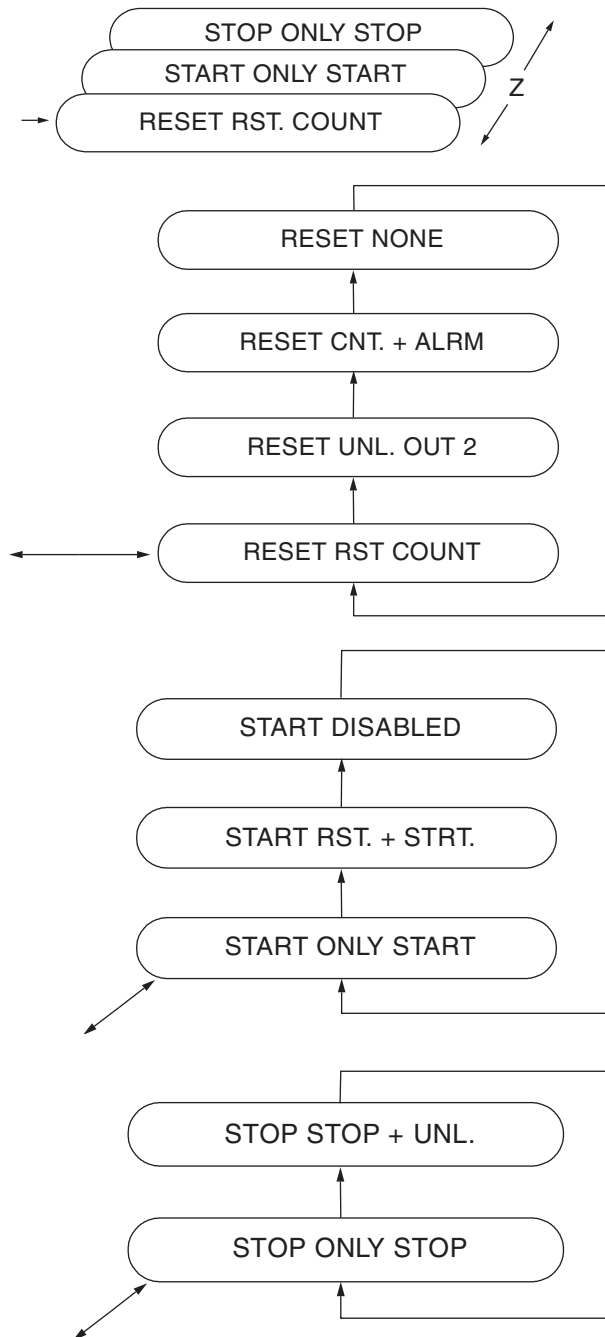

The Start, Stop, and Reset keys can be programmed to perform various functions on the batching operation of this control. Pressing the Start, Stop, or Reset keys selects the key. The name of the key pressed is shown on the left side of the display and the function it performs is shown on the right side of the display. The function each

key performs can be changed by pressing the up-arrow (U) key.

Start key functions which can be selected are Disabled, Start, and Reset & Start. Stop key functions which can be selected are Stop or Stop and Unlatch Output Transistor 2 (STOP & UNL.).

Reset key functions which can be selected are None, Reset Count, Unlatch, Reset Count, and Unlatch Output Transistor 2.

Note: Keys assigned to perform a function to the batching operation of this control can also be assigned to perform additional functions to the ratemeter and the totalizer in the Ratemeter and Totalizer Program menu rows.

A chart is shown on Page 18 to provide a convenient means of recording the tasks each key has been assigned.

Submenu 45 - Batch Decimal Point



The batch display can have a decimal point set in any of six positions. Use the up-arrow (U) key to select the desired decimal point position. The decimal point selected here is shown in the Batch Count, Final Trip Setpoint, First Trip Setpoint, and Overrun Setpoint data displays.

Submenu 46 - Batch Auto Recycle

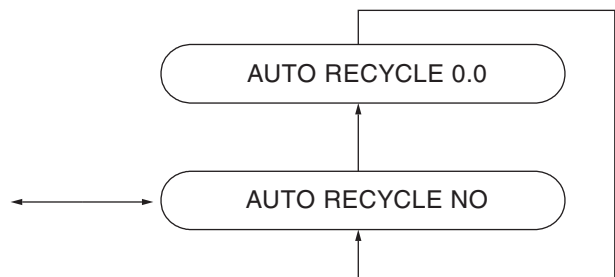

The batching operation can be programmed to Auto Recycle. The up-arrow (U) key selects "AUTO RECYCLE NO" or "AUTO RECYCLE XX.XX". When Auto Recycle with timeout is programmed, the batch counter automatically resets to zero when the Final Setpoint is reached.

A timer, with a range from 0.1 to 9.9 seconds, is set to determine the dwell time before the batch control automatically restarts. The dwell timer can be disabled by setting a time value of 0.0. When the timer is disabled, the batch counter automatically resets to zero when the final preset is reached but the batch control does not start until a start signal is received.

Auto Recycle mode of operation allows overrun counts caused by time delays from relays and valves to be automatically compensated for in succeeding batches. When "AUTO RECYCLE NO" is selected, the batch has to be reset before another batch can be run.

Program Mode (continued)

Submenu 47 - Batch Offset



Range 0 to 999999.

The batch count can be made to reset to a number other than zero by entering a number into the offset menu. To enter an offset number, press the “CLR” key, press the 0 through 9 keys, and press the “ENT” key.

Note: The offset number is subtracted from the final setpoint or batch size when the Count Remaining display mode has been selected.

Submenu 48 - Batch Overrun Setpoint



This is a setpoint that can be programmed to turn on the Batch Overrun alarm. It can be up to a six-digit number. The output is compared with the Overrun Setpoint every 10 msec or after the Batch = the Batch Size Setpoint.

The Overrun Setpoint is set to a number larger than the expected overrun counts that would occur under normal operating conditions. Should counts continue to occur and the count value reaches the Overrun Setpoint, the overrun output turns on.

Submenu 49 - Output Transistor 2

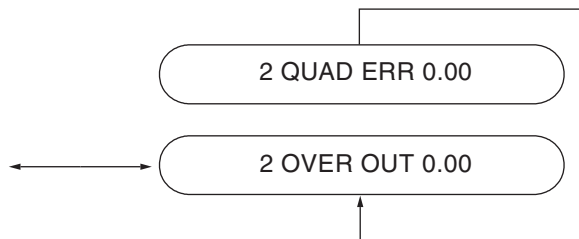

Range 0.00 to 99.99.

This transistor can be programmed to be the Batch Overrun Alarm output or a Quadrature Error Indication output.

When selected to be the Overrun output, it becomes enabled after Batch = Batch Size + Overrun. When programmed to provide Quadrature Error Indication, the transistor can be set to be turned on when a quadrature error is detected. Use “Ù” to select Quad/Overrun.

This output can be programmed to timeout from 00.01 to 99.99 seconds. The timer can be disabled by setting a time value of 00.00. When the timer is disabled, the output remains latched on until an input or keyboard command unlatches the output. To enter a timer value, press the “CLR” key, press the 0-9 keys to select the new timer value, and press the “ENT” key to enter the new timer value.

Programming Transistor 2 as the Quad Error Detect output does not inhibit the overrun setpoint from being checked.

Program Other

Submenu 51 - Setpoint / Batch Size Lock

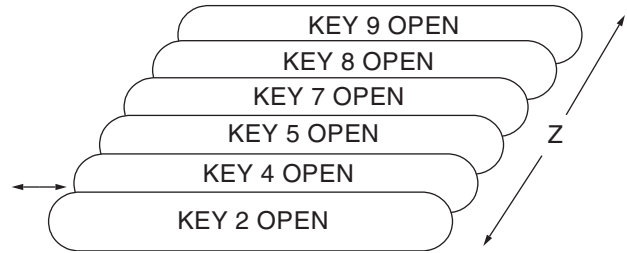

Press 2, 4, 5, 7, 8, 9 to access Keys 2, 4, 5, 7, 8, 9.

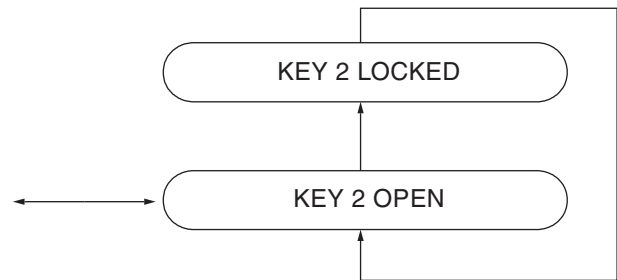

Same selections for Keys 4, 5, 8, 9.

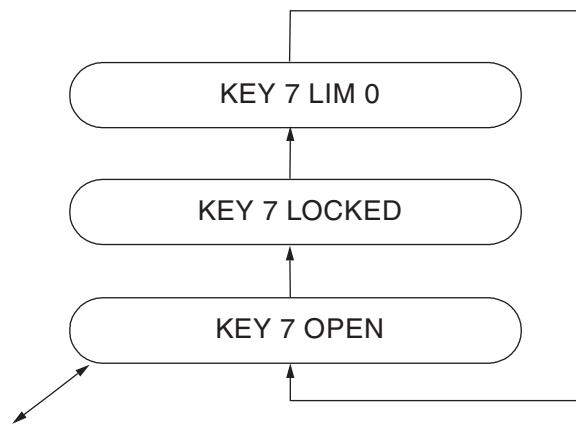

Range 0 to 999999.

The Total, Rate Hi/Lo, First Trip, Final Trip, Batch Size, and Overrun setpoints can be selectively locked to their current value. Use number keys 2, 4, 5, 7, 8, and 9 to select a setpoint. Use the up-arrow (Ù) key to select if the setpoint should be locked to its current value or left open for operator changeability.

The batch size setpoint can be programmed to have a maximum Limit value. Numbers larger than the Limit are not accepted into the control and an error message is displayed advising of the condition. The batch size setpoint limit is set by first pressing Key 7, then selecting Limit using the up-arrow (Ù) key. Enter the limit by using the “CLR”, 0-9, and “ENT” keys.

Program Mode (continued)

Submenu 52 - Password



Range 0 to 999999.

A password can be programmed into the unit to provide password-protected access to the Program mode. The unit, as it comes from the factory, does not require the entry of a password to gain access to the Program mode. This is accomplished by programming all zeros into the password data field. Entering a number from one to six digits in length into the password data field activates the password-protected access to the Program mode. To enter a password, press the “CLR” key, enter the new password, and press the “ENT” key. See Submenu 57 for hardware program inhibit information.

On entry into the Program mode, all outputs are turned off. If it is required that the operator not be able to turn off the transistor outputs in this manner, a password should be programmed. When exiting the Program mode, the outputs are not turned on unless triggered.

Submenu 53 - Communication Baud Rate and Parity

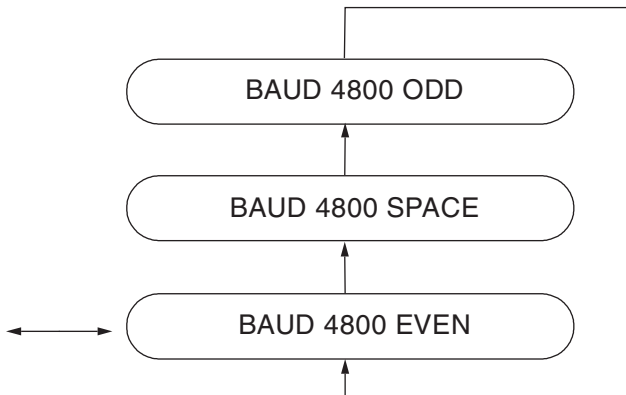

The baud rate and parity are set in this menu. Enter a baud rate of 1200, 2400, 4800 or 9600 by using the “CLR”, 0-9, and “ENT” keys. Enter “EVEN”, “ODD”, or “SPACE” parity by using the up-arrow key.

Submenu 54 - Unit ID number and Response Delay Time

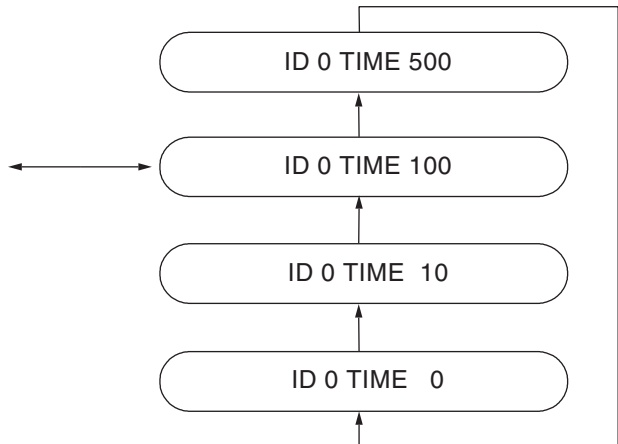

The unit identification number is set in this menu. Each unit on the communication bus must have a unique identifying number. This number can have a value of 1 through 255. Enter the units ID by using the “CLR”, 0-9, and “ENT” keys. The length of time before the control responds to communication requests can be set to accommodate various types of computer equipment. Delay times of 0, 10, 100, and 500 ms can be selected by using the up-arrow (U) key. The factory default is 100 ms.

Submenu 55 - Count Mode

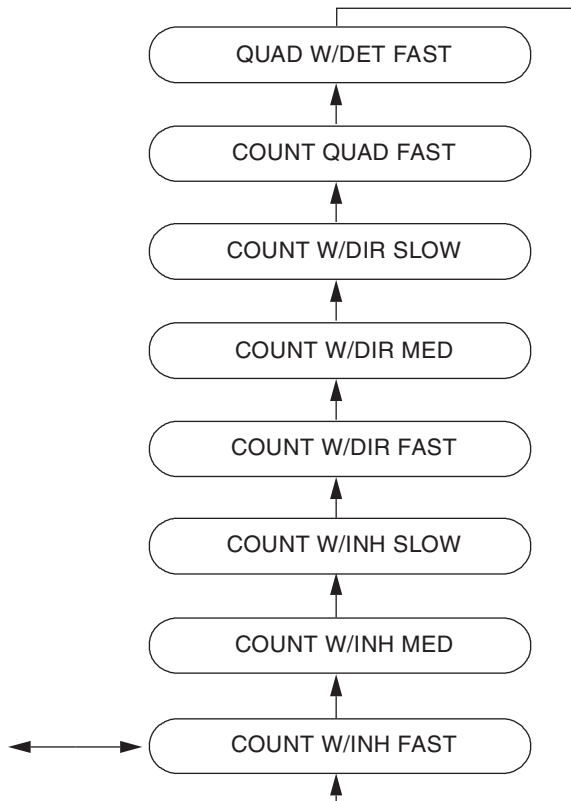

Program Mode (continued)

The FloMate has the capability to accept pulses from single-channel or dual-channel flow meters. Single-channel input will allow unidirectional counting only. With a dual-channel input, the pulses can be used as Counting with Inhibit, Counting with Direction, or Quadrature. The mode of pulse inputs can be selected in this menu.

Use the up-arrow (↑) key to program the unit to select the appropriate type of signal inputs. Please refer to the following list for maximum frequency inputs for each mode:

Count with Inhibit	Fast	0 - 7.0 kHz
Count with Inhibit	Med	0 - 400 Hz
Count with Inhibit	Slow	0 - 40 Hz
Count with Direction	Fast	0 - 7.0 kHz
Count with Direction	Med	0 - 400 Hz
Count with Direction	Slow	0 - 40 Hz
Count in Quadrature	Fast	0 - 4.5 kHz
Count in Quadrature	Fast	0 - 3.75 kHz
with Error Detection		

When using single-channel input, Channel A is connected to the pulse output from the flowmeter. This will allow unidirectional counting only. Select Count with Inhibit or Count with Direction. Channel B is not connected.

In the Count with Inhibit mode, Channel A is connected to the pulse output from the flowmeter and Channel B is used to inhibit counting via a contact closure to ground. When Channel B is pulled to ground, the FloMate stops counting pulses but the ratemeter is still active.

In the Count with Direction mode, Channel A is connected to the pulse output from the flowmeter and Channel B is connected to the direction output. This allows the FloMate to show bidirectional flow. First Trip and Final Trip setpoints are not checked if the counter is negative. The maximum number of negative counts is 90000. The display will flash at -60000 counts and the counter will stop counting at -90000.

If the unit is in the Display Actual mode, the unit will count up when Channel B is open. If the unit is in the Display Remaining mode, the unit will count down when Channel B is open.

When using the Quadrature mode, Both Channel A and B are connected to pulse outputs. If Channel A leads Channel B, then the flow is in the forward direction. If Channel B leads Channel A, then the flow is in the reverse direction.

If the FloMate is in the Quadrature with Error Detection mode, then it will signal an error if it receives three consecutive pulses on either Channel A or Channel B inputs. When this occurs, a message will be displayed ("QUAD ERROR DET") and the quadrature error output is activated; Transistor 1 and/or 2, depending on how the FloMate is programmed.

Note: The internal error counters are reset on start and power-up.

Submenu 56 - Outputs

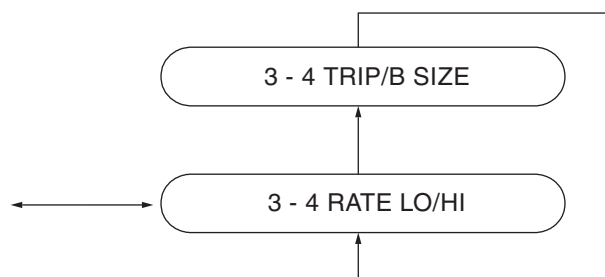

The functions of Output Transistors 3 and 4 and Relays K1 & K2 are interchangeable. Use the up-arrow (↑) key to select the appropriate mode.

Transistor Outputs 3 and 4 will be Lo/Hi Rate Alarm outputs while Relays K1 and K2 are Batch Control (First Trip and Final Trip) Setpoint outputs.

or

Transistor Outputs 3 and 4 will be Batch Control (First Trip and Final Trip) Setpoint outputs while Relays K1 and K2 are Lo/Hi Rate Alarm outputs.

Submenu 57 Program Inhibit

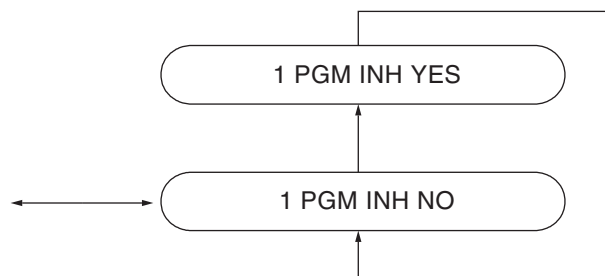
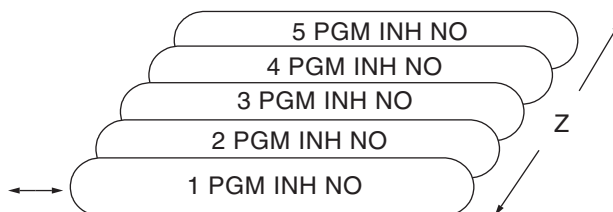

Any of the control inputs can be used as a Program Inhibit input. When selected and activated (input is tied low), all entry into the programming mode is inhibited. Even if the password = 0, the Program mode cannot be entered. If the user tries to enter the Program mode while the program inhibit is active, the following message is displayed for one second: "PGM INH ACTIVE".

When selected for program inhibit, a control input can not be used for any other function. If the unit is programmed to have additional functions along with program inhibit, the error message "PGM INH CONFLICT" is displayed and the Start/Reset, along with all of the control inputs, are inhibited.

Program Mode (continued)

The program inhibit does not affect communications and programming via communications is always enabled.

If the control input is programmed for Program Inhibit, "CTRL IN DISABLED" is displayed when the input is first activated indicating that it is not programmed for any other functions related to the totalizer, ratemeter, or batch control.

User Programming Reference Charts

Start, Stop, and Reset Keys

The Start, Stop, and Reset keys are programmable to perform different tasks for the batch control, totalizer,

and ratemeter functions of the unit. The Start and Stop keys can be programmed to perform up to two tasks, whereas the Reset key can perform up to three tasks. The keys can be programmed to perform only one task under each of the three major control functions shown below. The following table lists the tasks that can be selected.

Notes: - Start is dedicated to Unlatch Output Transistor 2.

- A Start input always latches the First Trip and Final Trip Batch outputs if within range.

Key	Control Function		
	Batch	Rate	Total
Start	<input type="checkbox"/> Disabled <input type="checkbox"/> Only Start <input type="checkbox"/> Reset & Start		<input type="checkbox"/> None <input type="checkbox"/> Reset Count <input type="checkbox"/> Unlatch Output <input type="checkbox"/> Reset & Unlatch
Stop	<input type="checkbox"/> Only Stop <input type="checkbox"/> Stop & Unlatch Transistor 2	<input type="checkbox"/> None <input type="checkbox"/> Unlatch Hi/Lo Alarms	
Reset	<input type="checkbox"/> None <input type="checkbox"/> Reset Count <input type="checkbox"/> Unlatch Transistor 2 <input type="checkbox"/> Reset Count & Alarm	<input type="checkbox"/> None <input type="checkbox"/> Unlatch Hi/Lo Alarms	<input type="checkbox"/> None <input type="checkbox"/> Reset Count <input type="checkbox"/> Unlatch Output <input type="checkbox"/> Reset & Unlatch

Program Mode (continued)

Control Inputs

There are five control inputs which can be programmed to any of the functions shown in the following chart. An input can be assigned up to three tasks but only one task can be assigned under each of the three control functions shown below. The Jog task and Program Inhibit are exceptions. If an input is assigned the Jog task or a Program Inhibit, it is not allowed to be assigned additional tasks.

Notes: - A Start input always latches the First Trip and Batch outputs if within range.

- All transistors and relays are turned off and the analog output goes to 4 mA while in the Program mode.

- The Scaled Pulse output buffer is cleared when the Total/Cycle counter is reset.

- If an output is not programmed to latch, a control input should not be programmed to unlatch it.

Control Input	Control Functions				
	Batch		Rate	Total	Other
1	<input type="checkbox"/> None <input type="checkbox"/> Reset Count <input type="checkbox"/> Start <input type="checkbox"/> Reset and Start	<input type="checkbox"/> Stop <input type="checkbox"/> Unlatch Transistor 2 <input type="checkbox"/> Jog	<input type="checkbox"/> None <input type="checkbox"/> Unlatch Hi/Lo Alarms	<input type="checkbox"/> None <input type="checkbox"/> Reset Count <input type="checkbox"/> Unlatch Output 1 <input type="checkbox"/> Reset & Unlatch	<input type="checkbox"/> Program Inhibit
2	<input type="checkbox"/> None <input type="checkbox"/> Reset Count <input type="checkbox"/> Start <input type="checkbox"/> Reset and Start	<input type="checkbox"/> Stop <input type="checkbox"/> Unlatch Transistor 2 <input type="checkbox"/> Jog	<input type="checkbox"/> None <input type="checkbox"/> Unlatch Hi/Lo Alarms	<input type="checkbox"/> None <input type="checkbox"/> Reset Count <input type="checkbox"/> Unlatch Output 1 <input type="checkbox"/> Reset & Unlatch	<input type="checkbox"/> Program Inhibit
3	<input type="checkbox"/> None <input type="checkbox"/> Reset Count <input type="checkbox"/> Start <input type="checkbox"/> Reset and Start	<input type="checkbox"/> Stop <input type="checkbox"/> Unlatch Transistor 2 <input type="checkbox"/> Jog	<input type="checkbox"/> None <input type="checkbox"/> Unlatch Hi/Lo Alarms	<input type="checkbox"/> None <input type="checkbox"/> Reset Count <input type="checkbox"/> Unlatch Output 1 <input type="checkbox"/> Reset & Unlatch	<input type="checkbox"/> Program Inhibit
4	<input type="checkbox"/> None <input type="checkbox"/> Reset Count <input type="checkbox"/> Start <input type="checkbox"/> Reset and Start	<input type="checkbox"/> Stop <input type="checkbox"/> Unlatch Transistor 2 <input type="checkbox"/> Jog	<input type="checkbox"/> None <input type="checkbox"/> Unlatch Hi/Lo Alarms	<input type="checkbox"/> None <input type="checkbox"/> Reset Count <input type="checkbox"/> Unlatch Output 1 <input type="checkbox"/> Reset & Unlatch	<input type="checkbox"/> Program Inhibit
5	<input type="checkbox"/> None <input type="checkbox"/> Reset Count <input type="checkbox"/> Start <input type="checkbox"/> Reset and Start	<input type="checkbox"/> Stop <input type="checkbox"/> Unlatch Transistor 2 <input type="checkbox"/> Jog	<input type="checkbox"/> None <input type="checkbox"/> Unlatch Hi/Lo Alarms	<input type="checkbox"/> None <input type="checkbox"/> Reset Count <input type="checkbox"/> Unlatch Output 1 <input type="checkbox"/> Reset & Unlatch	<input type="checkbox"/> Program Inhibit

Run Mode

Keys

Viewing Data

The default display can be configured as desired. The factory default is to show the batch size and the flow rate, with the units of the flow rate being GPM. The following options exist for the left and right sides of the display:

Left	Right
BATCH	RATE
B SIZE	LO RATE
1 TRIP	HI RATE
F TRIP	BATCH
OVERRUN	B SIZE
ANA OUT	1 TRIP
—	F TRIP
TOTAL	OVERRUN
LO RATE	ANA OUT
HI RATE	

The items displayed on the display can be changed by pressing and holding down the “DP” key until the left side of the display starts to blink. Use the up-arrow (↑) key to scroll through the choices. Stop at the desired item. Use the “>” arrow to move to the right side of the display (it will blink), and use the up-arrow to select the data to be displayed on the right side. Pressing the “<” and “>” keys will toggle between the left and right side of the display. Return to the normal display by pressing the “DISPLAY” key or any numeric key.

Note: If “TOTAL” is displayed on the left side, then either “BATCH” or “RATE” must be shown on the right side, and the screen will automatically offer only these two choices.

Press the following keys in any order to display the data programmed in the FloMate control unit. This information is displayed for five seconds before the display reverts to the default display.

Key Pressed	Shown on Display (Example)
1 - TOTAL	TOTAL 123567890
2 - TOTAL SETPOINT	TOT P 1234567890
3 - RATE	RATE 115 GPM
4 - LO RATE	LO 100 GPM
5 - HI RATE	HI 9600 GPM
6 - BATCH	BATCH 9370
7 - BATCH SIZE	B SIZE 20000
8 - 1ST TRIP	1 TRIP 10
9 - FINAL TRIP	F TRIP 5
0 - DISPLAY (SHOWS 2 VALUES)	B 937 115 GPM

Additional data can be displayed by first depressing the up-arrow (↑) key and then the 0-9 keys. The number key must be pressed within three seconds of pressing the “↑” key or else the display reverts to the default screen.

Keys Pressed	Shown on Display (Example)
^1	B LIMIT 0
^2	OFFSET 0
^3	K FACTOR 1.000
^4	R FACTOR 1.00
^5	KmF HIGH 1.0000
^6	KmF LOW 1.0000
^7	OVERRUN 10
^8	ANA OUT PERCENT
^9	ANA OUT PERCENT
^0	SOFTWARE VERSION

Display Hold

Pressing the following keys causes the display to “freeze” the current value for approximately one second:

- 0 - Dual Display
- 1 - Totalizer Count
- 3 - Rate
- 6 - Batch Count

Counting continues in the background. After the hold time elapses, the display updates to the new current value(s) and continues normal run mode updating thereafter.

Entering Setpoints

Setpoint data can be entered from the Run mode into the following items:

Key	Title
2	TOTAL SETPOINT
4	LO RATE
5	HI RATE
7	BATCH SIZE
8	FIRST TRIP
9	FINAL TRIP

To enter data, select the setpoint to be changed by pressing the desired key. The setpoint label and data should now be shown on the display. Press “CLR”, 0-9 (key in the new number), and “ENT” key. The new value for the setpoint is now entered into the control. The “CLR” key must be pressed within five seconds of pressing the Setpoint key or the display will revert to the default display.

The setpoints can be locked in the Program mode such that the value cannot be changed in the Run mode. The Batch Size setpoint can be limited to a programmed value. Batch size setpoints of a greater value than the Limit will not be entered and the message “FINAL SP > LIMIT” is shown on the display. See Program Mode Submenu 51 for more information.

To enter setpoints, the unit must be stopped and not in Jog. Counting is disabled from the time the “CLR” key is pressed until the “ENT” key is pressed. The five-second default display timeout feature is inhibited if a setpoint is being programmed.

Start, Stop, and Reset Keys

The Start, Stop, and Reset keys are programmable to perform different tasks for the batch control, totalizer, and ratemeter functions of the unit. The Start and Stop keys can be programmed to perform up to two tasks where as the Reset key can perform up to three tasks. The keys

Run Mode (continued)

can be programmed to perform only one task under each of the three major control functions shown below. The following table lists the tasks that can be selected.

Note: The Start key is dedicated to unlatch Output Transistor 2.

Control Inputs

Key	Control Function		
	Batch	Rate	Total
Start	<input type="checkbox"/> Disabled <input type="checkbox"/> Only Start <input type="checkbox"/> Reset & Start		<input type="checkbox"/> None <input type="checkbox"/> Reset Count <input type="checkbox"/> Unlatch Output <input type="checkbox"/> Reset & Unlatch
Stop	<input type="checkbox"/> Only Stop <input type="checkbox"/> Stop & Unlatch Transistor 2	<input type="checkbox"/> None <input type="checkbox"/> Unlatch Hi/Lo Alarms	
Reset	<input type="checkbox"/> None <input type="checkbox"/> Reset Count <input type="checkbox"/> Unlatch Transistor 2 <input type="checkbox"/> Reset Count & Alarm	<input type="checkbox"/> None <input type="checkbox"/> Unlatch Hi/Lo Alarms	<input type="checkbox"/> None <input type="checkbox"/> Reset Count <input type="checkbox"/> Unlatch Output <input type="checkbox"/> Reset & Unlatch

There are five control inputs which can be programmed to any of the functions shown in the chart below. An input can be assigned up to three tasks but only one task can be assigned under each of the three control functions shown below. The Jog task and Program Inhibit functions are exceptions. If an input is assigned to the Jog task or to the Program Inhibit task, it is not allowed to be assigned additional tasks.

Note: The unit must be in a stopped condition before the Jog input will work. The Jog input actuates Relay K2 and Transistor 4 (it operates the same output as the Final Trip setpoint) for as long as the input is maintained. The unit will display the batch counter during this mode.

Note: The Stop input is a maintained input. When a Stop input key is present, it will override Start and Jog inputs.

Control Inputs and Keyboard Start/Reset/Stop Operating Conditions

Control Input	Control Functions				
	Batch	Rate	Total	Other	
1	<input type="checkbox"/> None <input type="checkbox"/> Reset Count <input type="checkbox"/> Start <input type="checkbox"/> Reset and Start	<input type="checkbox"/> Stop <input type="checkbox"/> Unlatch Transistor 2 <input type="checkbox"/> Jog	<input type="checkbox"/> None <input type="checkbox"/> Unlatch Hi/Lo Alarms	<input type="checkbox"/> None <input type="checkbox"/> Reset Count <input type="checkbox"/> Unlatch Output 1 <input type="checkbox"/> Reset & Unlatch	<input type="checkbox"/> Program Inhibit
2	<input type="checkbox"/> None <input type="checkbox"/> Reset Count <input type="checkbox"/> Start <input type="checkbox"/> Reset and Start	<input type="checkbox"/> Stop <input type="checkbox"/> Unlatch Transistor 2 <input type="checkbox"/> Jog	<input type="checkbox"/> None <input type="checkbox"/> Unlatch Hi/Lo Alarms	<input type="checkbox"/> None <input type="checkbox"/> Reset Count <input type="checkbox"/> Unlatch Output 1 <input type="checkbox"/> Reset & Unlatch	<input type="checkbox"/> Program Inhibit
3	<input type="checkbox"/> None <input type="checkbox"/> Reset Count <input type="checkbox"/> Start <input type="checkbox"/> Reset and Start	<input type="checkbox"/> Stop <input type="checkbox"/> Unlatch Transistor 2 <input type="checkbox"/> Jog	<input type="checkbox"/> None <input type="checkbox"/> Unlatch Hi/Lo Alarms	<input type="checkbox"/> None <input type="checkbox"/> Reset Count <input type="checkbox"/> Unlatch Output 1 <input type="checkbox"/> Reset & Unlatch	<input type="checkbox"/> Program Inhibit
4	<input type="checkbox"/> None <input type="checkbox"/> Reset Count <input type="checkbox"/> Start <input type="checkbox"/> Reset and Start	<input type="checkbox"/> Stop <input type="checkbox"/> Unlatch Transistor 2 <input type="checkbox"/> Jog	<input type="checkbox"/> None <input type="checkbox"/> Unlatch Hi/Lo Alarms	<input type="checkbox"/> None <input type="checkbox"/> Reset Count <input type="checkbox"/> Unlatch Output 1 <input type="checkbox"/> Reset & Unlatch	<input type="checkbox"/> Program Inhibit
5	<input type="checkbox"/> None <input type="checkbox"/> Reset Count <input type="checkbox"/> Start <input type="checkbox"/> Reset and Start	<input type="checkbox"/> Stop <input type="checkbox"/> Unlatch Transistor 2 <input type="checkbox"/> Jog	<input type="checkbox"/> None <input type="checkbox"/> Unlatch Hi/Lo Alarms	<input type="checkbox"/> None <input type="checkbox"/> Reset Count <input type="checkbox"/> Unlatch Output 1 <input type="checkbox"/> Reset & Unlatch	<input type="checkbox"/> Program Inhibit

Run Mode (continued)

Run Mode

Stop overrides BOTH the Start and Jog functions.

Reset BATCH Counter	(Stopped)
Reset TOTALIZER/CYCLE Counter	(Stopped)
Unlatch TOTALIZER/CYCLE/QUADRATURE Transistor	(Anytime)
Unlatch RATE LO/Hi Outputs	(Anytime)
Unlatch OVERRUN/QUADRATURE Transistor	(Anytime)
START/RESUME	(Stopped)
STOP Maintained Input	(Anytime)
JOG Maintained Input	(Stopped)
Program Inhibit	(Anytime)

Program Mode

All control inputs are disabled in the Program mode. Start/Reset/Stop keys perform programming functions only.

Relay/Transistor Outputs

- K1 Energizes at start, de-energizes at the First Trip setpoint or stop; or it energizes when the Rate Lo Alarm output is activated, depending on how the unit is programmed.
- K2 Energizes at start, de-energizes at the Final Trip setpoint or stop. K2 is also the jog relay - it is energized when the Jog input is active; or it energizes when the Rate Hi Alarm output is activated, depending on how the unit is programmed.
- T1 Scaled Pulse/Totalizer/Quadrature Setpoint Output Transistor. As a scaled pulse output, this transistor provides a count pulse out to a remote counter while the totalizer is counting. As a totalizer setpoint output, this transistor turns on when the totalizer setpoint is reached. As a Quadrature Error alarm indicator, the transistor turns on when a quadrature error is detected.
- T2 Overrun Output/Quadrature Error Output Transistor. This transistor turns on when the batch overrun setpoint is reached. As a Quadrature Error alarm indicator, the transistor turns on when a quadrature error is detected.
- T3 Rate Lo Alarm/Batch First Trip Output Transistor. This transistor turns on at the rate update if the calculated rate is less than the Lo rate setpoint. Or when the First Trip setpoint is reached, depending on how the unit is programmed.
- T4 Rate Hi Alarm/Batch Final Trip Output Transistor. This transistor turns on at the rate update if the calculated rate is greater than the Hi rate setpoint or when the Final Trip setpoint is reached, depending on how the unit is programmed. T4 can also be the Jog output if so programmed.

The detailed submenu descriptions in the Program mode section give the options for turning the transistors off.

Messages

A number of messages are available for display during the Run mode or while the unit is entering the Run mode from a power-up or exiting from Program mode condition. They may inform the operator of an operating condition or alert the operator that a keyboard control input function was attempted and inhibited. Diagnostic messages may also be displayed while the unit is running self-test.

Batch Start/Stop Messages

- START - Start of batch cycle.
- RESUME - A batch has been started, stopped before the final setpoint, and started again.
- STOP - A batch has been started and the Stop key/ input is activated.

Run Mode Inhibit Messages

- INV - Invalid key.
- TOTAL STOP - Totalizer setpoint has been reached and Auto Stop is programmed.
- STOP ACTIVE - Stop input is maintained and a start is attempted.
- RUN ACTIVE - Unit already in start condition and a second start input is received.
- RECYCLE ACTIVE - Unit timing out during auto recycle and start is attempted.
- JOG ACTIVE - Unit in Jog and start attempted.
- BATCH > FINAL - Batch Count is greater than Final Trip setpoint, and a start is attempted.
- BATCH > SIZE - Batch Counter > Batch Size and a start is attempted.
- F TRIP ACTIVE - START/RESUME attempted after Final Trip coincidence, but before Batch Size coincidence.
- FINAL SP = ZERO - Batch Size setpoint has not been entered.
- FINAL > LIMIT - Batch Size setpoint is greater than Batch Limit.
- OFFSET > FINAL - Offset value is greater than the Batch Size setpoint.
- RTE LO SP >= HI - Rate Lo Alarm setpoint is greater than or equal to rate Hi Alarm setpoint.
- OVERRUN SP ERROR - Batch Size + Overrun > 999999 (reset mode)
0 - Overrun < Min. Neg. Value (Preset mode)
(unit not in Auto Recycle mode)

Run Mode (continued)

RM - Kmf HI RANGE - Either the rate multiplier or the K-Factor entered (or both) is too large. At the slowest count rate, the rate display will overflow.

RM - KMF LO RANGE - Either the rate multiplier or the K-Factor entered (or both) is too small. At the fastest count rate, the rate display will always be zero.

ANA OUTPUT ERROR - The 4 mA output rate is greater than the 20 mA output rate.

PW ERROR - If an invalid password is entered, this message is displayed for one second and the unit re-prompts.

PROGRAM INH ACTIVE - If the user tries to enter the Program mode while a Program Inhibit command is active, this message is displayed for one second.

QUAD ERROR DET - If the Quadrature with Error mode is selected, this message is displayed and the Quad Error outputs are activated.

CTRL IN DISABLED - If the control input is programmed for program inhibit, this message is displayed when the input is first activated indicating that it is not programmed for any functions related to the totalizer, ratemeter, or batch control.

PGM INH CONFLICT - If a control input is selected to be a program inhibit as well as some other task, this message is displayed and Start/Reset and all other control inputs are inhibited.

PULSE OVERFLOW - If the output misses counts whereby it cannot keep pace with the totalizer, this message is displayed for one second.

Power-up and Exit From Program Mode Inhibit Messages

B SIZE = 0 - Batch size is set to zero.

B SIZE > LIMIT - Batch size is greater than the batch size limit setpoint.

OFFSET > B SIZE - The offset value is greater than the batch size.

RATE LO SP >= HI - The Lo rate setpoint is greater than the Hi rate setpoint. Not displayed if Hi = 0.

JOG PGM ERROR - Jog function is programmed with another function.

LOW VOLTAGE - Low voltage condition.

Diagnostics

There are four tests of the electronics performed on power-up.

Test	Error Message
1. 16-bit ROM checksum	ROM CHECKSUM ERR
2. Internal RAM bit test	INT RAM BIT ERR
3. External RAM bit test	EXT RAM BIT ERR
4. External RAM checksum	STORE ERROR

Failure of Tests 1-3 indicates a fatal condition. The unit will not function and there is no way to recover from this situation.

Failure of Test 4 can be overcome by pressing the Stop key.

The operator should check the stored values to ensure that they are not corrupted. "VERIFY PGM DATA" is displayed for one second.

There is a high level programming watchdog test performed continuously. This test is used to ensure that no loop is entered that will never be exited. If this watchdog ever times out, the process is stopped and the error message "WATCHDOG TIMEOUT" is displayed. Pressing the Stop key will allow recovery from this error. Refer to Program Mode, Submenu 15 for additional information.

Serial Communications

Introduction to Serial Communications

Purpose

The FloMate is equipped with an RS-485 serial communication port for the purpose of allowing a computer to:

- Issue control commands such as start, stop, and reset.
- Query Run mode data such as count, rate, setpoints, etc.
- Load setpoints.
- Query and program all Program mode submenus except numbers 13, 15, 52, 53, and 54.

Description

The serial format follows the Opto 22 Optomux - protocol. This consists of a start character (>); a two-character unit ID number; a three-character command; data for the command, if applicable; a two-character checksum; and a termination character.

Each character is ten bits. The first bit is the start bit, followed by seven data bits (ASCII code), followed by the parity bit, and the tenth bit is the stop bit. If the unit is programmed to space parity, the unit ignores the received parity and transmits space parity. The unit ID number and the checksum are in ASCII hexadecimal and have a range of 00 to FF. The checksum is the two least significant hexadecimal digits of the sum of the ASCII values of the unit ID number, the command, and the data. All hexadecimal characters A through F must be in uppercase. All leading zeroes in data fields must be sent. Decimal points within the data field are indicated by an ASCII comma. Commas within data fields sent to the control are ignored. The termination character may be an ASCII carriage return or an ASCII decimal point.

Responses by the control consist of three possibilities:

1. A (acknowledge)
2. Ad.cc (acknowledge with data, d..., and checksum of the data, cc)
3. Nee (not acknowledge with a two-digit error code, ee)

Communications are momentarily disabled while exiting the Program mode and on initial power-up.

Example:

Command sent to control - >01SRT08A.

Where:

- > is the start character.
- 01 is the unit ID number.
- SRT is the three-character command (start).
- 0 is applicable data (start option - start only).
- 8A is the two least significant digits of the hexadecimal checksum.

0	1	S	R	T	0
---	---	---	---	---	---

$$30 + 31 + 53 + 52 + 54 + 30 = 18A \text{ hexadecimal}$$

- "." is the termination character.

Error Codes

Error codes consist of the following:

- | | |
|----|--|
| 01 | Invalid Command |
| 02 | Communication Checksum Error |
| 03 | Buffer Overrun Error |
| 05 | Data Format Error |
| 08 | Parity or Framing Error |
| 10 | In Run Mode, Command not Allowed |
| 11 | In Standby Mode, Command not Allowed |
| 12 | In Program Mode, Command not Allowed |
| 13 | Mode Already Active, Command not Allowed |
| 14 | Incorrect Totalizer Mode (Query Commands) |
| 15 | Unlatch Complete - Start Inhibited |
| 16 | Reset Complete - Start Inhibited |
| 17 | Unlatch and Reset Complete - Start Inhibited |
| 18 | Unlatch Complete - Reset and Start Inhibited |
| 19 | Reset and Start Inhibited |
| 20 | Start Inhibited |
| 21 | Data Out of Range |

Serial Commands

Classifications

All serial commands fall into one of five classifications. These classifications are:

1. Control Commands.
2. Query Run Data.
3. Load Run Data.
4. Query Program Data.
5. Load Program Data.

The control has three modes of operation: Standby mode, Run mode, and Program mode. The control will respond to specific commands only if the command is valid for the mode of operation the control is in when the command is received. Command validity is addressed in the following section and all specific commands are described in detail in the following tables.

Control Commands

There are five control commands. Four of them (Start, Stop, Enter Program mode, and Exit Program mode) are used to change the control's mode of operation. The following flow chart illustrates the validity and function of each control command and the validity of the other four command classifications in each mode of operation. Note that the control goes into the Standby mode when it powers up.

The fifth control command, Reset, does not change the control's mode of operation, but merely performs a reset and/or unlatch function while leaving the control in the Standby mode. The Start, Stop, and Reset control commands are suffixed by one or two digits (a or ab) which allow for secondary functions to occur along with the Start, Stop, and Reset function. All secondary functions are listed in the following control command table.

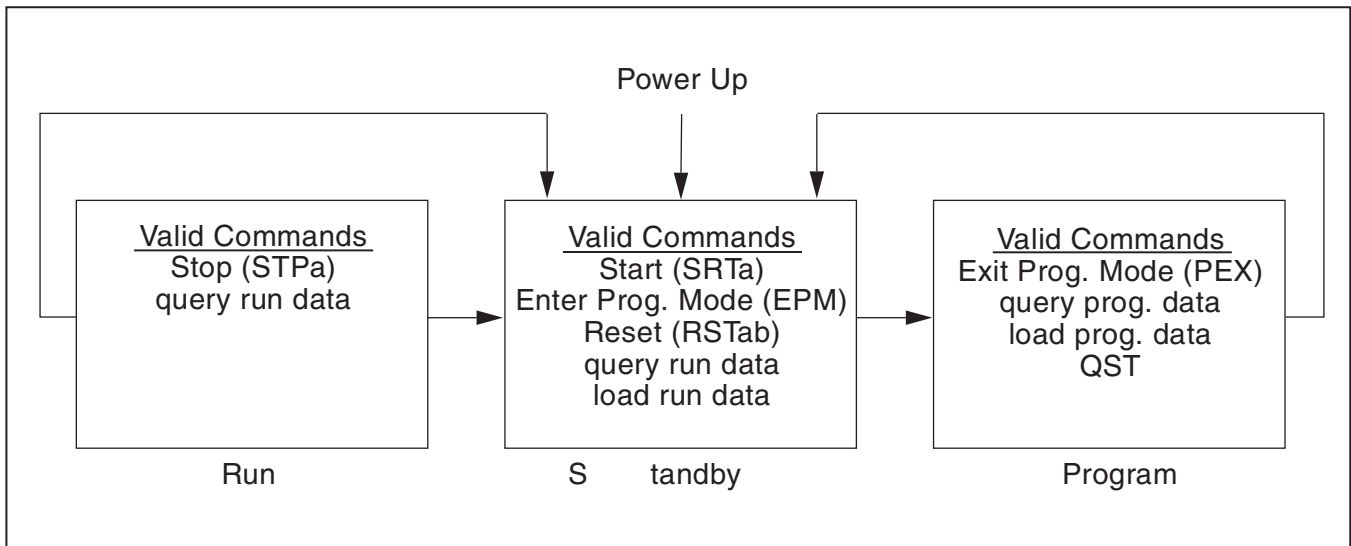

All commands in the following tables are preceded by the start character (>) and unit number and succeeded by the two-character checksum and carriage return.

The following control commands are supported by this control:

Command	Response	Description
SRTa	A	START COMMAND Where "a" determines functions to be performed. Start function is always performed if possible.
Digit "a" = 0 - Start Only = 1 - Reset Batch Counter = 2 - Reset Totalizer = 3 - Reset Batch Counter and Totalizer = 4 - Unlatch Transistor 1 Output = 5 - Reset Batch Counter and Unlatch Transistor 1 Output = 6 - Reset Totalizer and Unlatch Transistor 1 Output = 7 - Reset Batch Counter, Totalizer, and Unlatch Transistor 1 Output		
STPa	A	STOP COMMAND Where "a" determines functions to be performed. Stop function is always performed.

Serial Commands (continued)

Digit "a" = 0 - Stop Only
 = 1 - Unlatch Transistor 1 Output
 = 2 - Unlatch Rate Alarms
 = 3 - Unlatch Transistor 1 and Rate Alarms

RSTab A RESET COMMAND
 Where "ab" determine functions
 to be performed.

Digit "a" = 1 - Reset Batch Counter
 = 2 - Unlatch Transistor 1 Output
 = 3 - Reset Batch Counter and Unlatch Transistor 1 Output
 = 4 - Unlatch Rate Alarms
 = 5 - Reset Batch Counter and Unlatch Rate Alarms
 = 6 - Unlatch Transistor 1 Output and Rate Alarms
 = 7 - Reset Batch Counter, and Unlatch Transistor 1 Output and Rate Alarms

Digit "b" = 1 - Reset Totalizer
 = 2 - Unlatch Transistor 1 Output
 = 3 - Reset Totalizer and Unlatch Transistor 1 Output

EPM A ENTER PROGRAM MODE
 PEX A EXIT PROGRAM MODE

Query Run Data Commands

This classification of commands allows the computer to read run data information such as status, count, rate, setpoint, etc. These commands are valid in Run and Standby modes only, except for QST (query status) which is valid in all modes of operation.

The following Query Run Data commands are supported:

Command	Response	Description
QST	AST abcde	QUERY STATUS Where a = Current Mode = R - Run Mode = S - StandbyMode = P - Program Mode b = Transistor 1 Status = A - Output On = N - Output Off c = Transistor 2 Status = A - Alarm On = N - No Alarm d = Transistor 3 Status = A - Alarm On = N - No Alarm e = Transistor 4 Status = A - Alarm On = N - No Alarm
Rate Lo and Hi Status Indicates the alarms are either on Transistors 3 & 4 or the relays. "b" = N if scaled pulse output for Transistor 1		
QBC	ABCaaaaaa	QUERY BATCH COUNT where aaaaaa = Batch Count
QRT	ARTaaaaaa	QUERY RATE where aaaaaa = 5-digit Rate aaaaaa = 0aaaaa if Positive aaaaaa = -aaaaa if Negative ARTOVERFLOW = rate overflow (> 5 digits)

Serial Commands (continued)

QTC	ATCaaaaaaaa	QUERY TOTALIZER COUNT Where aaaaaaaaa = Totalizer Count (Totalizer Mode)
QCC	ACCaaaaaa	QUERY CYCLE COUNT Where aaaaaa = Cycle Count (Cycle Mode)
QRH	ARHaaaaaa	QUERY RATE HI SETPOINT Where aaaaaa = Rate Hi Setpoint
QRL	ARLaaaaaa	QUERY RATE LO SETPOINT Where aaaaaa = Rate Lo Setpoint
QBP	ABPaaaaaa	QUERY BATCH FIRST TRIP SETPOINT Where aaaaaa = Batch First Trip Setpoint
QBF	ABFaaaaaa	QUERY BATCH SIZE SETPOINT Where aaaaaa = Batch Size Setpoint
QBL	ABLaaaaaa	QUERY BATCH SETPOINT LIMIT Where aaaaaa = Batch Setpoint Limit
QOF	AOFaaaaaa	QUERY BATCH OFFSET Where aaaaaa = Batch Offset
QFT	AFTaaaaaa	QUERY FINAL TRIP SETPOINT Where aaaaaa = Batch F Trip Setpoint
QTS	ATSaaaaaaaa	QUERY TOTALIZER SETPOINT Where aaaaaaaaa = Totalizer Stpnt (Totalizer Mode)
QCS	ACSaaaaaa	QUERY CYCLE SETPOINT Where aaaaaa = Cycle Setpoint (Cycle Mode)
QAN	AAN aaa,a	QUERY ANALOG PERCENT Where aaa,a = percent to 100.0
QMD	Aa...	QUERY MENU DATA Where a... = Data Specified in Current Menu.
QAP	Aab c-. ab c... ...	QUERY ALL PROGRAM DATA Where a = Program Menu Row b = Program Menu Column c = Applicable Data

Load Run Data Commands

This classification of commands allows the computer to write setpoints to the control and specify the control's response to the QMD command. These commands are valid only in the Standby mode.

The following Load Run Data commands are supported:

Command	Response	Description
LRHaaaaaa	A	LOAD RATE HI SETPOINT where aaaaaa = Rate Hi 5-digit Setpoint
LRLaaaaaa	A	LOAD RATE LO SETPOINT where aaaaaa = Rate Lo 5-digit Setpoint
LBPaaaaa	A	LOAD BATCH FIRST TRIP SETPOINT where aaaaaa = Batch First Trip Stpt
LBFaaaaaa	A	LOAD BATCH SIZE SETPOINT where aaaaaa = Batch Size Setpoint
LFTaaaaaa	A	LOAD BATCH FINAL TRIP SETPOINT where aaaaaa = Batch Final Trip Stpt
LTSaaaaaaaa	A	LOAD TOTALIZER SETPOINT where aaaaaaaaa = Totalizer Stpnt (Totalizer Mode)

Serial Commands (continued)

or		
LCSaaaaaa	A	Where aaaaaa = Cycle Setpoint (Cycle Mode)
LCMabcd	A	LOAD COMMUNICATION MENU Where abcd determines the information that will be sent by the control when it is issued a QMD command. The following table illustrates the bit assignments for the available data. Setting the appropriate bits will cause that data to be sent. Default setting is "0000".
Digit "a" (0-F)	Bit 0 Bit 1 Bit 2 Bit 3	Status Batch Count Flow Rate Totalizer or Cycle Count
Digit "b" (0-F)	Bit 0 Bit 1 Bit 2 Bit 3	Batch 1st Trip Setpoint Batch Size Setpoint Batch Final Trip Setpoint Batch Limit Setpoint
Digit "c" (0-F)	Bit 0 Bit 1 Bit 2 Bit 3	Batch Offset Rate Low Setpoint Rate High Setpoint Totalizer or Cycle Counter Setpoint
Digit "d" (0-F)	Bit 0 Bit 1 Bit 2 Bit 3	K-Factor Rate Multiplier Batch Overrun Setpoint Analog Percent

Query Program Data/Load Program Data Commands

Query commands allow the computer to read program data from the control and load commands allow the computer to write program data to the control. Each command consists of an L (load) or a Q (query) and the two-digit submenu number of the Program mode submenu illustrated on Page 5. All Program mode submenus are serially-accessible except numbers 13, 15, 52, 53, and 54. These commands are valid only in the Program mode.

The following Program mode commands are supported by this control. Decimal points are not required by the command except for those program blocks which allow for a floating decimal point. All other program blocks will insert the decimal point in the correct location.

L11 aaaaa	A	Load K-Factor Where aaaaa = K-Factor (D.P.valid)
Example: L11 1,2345 loads K-Factor 1.2345		
Q11	A11aaaaa	Query K-Factor Where aaaaa = K-Factor
L12 aaaaaa	A	Load Rate Multiplier Where aaaaaa = Multiplier (D.P. valid)
Example: L12 1,2345 loads R-Factor 1.2345		
Q12	A 12 aaaaaa	Query Rate Multiplier Where aaaaaa = Multiplier
L14 aaaaaa bbbbbb	A	Load Analog Rate Where aaaaaa = 4 mA rate bbbbbb = 20 mA rate
Q14	A14 aaaaaa bbbbbb	Query Analog Rate Where aaaaaa = 4 mA rate bbbbbb = 20 mA rate

Serial Commands (continued)

L21 a	A	Load Totalizer Source Where a = 0 - Batch = 1 - Flow
Q21	A21 a	Query Totalizer Source Where a = 0 - Batch = 1 - Flow
L22 a b	A	Load Totalizer Control Input Where a = Control Input (1-5) b = 0 - No Function = 1 - Reset Totalizer = 2 - Unlatch Output = 3 - Reset and Unlatch
Q22	A22 a b ...	Query All Totalizer Control Inputs Where a = Control Input b = 0 - No Function = 1 - Reset Totalizer = 2 - Unlatch Output = 3 - Reset and Unlatch
L23 a bbbb	A	Load Totalizer Output Selection/Time Where a = 0 - Total Setpoint Output = 4 - Quad Error Output b = Output Time (00.00 - 99.99)
or		
L23 a	A	Where a = 1 - Pulse Fast = 2 - Pulse Medium = 3 - Pulse Slow
Q23	A23 a bbbb	Query Totalizer Output Selection Where a = 0 - Setpoint = 4 - Quad Error Output b = Output Time (00.00 - 99.99)
or		
Q23	A23 a	Where a = 1 - Pulse Fast = 2 - Pulse Medium = 3 - Pulse Slow
L24 a b	A	Load Totalizer Reset and Start Keys Where a = Reset Key Function = 0 - No Function = 1 - Reset Totalizer = 2 - Unlatch Output = 3 - Reset and Unlatch b = Start Key Function = 0 - No Function = 1 - Reset Totalizer = 2 - Unlatch Output = 3 - Reset and Unlatch
Q24	A24 a b	Query Totalizer Reset and Start Keys Where a = Reset Key Function = 0 - No Function = 1 - Reset Totalizer = 2 - Unlatch Output = 3 - Reset and Unlatch b = Start Key Function = 0 - No Function = 1 - Reset Totalizer = 2 - Unlatch Output = 3 - Reset and Unlatch

Serial Commands (continued)

L25 a	A	Load Totalizer D.P. Location Where a = 0 - No Dec. Pt. = 1 - XXXXX.X = 2 - XXXX.XX = 3 - XXX.XXX = 4 - XX.XXXX = 5 - X.XXXXX
Q25	A25a	Query Totalizer D.P. Location Where a = 0 - No Dec. Pt. = 1 - XXXXX.X = 2 - XXXX.XX = 3 - XXX.XXX = 4 - XX.XXXX = 5 - X.XXXXX
L26a	A	Load Auto Stop Mode Enable Where a = 0 - No Auto Stop = 1 - Auto Stop Enabled
Q26	A26 a	Query Auto Stop Mode Enable Where a = 0 - No Auto Stop = 1 - Auto Stop Enabled
L31 aa	A	Load Ratemeter Smoothing Where aa = Smoothing Fact. (0.5 - 7.5) (must be .5 sec. resolution)
Q31	A31 aa	Query Ratemeter Smoothing Where aa = Smoothing Factor
L32 a b	A	Load Ratemeter Control Input Where a = Control Input (1 - 5) b = 0 - No Function = 1 - Unlatch Alarms
Q32	A32 a b ...	Query All Ratemeter Control Inputs Where a = Control Input b = 0 - No Function = 1 - Unlatch Alarms
L33 a bbbb	A	Load Ratemeter Output Function Where a = 0 - Timed Outputs bbbb = Low Rate Output Time cccc = High Rate Output Time
or		
L33 a		a = 1 - Outputs Follow
Q33	A33 a bbbb cccc	Query Ratemeter Output Function Where a = 0 - Timed Outputs bbbb = Low Rate Output Time cccc = High Rate Output Time
or		
Q33	A33 a	Where a = 1 - Outputs Follow
L34 a b	A	Load Ratemeter Reset and Stop Keys Where a = Reset Key Function = 0 - No Function = 1 - Unlatch Outputs b = Stop Key Function = 0 - No Function = 1 - Unlatch Outputs

Serial Commands (continued)

Q34	A34 a b	<p>Query Ratemeter Reset and Stop Keys</p> <p>Where a = Reset Key Function = 0 - No Function = 1 - Unlatch Outputs</p> <p>b = Stop Key Function = 0 - No Function = 1 - Unlatch Outputs</p>
L35 a	A	<p>Load Ratemeter D.P. Location</p> <p>Where a = 0 - No Dec. Pt. = 1 - XXXX.X = 2 - XXX.XX = 3 - XX.XXX = 4 - X.XXXX</p>
Q35	A35 a	<p>Query Ratemeter D.P. Location</p> <p>Where a = 0 - No Decimal Point = 1 - XXXX.X = 2 - XXX.XX = 3 - XX.XXX = 4 - X.XXXX</p>
L36 aa	A	<p>Load Low Rate Output Delay Time</p> <p>Where aa = Delay Time (0.0 - 9.9)</p>
Q36	A36 aa	<p>Query Low Rate Output Delay Time</p> <p>Where aa = Delay Time</p>
L37 aa	A	<p>Load Zero Rate Time</p> <p>Where aa = Zero Time (01 - 15)</p>
Q37	A37 aa	<p>Query Zero Rate Time</p> <p>Where aa = Zero Time</p>
L38 aaaa	A	<p>Load Rate Display Header</p> <p>Where aaa = Rate Display Header (Space, Uppercase letters, /, or #)</p>
Q38	A38 aaaa	<p>Query Rate Display Header</p> <p>Where aaaa = Rate Display Header</p>
L39 a	A	<p>Load Rate Lo Output Mode</p> <p>Where a = 0 - Start Enabled = 1 - Continuous</p>
Q39	A39 a	<p>Query Rate Lo Output Mode</p> <p>Where a = 0 - Start Enabled = 1 - Continuous</p>
L41 a	A	<p>Load Key 8 Function</p> <p>Where a = 0 - Prewarn Mode = 1 - Setpoint Mode</p>
Q41	A41 a	<p>Query Key 8 Function</p> <p>Where a = 0 - Prewarn Mode = 1 - Setpoint Mode</p>
L42 a	A	<p>Load Control Display Mode</p> <p>Where a = 0 - Display Actual = 1 - Display Remaining</p>
Q42	A42 a	<p>Query Control Display Mode</p> <p>Where a = 0 - Display Actual = 1 - Display Remaining</p>

Serial Commands (continued)

L43 a b	A	<p>Load Batch Control Input</p> <p>Where a = Control Input (1-5)</p> <p style="margin-left: 20px;">b = 0 - No Function</p> <p style="margin-left: 20px;">= 1 - Reset Batch Counter</p> <p style="margin-left: 20px;">= 2 - Start</p> <p style="margin-left: 20px;">= 3 - Reset and Start</p> <p style="margin-left: 20px;">= 4 - Stop</p> <p style="margin-left: 20px;">= 5 - Unlatch Overrun Alarm</p> <p style="margin-left: 20px;">= 6 - Jog</p>
Q43	A43 a b ...	<p>Query All Batch Control Inputs</p> <p>Where a = Control Input</p> <p style="margin-left: 20px;">b = 0 - No Function</p> <p style="margin-left: 20px;">= 1 - Reset Batch Counter</p> <p style="margin-left: 20px;">= 2 - Start</p> <p style="margin-left: 20px;">= 3 - Reset and Start</p> <p style="margin-left: 20px;">= 4 - Stop</p> <p style="margin-left: 20px;">= 5 - Unlatch Overrun Alarm</p> <p style="margin-left: 20px;">= 6 - Jog</p>
L44 a b c	A	<p>Load Batch Reset, Start and Stop Keys</p> <p>Where a = Reset Key Function</p> <p style="margin-left: 20px;">= 0 - No Function</p> <p style="margin-left: 20px;">= 1 - Reset Batch Counter</p> <p style="margin-left: 20px;">= 2 - Unlatch Overrun Alarm</p> <p style="margin-left: 20px;">= 3 - Reset and Unlatch</p> <p style="margin-left: 20px;">b = Start Key Function</p> <p style="margin-left: 40px;">= 0 - Disabled</p> <p style="margin-left: 40px;">= 1 - Only Start</p> <p style="margin-left: 40px;">= 2 - Reset and Start</p> <p style="margin-left: 20px;">c = Stop Key Function</p> <p style="margin-left: 40px;">= 0 - Only Stop</p> <p style="margin-left: 40px;">= 1 - Stop and Unlatch Alarm</p>
Q44	A44 a b c	<p>Query Batch Reset, Start and Stop Keys</p> <p>Where a = Reset Key Function</p> <p style="margin-left: 20px;">= 0 - No Function</p> <p style="margin-left: 20px;">= 1 - Reset Batch Counter</p> <p style="margin-left: 20px;">= 2 - Unlatch Overrun Alarm</p> <p style="margin-left: 20px;">= 3 - Reset and Unlatch</p> <p style="margin-left: 20px;">b = Start Key Function</p> <p style="margin-left: 40px;">= 0 - Disabled</p> <p style="margin-left: 40px;">= 1 - Only Start</p> <p style="margin-left: 40px;">= 2 - Reset and Start</p> <p style="margin-left: 20px;">c = Stop Key Function</p> <p style="margin-left: 40px;">= 0 - Only Stop</p> <p style="margin-left: 40px;">= 1 - Stop and Unlatch Alarm</p>
L45 a	A	<p>Load Batch D. P. Location</p> <p>Where a = 0 - No Dec. Pt.</p> <p style="margin-left: 20px;">= 1 - XXXXX.X</p> <p style="margin-left: 20px;">= 2 - XXXX.XX</p> <p style="margin-left: 20px;">= 3 - XXX.XXX</p> <p style="margin-left: 20px;">= 4 - XX.XXXX</p> <p style="margin-left: 20px;">= 5 - X.XXXXX</p>
Q45	A45 a	<p>Query Batch D.P. Location</p> <p>Where a = 0 - No Dec. Pt.</p> <p style="margin-left: 20px;">= 1 - XXXXX.X</p> <p style="margin-left: 20px;">= 2 - XXXX.XX</p> <p style="margin-left: 20px;">= 3 - XXX.XXX</p> <p style="margin-left: 20px;">= 4 - XX.XXXX</p> <p style="margin-left: 20px;">= 5 - X.XXXXX</p>

Serial Commands (continued)

L46 a	A	Load Batch Auto Recycle Mode Where a = 0 - No Auto Recycle
or		
L46 a bb	A	Load Batch Auto Recycle Mode Where a = 1 - Auto Recycle b = Recycle Delay Time (0.0 - 9.9)
Q46	A46 a	Query Batch Auto Recycle Mode Where a = 0 - No Auto Recycle
or		
Q46	A46 a bb	Query Batch Auto Recycle Mode Where a = 1 - Auto Recycle b = Recycle Delay Time
L47 aaaaaa	A	Load Batch Offset Where aaaaaa = Offset
Q47	A47 aaaaaa	Query Batch Offset Where aaaaaa = Offset
L48 aaaaaa	A	Load Batch Overrun Where aaaaaa = Overrun
Q48	A48 aaaaaa	Query Batch Overrun Where aaaaaa = Overrun
L49 a bbbb	A	Load Over/Quad Error Selection/Time Where a = 0 - Overrun Setpoint Output = 1 - Quad Error Output bbbb = Output Time (00.00 - 99.99)
Q49	A49 a bbbb	Query Over/Quad Error Selection/Time Where a = 0 - Overrun Setpoint Output = 1 - Quad Error Output bbbb = Output Time (00.00 - 99.99)
L51 a b	A	Load Key Lock (Keys 2, 4, 5, 7, 8 and 9) Where a = Key Number (2, 4, 5, 7, 8, 9) b = 0 - Unlocked = 1 - Locked
or		
L51 7 b cccccc	A	Load Key Limit (Key 7) Where b = 2 - Limited ccccc = Limit Value
Q51	A51 a b (c)...	Query Key Lock (Keys 2, 4, 5, 7, 8 and 9) Where a = Key Number (2, 4, 5, 7, 8, 9) b = 0 - Unlocked = 1 - Locked = 2 - Limited (Key 7 Only) c = Limit Value (Key 7 only if so programmed)
L55 a	A	Load Count Mode Where a = 0 - 7 = 0 - Count w/Inh Fast = 1 - Count w/Inh Med = 2 - Count w/Inh Slow = 3 - Count w/Det Fast = 4 - Count w/Det Med = 5 - Count w/Det Slow = 6 - Count Quad Fast = 7 - Count Quad w/Det Fast

Serial Commands (continued)

Q55	A55 a	Query Count Mode Where a = 0 - 7 = 0 - Count w/Inh Fast = 1 - Count w/Inh Med = 2 - Count w/Inh Slow = 3 - Count w/Det Fast = 4 - Count w/Det Med = 5 - Count w/Det Slow = 6 - Count Quad Fast = 7 - Count Quad w/Det Fast
L56 a	A	Load Transistor 3 & 4 Select Where a = 0 - Trip / B Size = 1 - Rate Lo/Hi
Q56	A56 a	Query Transistor 3 & 4 Select Where a = 0 - Trip / B Size = 1 - Rate Lo/Hi
L57 a b	A	Load Program Inhibit Control Input Where a = Control Input (1-5) b = 0 - Disabled (not Programmed) = 1 - Enabled
Q57	A a b	Query Program Inhibit Control Input Where a = Control Input (1-5) b = 0 - Disabled (not programmed) = 1 - Enabled

Example: A57 1020314050 --> Control Input 3 is programmed for Program Inhibit

I/O Terminal Description

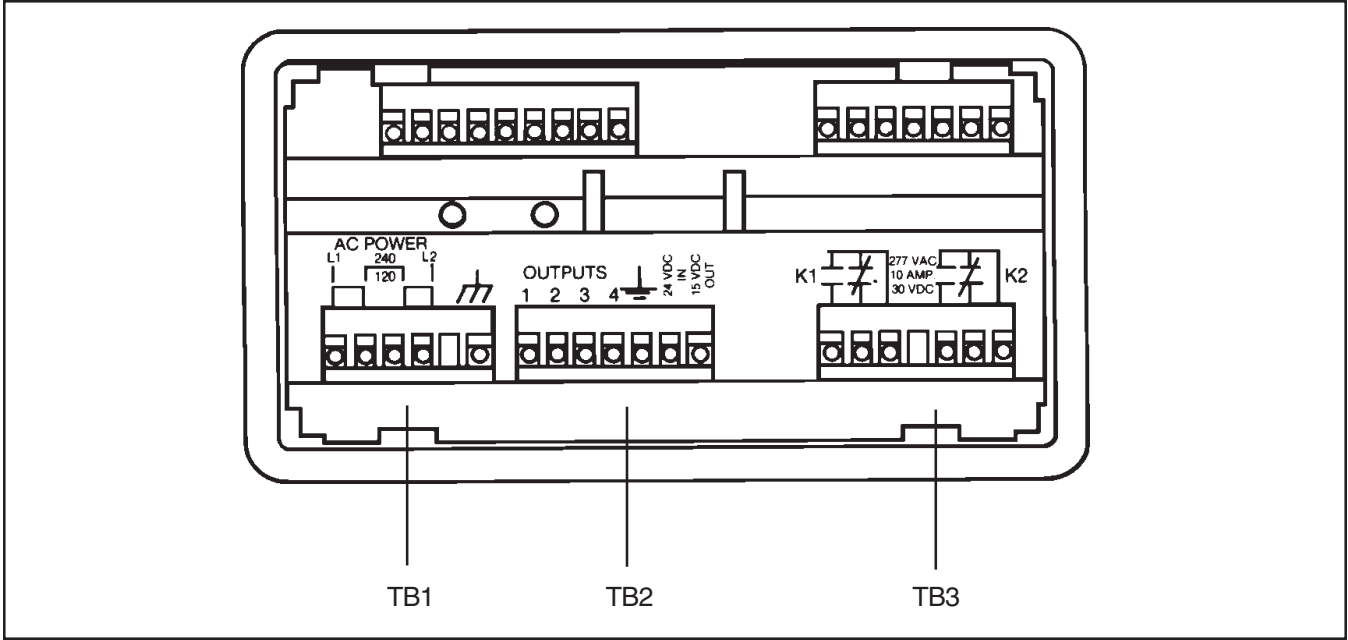

TB1 AC Power Input

- L1 Terminal connection for 120/240 Vac L1 lead.
- L2 Terminal connection for 120/240 Vac N or L2 lead.
- Chassis ground. This terminal should be connected to earth ground.

Note: The power supply wiring requires that jumpers be connected across the terminal connections as indicated on the back panel. For a 240 Vac power supply, the center two terminals need to be jumpered. For a 120 Vac supply, the two outside terminals both need to be jumpered. Install a 0.2 Amp Slow Blow fuse at L1 and L2 if 120 Vac is used and a 0.1 Amp fuse if 240 Vac is used.

TB2 Transistor Outputs, 24 Vdc Power

- OUTPUT 1 Totalizer Scaled Pulse/Totalizer Setpoint/Quadrature Error
- OUTPUT 2 Batch Overrun/Quadrature Error Output
- OUTPUT 3 Rate Lo Alarm/Batch First Trip Output
- OUTPUT 4 Rate Hi Alarm/Batch Final Trip Output
- DC common. When unit is powered by dc, connect minus side of 18-27 Vdc power supply to this terminal. When unit supplies 15 Vdc power for accessories, connect accessory dc common to this terminal.

- 24 Vdc IN When unit is powered by dc, connect plus side of 18-27 Vdc power supply to this terminal. Install a 0.5 amp Slow Blow fuse.
- 15 Vdc OUT Plus 15 Vdc accessory power. Connect this terminal to the accessory plus 15 Vdc input.

TB3 K1/K2 Relay Contacts

- K1 Terminals are symbolically-designated by ~ ac wave form and are normally in the de-energized state. K1 is the first trip or Lo rate set-point relay.
- K2 Terminals are symbolically-designated by ~ ac wave form and are normally in the de-energized state. K2 is the final trip or Hi rate setpoint relay. It is also the jog relay.

Special Precaution

To maintain Class I, Division 2, T4 suitability, be sure the maximum (continuous) current on each SSR does not exceed 2A. Fuse 2A (Slo-Blow) 250V where required.

I/O Terminal Description (continued)

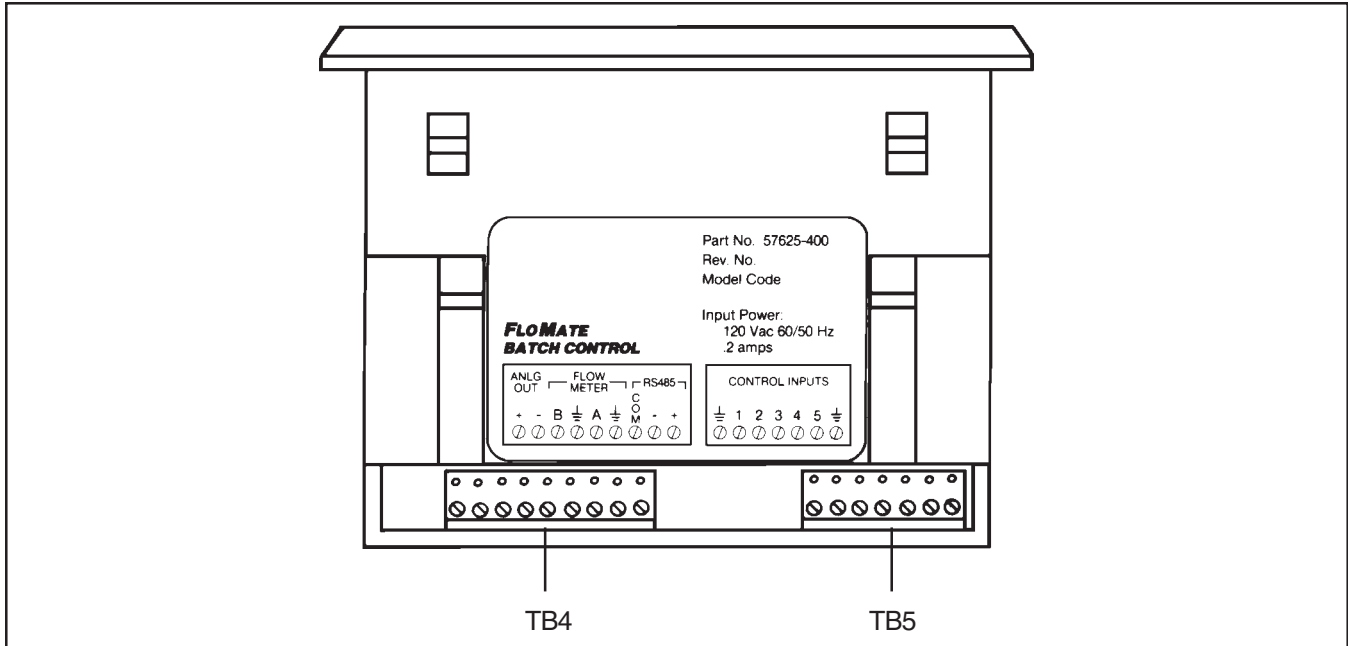

TB4 Analog Output, Flowmeter Input, Communications Output

- ANLNG OUT +** Connect the Analog Output Positive terminal to the Analog Circuit Power Supply Positive or the 15 Vdc Out terminal on TB2. The maximum voltage to be applied to Analog Out is 27 Vdc. The minimum voltage is 12 Vdc + Load Drop @ 20 mA.
- ANLNG OUT -** Connect the Analog Output Negative terminal to the Analog Load Positive terminal. The 4-20 mA signal with respect to common is put out at the Analog Out terminal.
- FLOWMETER B** This is the Inhibit input when the Count mode selected is Count with Inhibit, or it is the Direction input when Count with Direction is selected. This terminal is one of the count inputs when the Count mode selected is Quadrature.
- FLOWMETER \perp** DC common is the reference level for the flowmeter and control inputs (input active when connected to dc common) and transistor outputs conduct to dc common when in the On state. DC common is not connected to chassis ground.
- FLOWMETER A** This terminal is the Count input when the Count mode selected is Count with Inhibit or Count with

Direction. This terminal is one of the Count inputs when the Count mode selected is Quadrature.

Note: Flowmeter inputs require current sinking device such as a contact closure to ground or an NPN transistor to ground.

- RS-485 COM** Communications Common terminal. Connected to dc common by a 100 Ω internal resistor.
- RS-485-/RS-485+** Communications differential signal input/output.

TB5 Control Inputs

- Control Inputs \perp** DC Common. Control inputs are active when connected to dc common.
- Control Inputs 1, 2, 3, 4, 5** Programmable inputs which may be assigned to various functions as explained in the Program mode.

Rear Terminal Retainer Bracket

Rear terminal retainer bracket must be in place (see Terminal Retainer Bracket diagram page) to ensure hazardous incendiary (make/break) energy is not released under normal conditions.

Rear terminal wire hook-up and modification can be performed (under non-hazardous conditions) by removing this bracket. Loosen the two bracket screws so that the two-piece bracket assembly may be separated by about 3 mm (1/8"). Lift the top section of the bracket over TB4 and TB5.

Wiring Diagrams

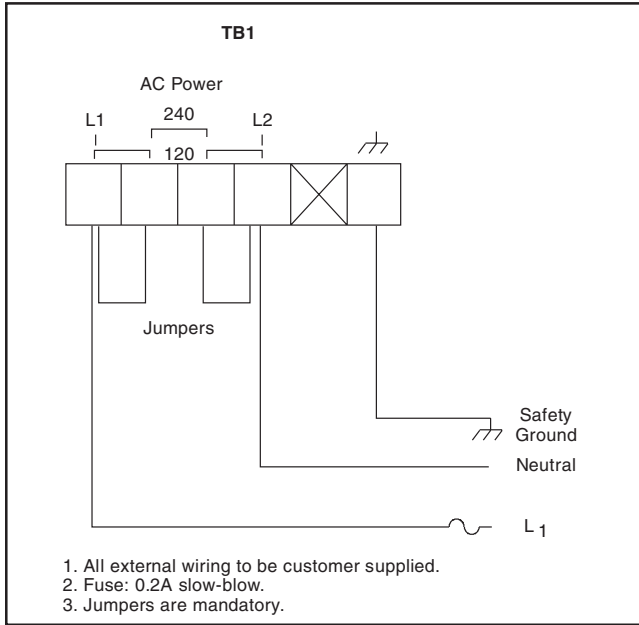

120 Vac Power In

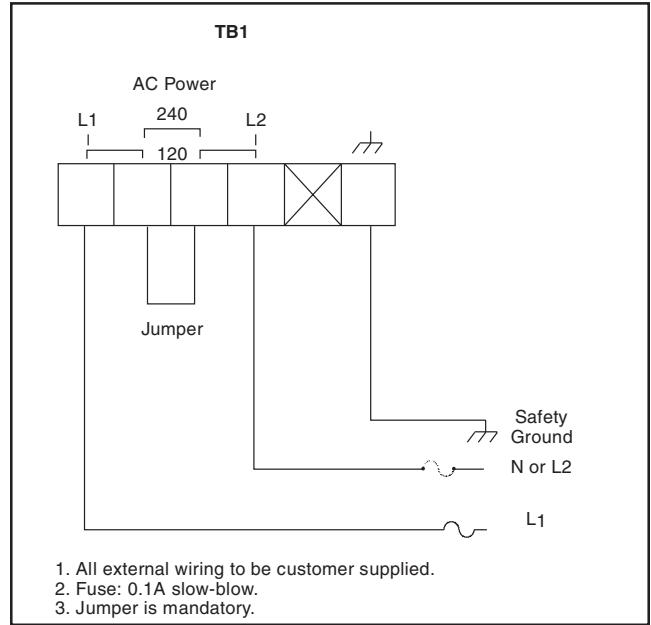

240 Vac Power In

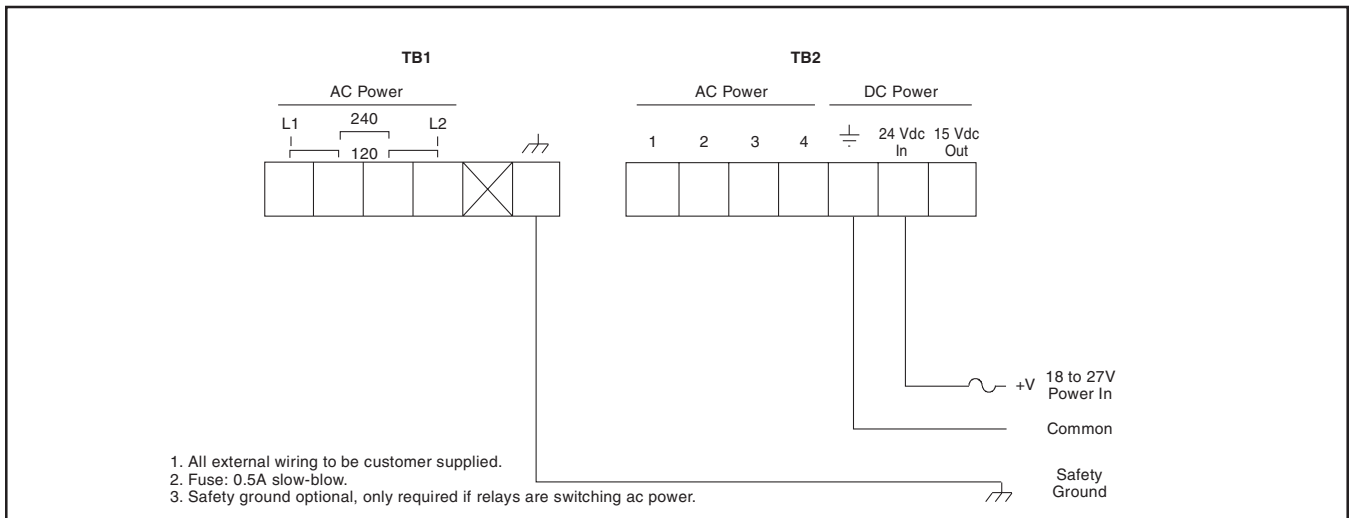

DC Power In

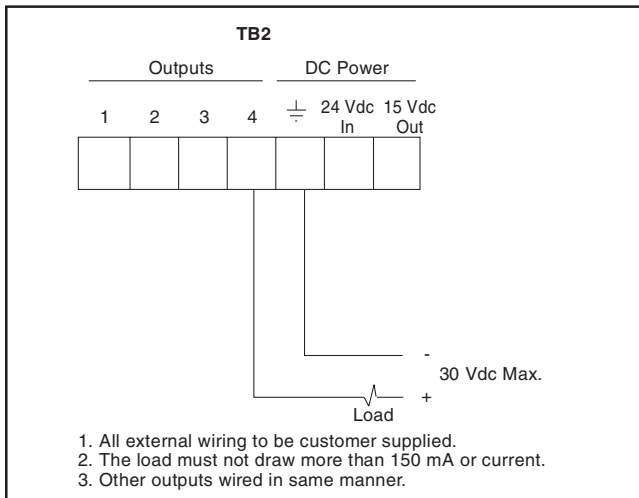

Transistor Outputs

Wiring Diagrams (continued)

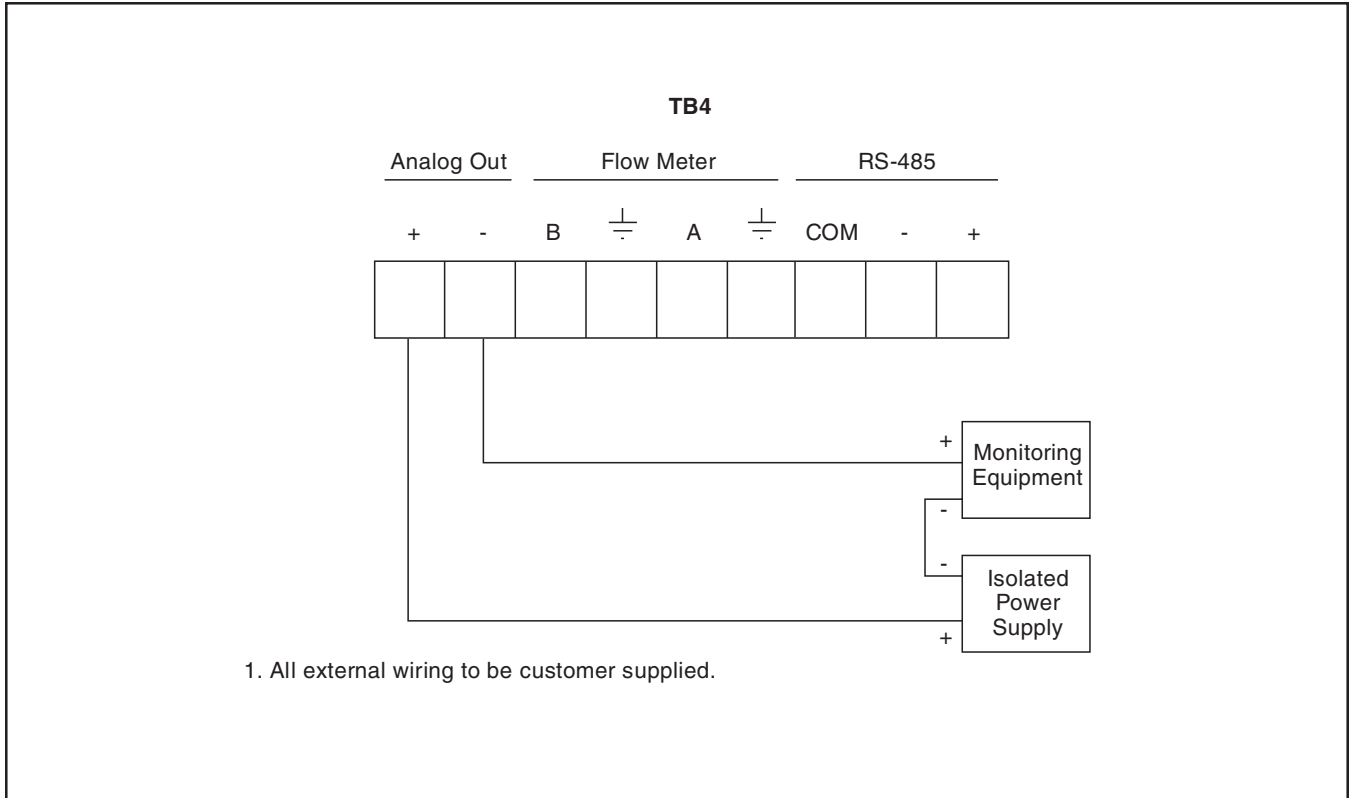

Analog Rate Output (Isolated)

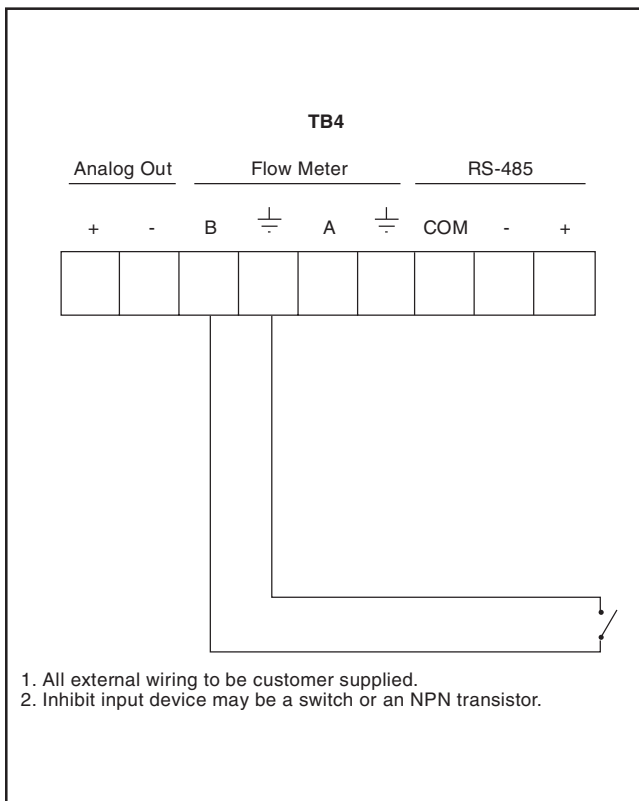

Pulse Inhibit Input

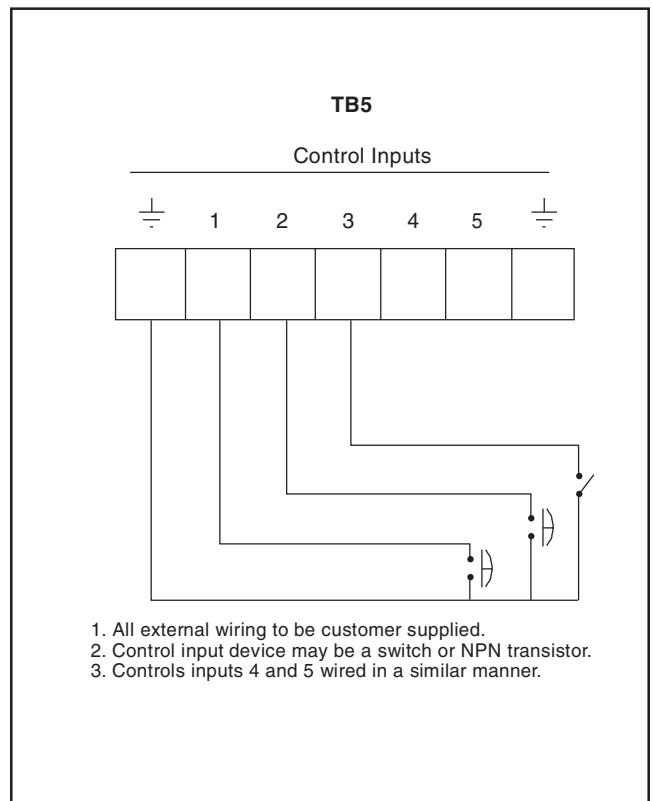

Control Inputs

Wiring Diagrams (continued)

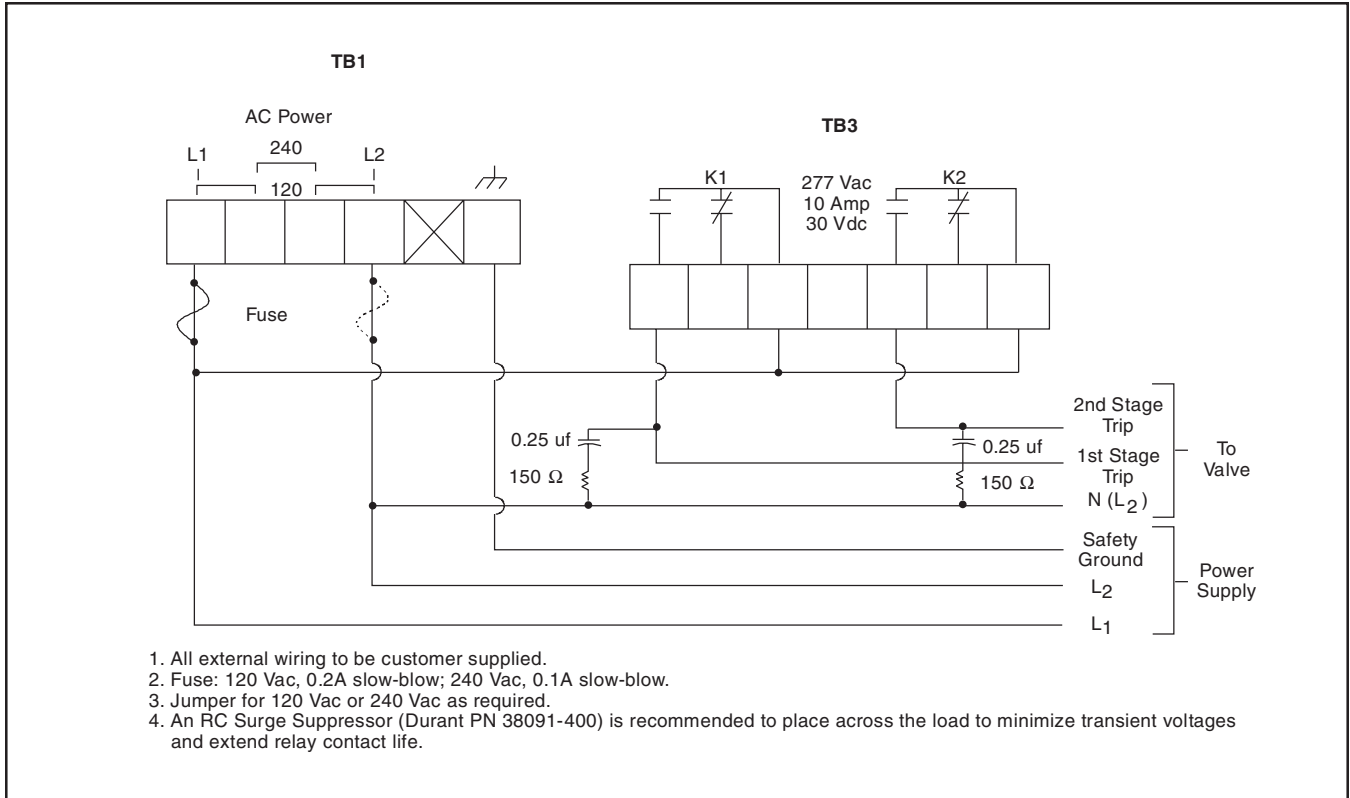

296 Valve

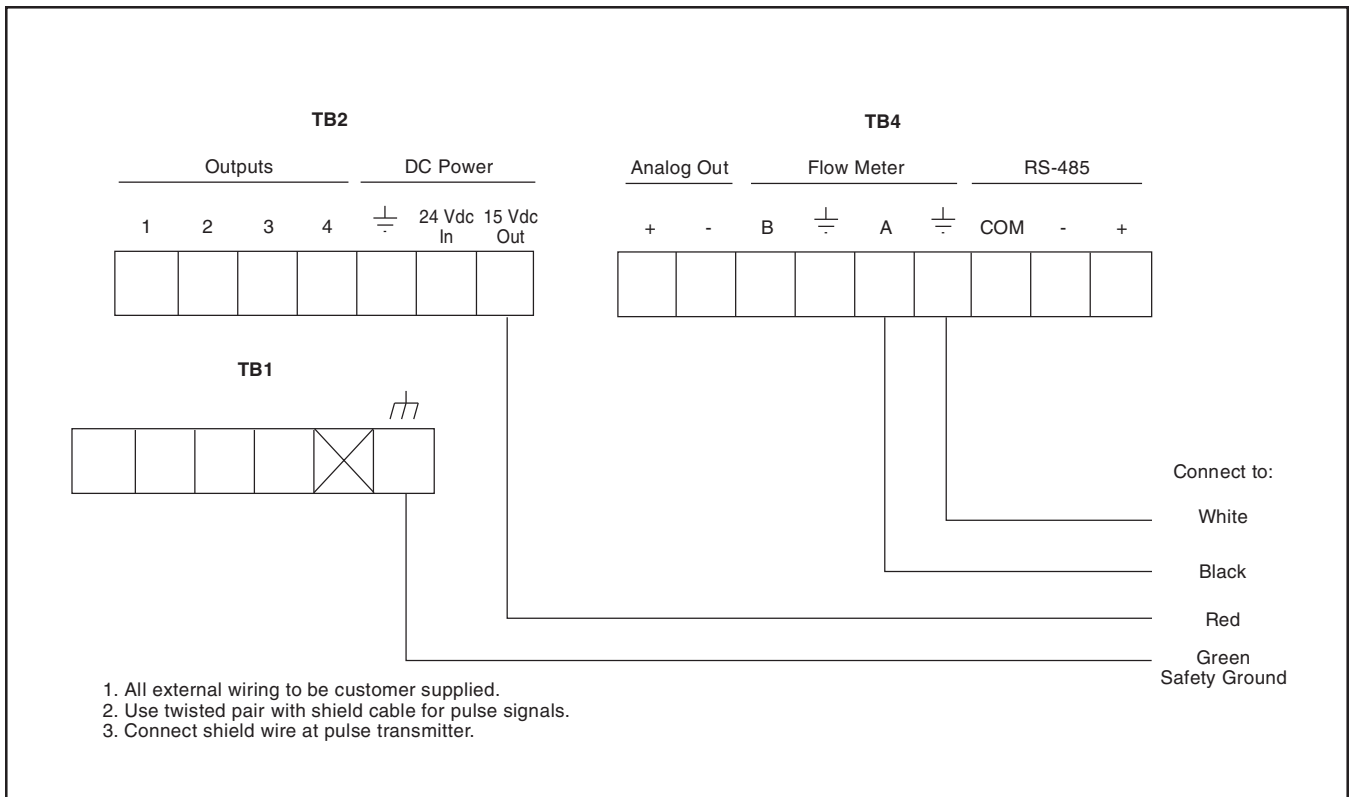

PEXP Pulse Transmitter

Wiring Diagrams (continued)

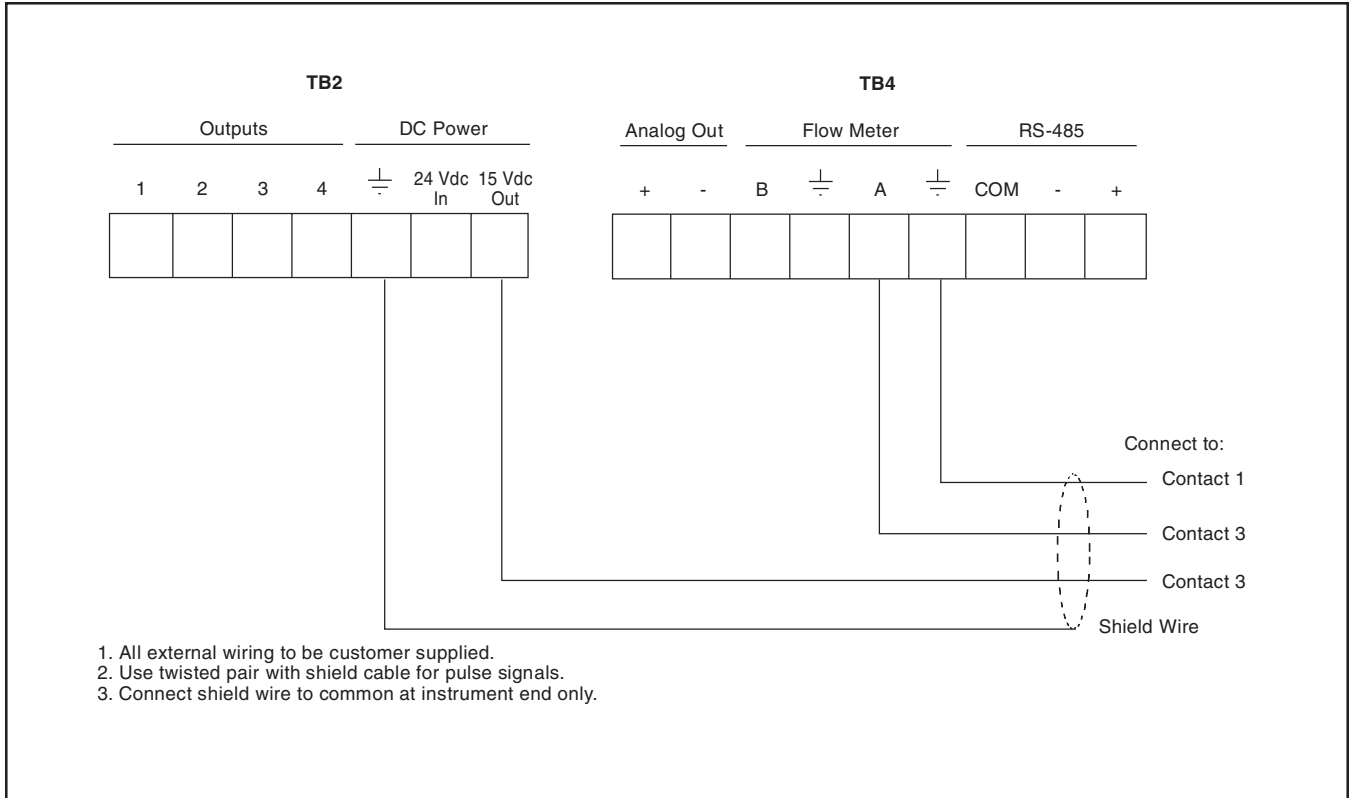

PA-4 Preamplifier and Type D Transmitter

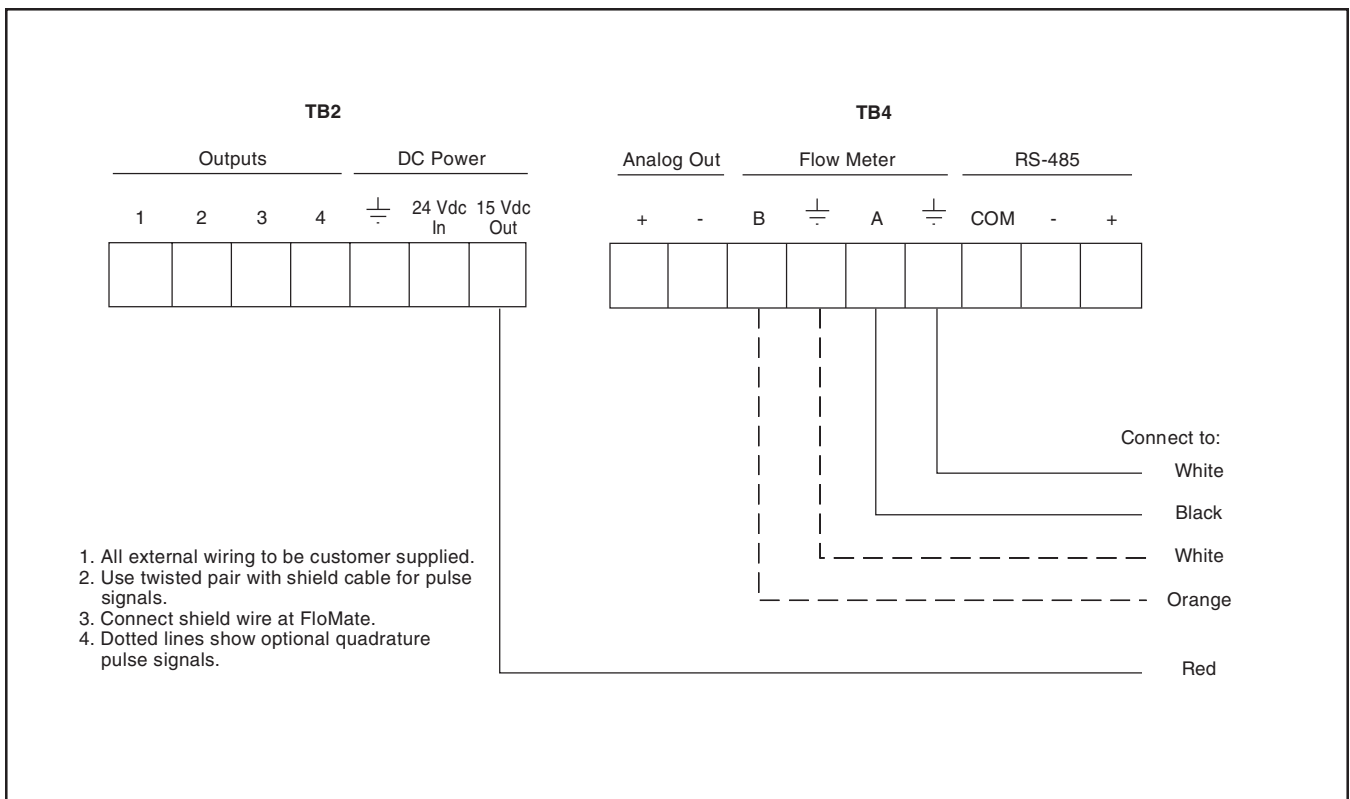

PD Meter Counter Transmitter, Model HR-LNC

Wiring Diagrams (continued)

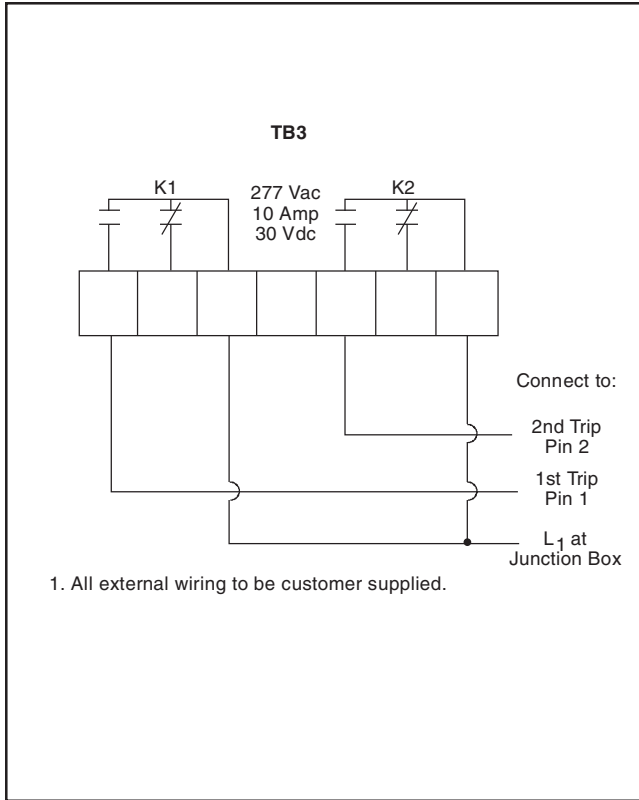

SS1 Controller

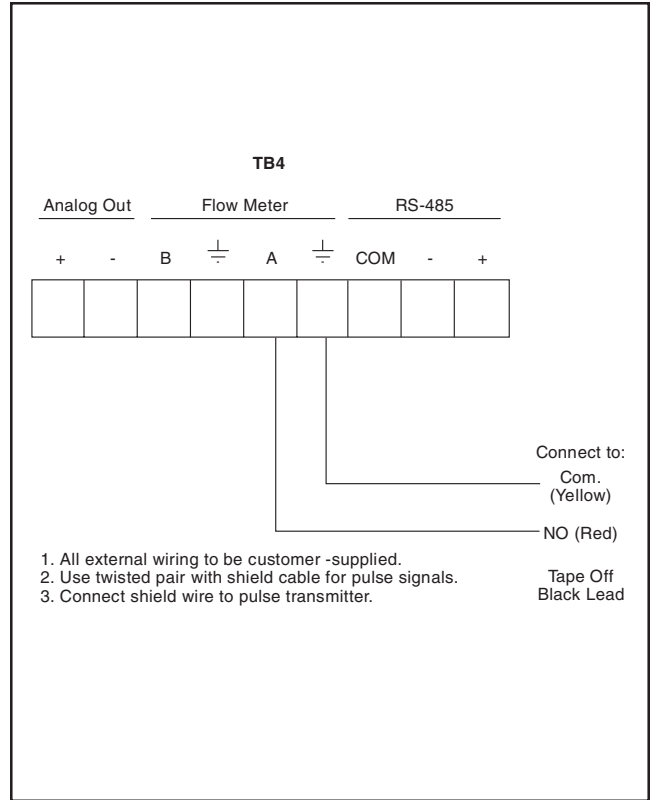

Model E Pulse Transmitter

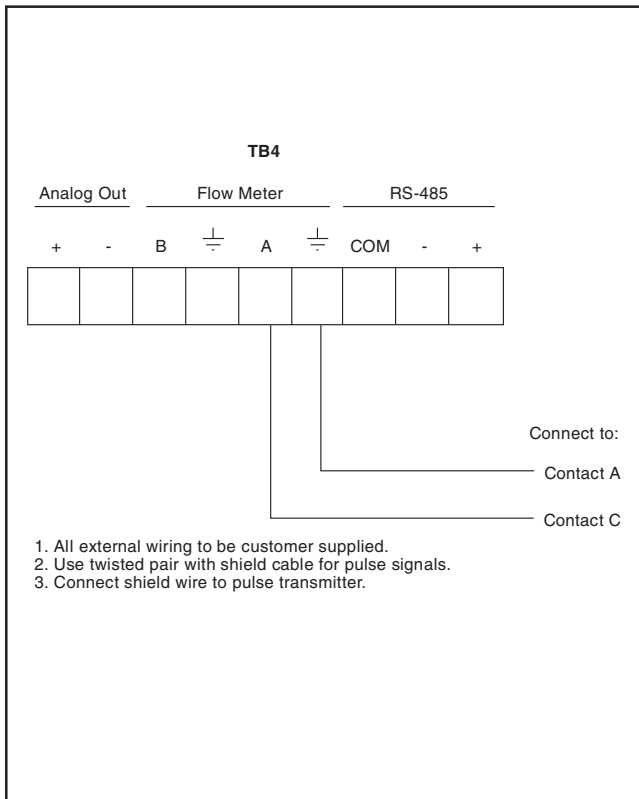

PE-P Portable Pulse Transmitter

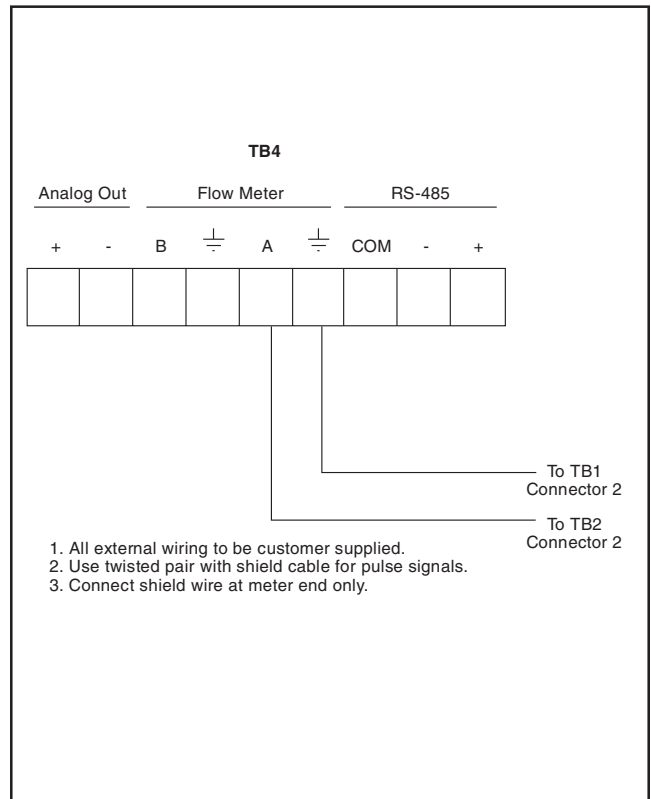

MMT-25

Wiring Diagrams (continued)

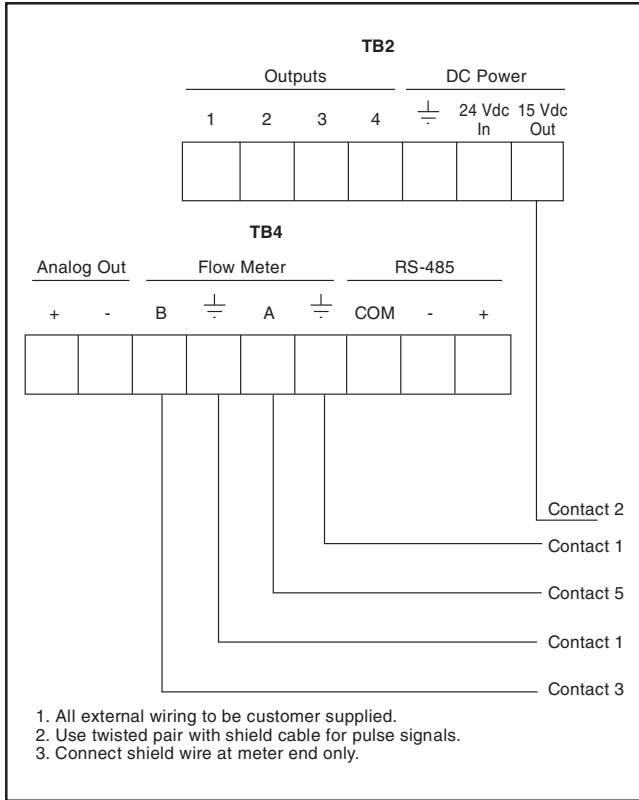

Model PPS Transmitter

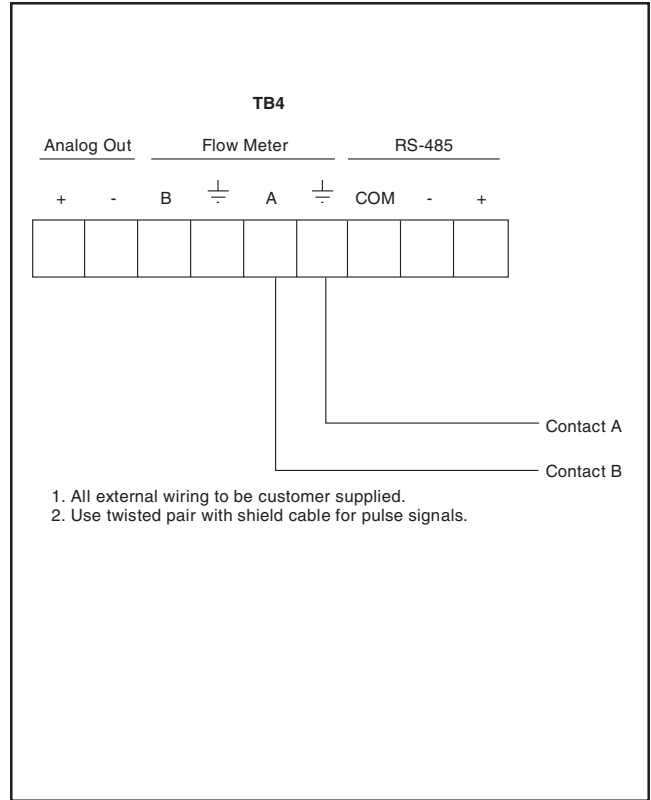

PD Meter Counter Transmitter, Model LNC

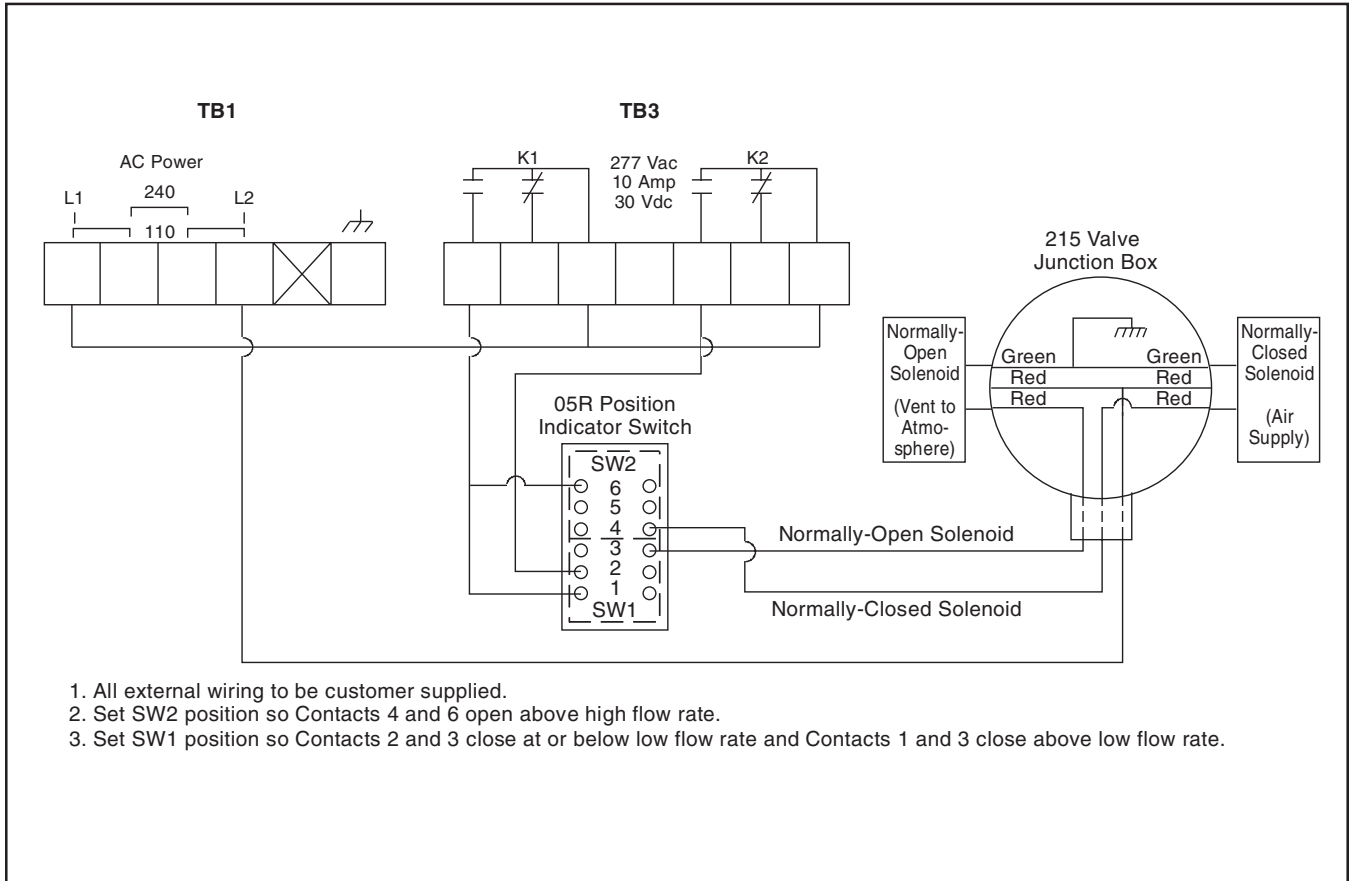

215 Valve with 05R Option for Two-Stage Shut-Down

Wiring Diagrams (continued)

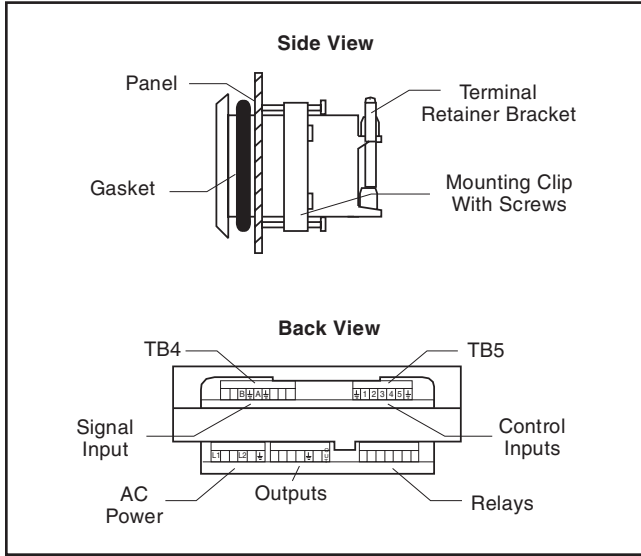

Terminal Retainer Bracket

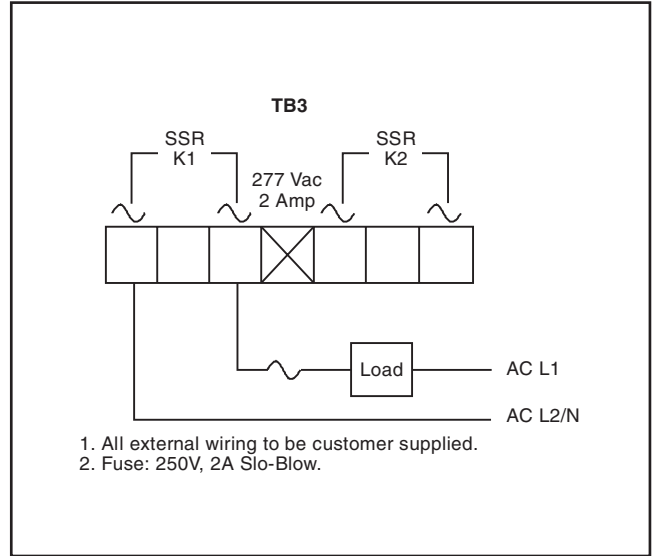

K6FBP3 K1 and K2 Solid-State Relay Outputs

1. All external wiring to be customer supplied.
2. Fuse: 250V, 2A Slo-Blow.

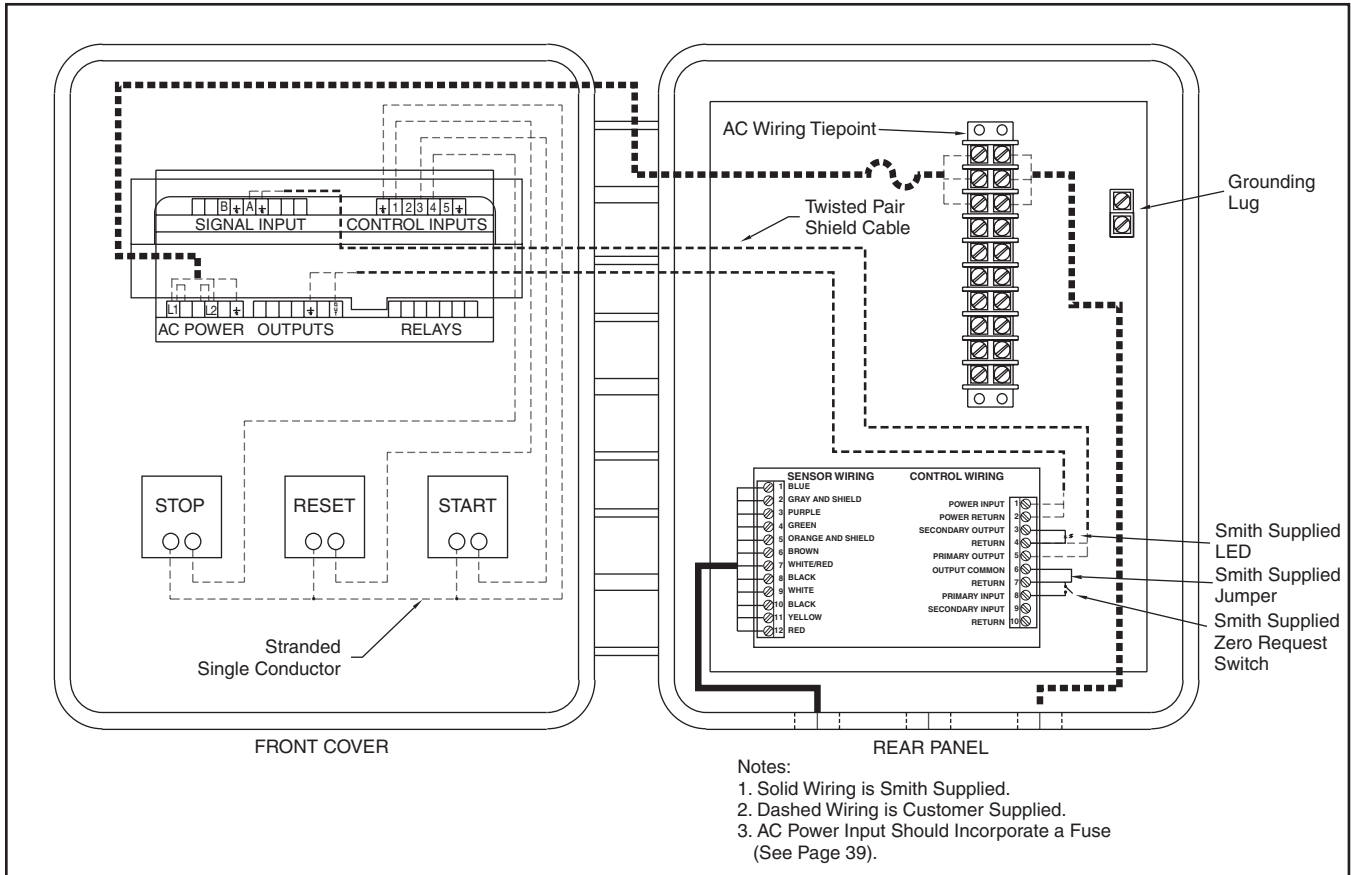

- Notes:
1. Solid Wiring is Smith Supplied.
 2. Dashed Wiring is Customer Supplied.
 3. AC Power Input Should Incorporate a Fuse (See Page 39).

Typical Wiring Configuration for a FloMate to a Micro-Pak

Dimensions

Inches (mm)

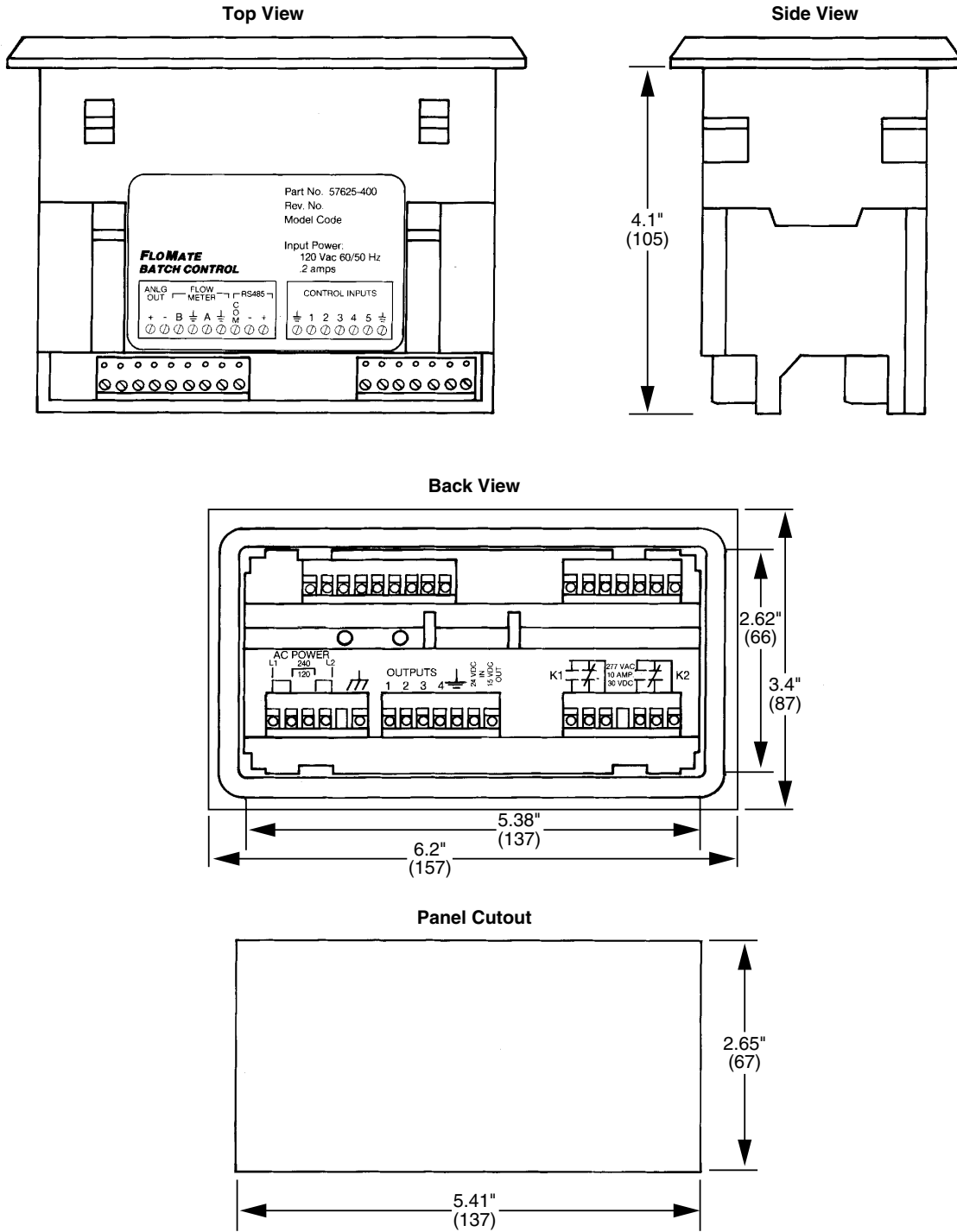

Note: Dimensions - inches to the nearest tenth (millimeters to the nearest whole mm), each independently dimensioned from respective engineering drawings.

Notes

Revisions included in MN09033 Issue/Rev. 0.1 (12/01):
Added Caution and Disclaimer Statement.
Included MN09033LU1 Update.

The specifications contained herein are subject to change without notice and any user of said specifications should verify from the manufacturer that the specifications are currently in effect. Otherwise, the manufacturer assumes no responsibility for the use of specifications which may have been changed and are no longer in effect.

Headquarters:

1803 Gears Road, Houston, TX 77067 USA, Phone: 281/260-2190, Fax: 281/260-2191

Gas Measurement Products:

Erie, PA USA Phone 814/898-5000
Thetford, England Phone (44) 1842-82-2900
Kongsberg, Norway Phone (47) 32/286-700
Buenos Aires, Argentina Phone 54 (11) 4312-4736

Integrated Measurement Systems:

Corpus Christi, TX USA Phone 361/289-3400
Kongsberg, Norway Phone (47) 32/286-700
San Juan, Puerto Rico Phone 787/274-3760
United Arab Emirates, Dubai Phone 971 +4/331-3646

Liquid Measurement Products:

Erie, PA USA Phone 814/898-5000
Los Angeles, CA USA Phone 661/702-8660
Slough, England Phone (44) 1753-57-1515
Ellerbek, Germany Phone (49) 4101-3040
Barcelona, Spain Phone (34) 93/201-0989
Moscow, Russia Phone (7) 495/564-8705
Melbourne, Australia Phone (61) 3/9807-2818

Beijing, China Phone (86) 10/6500-2251
Singapore Phone (65) 6861-3011
Chennai, India Phone (91) 44/450-4400

Visit our website at www.fmctechnologies.com