



Contents

| | |
|--|--------|
| Section 1 — Introduction | Page 2 |
| Section 2 — Installation | Page 3 |
| Receipt of Equipment | Page 3 |
| Mounting | Page 3 |
| Conduit Installation | Page 3 |
| Dimensions, Figure 1 | Page 3 |
| Electrical Connections | Page 4 |
| Wiring, Figure 2 | Page 5 |
| Section 3 — Adjustments, OPV (Option) | Page 6 |
| Section 4 — Reassembly and Ticket Tray Adjustment | Page 7 |
| Section 5 — Operation | Page 8 |
| Section 6 — Related Publications | Page 8 |

Section 1 — Introduction

The Smith Meter™ Load Printer is an electromechanical ticket printer capable of accumulating and printing pulses received from a transmitting device. The Load Printer requires electrical power either at 110 Vac or 220 Vac $\pm 15\%$. The ticket printer may be either accumulative or zero start. Further details are listed in the Specification Bulletin and Installation Manual.

The Load Printer is impervious to most environmental fluctuations and provides service over a wide range of operating conditions. The Load Printer is contained within an explosion proof housing meeting the following requirements:

- UL Listed and CSA certified for use in Class I, Groups C & D, Division 1 and 2.

The unit also meets NEMA IV weatherproofing. The Smith Meter Load Printer will perform at temperatures down to -40°F (-40°C) without the need for a supplementary heater/thermostat system.

This manual contains information for servicing a properly installed Load Printer. Read and understand the contents of this manual before attempting any service procedure.

Section 2 — Installation

Receipt of Equipment

When the equipment is received, the outside packing case should be checked immediately for any shipping damage. If the packing case has been damaged, the local carrier should be notified at once regarding his liability. Carefully remove the unit from its packing case and inspect for damaged or missing parts.

If damage has occurred during shipment or parts are missing, a written report should be submitted to the Customer Service Department, FMC Technologies Measurement Solutions, Inc., Erie, Pennsylvania 16514.

Prior to installation, the unit should be stored in its original packing case and protected from adverse weather conditions and abuse.

Mounting

The installation kit provided with each unit includes four (4) mounting bolts (1/2 - 13) with washers. Mounting hole dimensions can be found on Figure 1. The Load Printer may be mounted using the holes located on the bottom or the holes located on the back of the housing.

Conduit Installation

The Smith Meter Load Printer has two 1/2" NPT openings for conduit connections (Figure 1). The entrance nearest the front is for dc and signal cables only. The entrance nearest the rear is for ac wires only.

It is recommended that explosion proof devices be installed as prescribed by The National Electrical Code, Articles 500-503 and 510-517, or the local equivalent using approved wire and cable.

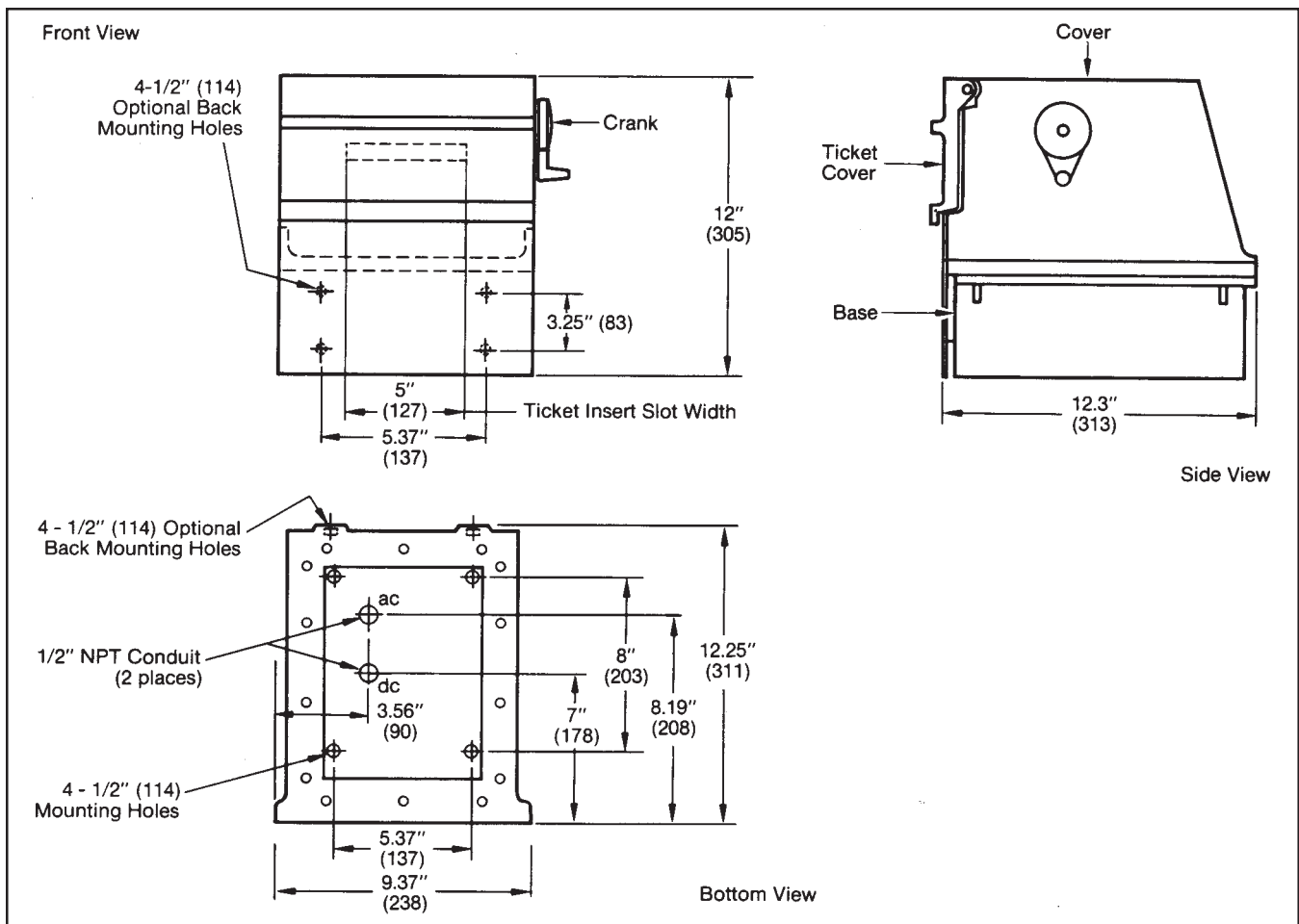

Figure 1 – Load Printer Dimensions

Section 2 — Installation (continued)

Electrical Connections

It is necessary to gain access to the Terminal Strip, before any electrical connections are made, as follows:

1. Remove the screw holding the crank handle in place.
2. Remove the crank handle by grasping it firmly and pulling it straight out.
3. Remove the four bolts securing the cover (two bolts at rear, two bolts in front under the lip of the Ticket Cover).
4. Lift off cover. This step provides access to the printer.
5. Remove the seven (7) socket head screws that secure the cover to the base.
6. Carefully lift the printer upwards to expose the wiring harness and the pair of wires from the Ticket Tray Switch.

Caution:

Lift Printer Assembly carefully at the front to permit access to Stepper Motor Wiring Harness Plug. Disconnect plug located on Ticket Printer Board by squeezing the locking tabs on the top and bottom of the plug.

7. Disconnect wires to the Ticket Tray Switch to gain access to the Load Printer.

Caution:

Record where the wires are terminated on the Ticket Tray Switch enabling correct termination when re-assembling.

8. **AC Power Connections.** Connect the ac electrical power input to the Terminal Strip, Terminal Numbers 7 and 10 (Figure 2). Use #14 AWG minimum stranded. AC power connections include Terminals 5 through 10. Use conduit entrance nearest front.

Note: Either 110 Vac or 220 Vac power inputs are possible.

- a. **For 110 Vac** - Two jumpers are used. One jumper must connect Terminal Number 7 to Terminal Number 8. The second jumper must connect Terminal Number 10 to Terminal Number 9 (Figure 2).

- b. For **220 Vac** - Only one jumper is used and connects Terminal Number 8 to Terminal Number 9.

8. **DC and Signal Connections.** Reference Terminals, 1, 2, 3, 4, 11, and 12. Use signal cable, #18 AWG, stranded, insulated, twisted pairs with 100% shield and external insulation.

| Distance* | Wire/Size | |
|--------------------------------|-----------|----------------|
| Up to 2,000 ft. (610 meters) | #20 | Two conductor |
| Up to 3,000 ft. (915 meters) | #18 | insulated |
| Up to 5,000 ft. (1,525 meters) | #16 | shielded cable |

*For distances greater than listed above, contact factory and advise:

- Type of instrument and if capacitive coupled.
- Output frequency at maximum flow rate - pulses/second (Hz).
- Transmission length.
- Input impedance of receiving device.

Use conduit entrance nearest front of the printer.

One cable for each of the following terminal pairs: 1 and 2, 3 and 4, 11 and 12. For Terminals 1 and 2, connect shield to terminal 2. For Terminals 3 and 4, connect shield to Terminal 4. The shield on the other end of these cables should be stripped back and taped.

The shield on cable to Terminals 11 and 12 should be stripped and taped. This shield should terminate at the receiver's instrument ground only, not in the printer.

Note: Never terminate signal cable shielding at both ends as this may cause miscounting of signal pulses caused by ground loops.

10. Complete the other connections as follows (Figure 2):
 - a. Terminals 1 and 2: Connections from pulser.
 - b. Terminals 3 and 4: Optional power connections to output devices.
 - c. Terminals 5 and 6: Connections for tray switch.
 - d. Terminals 11 and 12: (Optional) Selectable Pulse per unit volume connections (OPV Board).
11. **Connect the earth ground wire to the ground lug located inside the Load Printer base.**

Section 2 — Installation (continued)

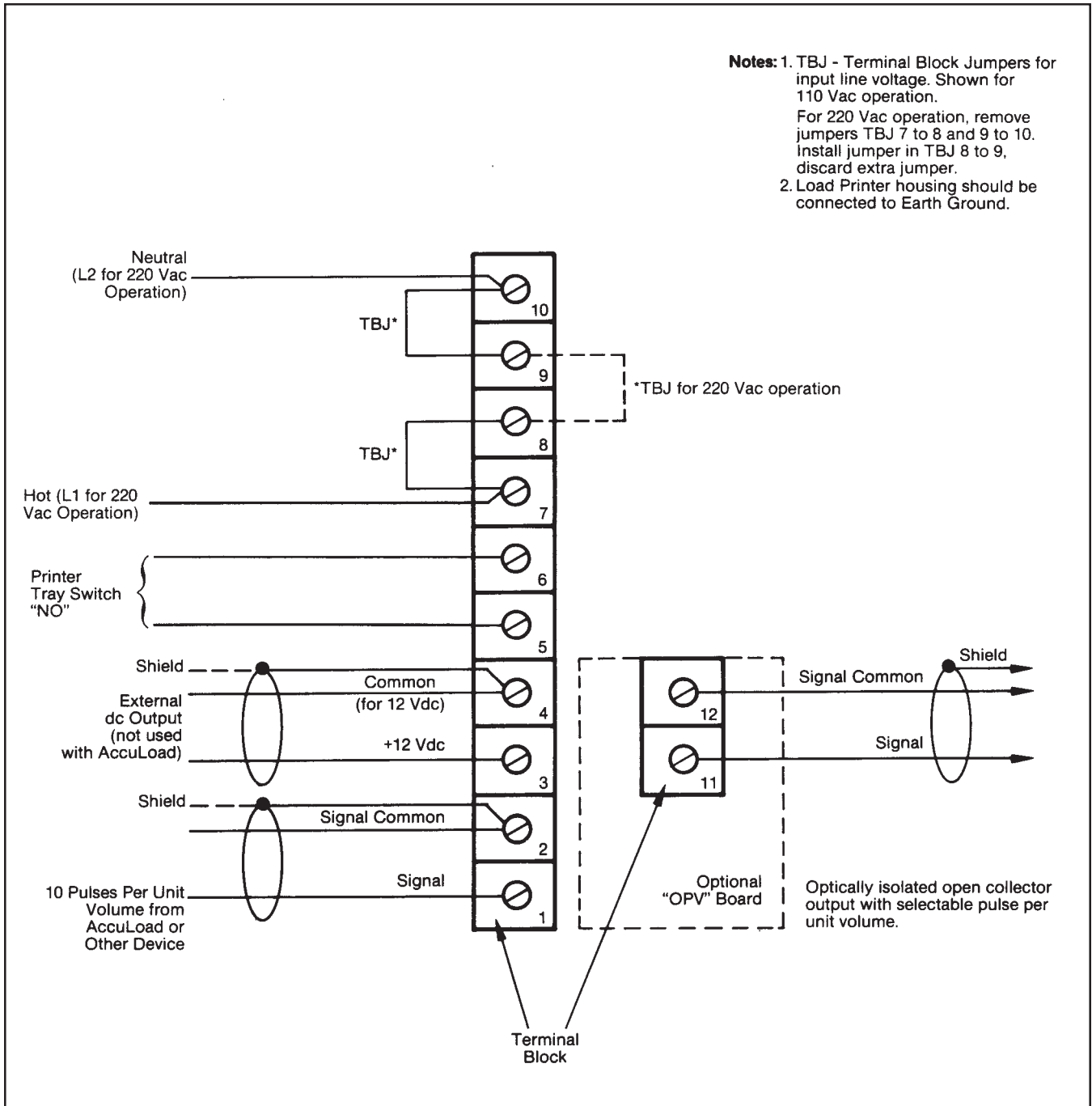

Figure 2 – Load Printer Wiring

Section 3 — Adjustments (OPV Option)

The Load Printer requires 10 pulses in for each unit of registration/print-out. In other words, 100 pulses are required to make one complete revolution of the printer's right-hand wheel. This does not apply to a "fixed" right-hand wheel.

The input resolution to the optional OPV Board is the same as that to the Load Printer as shown by the following diagram:

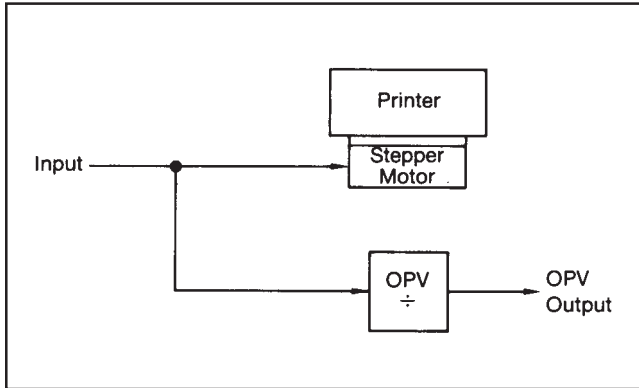
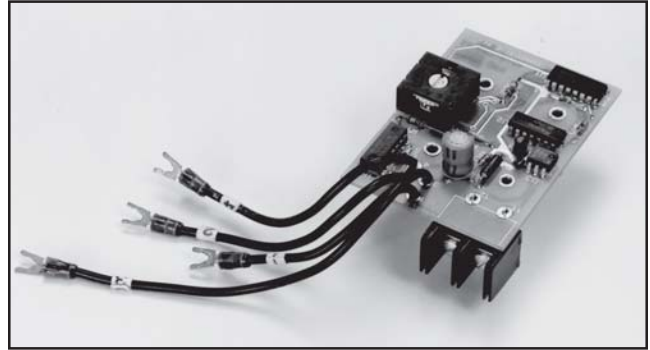

Figure 3

The output from the OPV equals the input, divided by the thumbwheel select number on the OPV Board.

The available select numbers (divides) are 1, 2, 3, 4, 5, 6, 7, 8, 9, 0. Zero is the switch position used for divide by 10.



Section 4 — Reassembly and Ticket Tray Adjustment

1. Reconnect Tray Switch and motor connectors.
2. Replace the base cover with the attached printer.
Avoid pinching the wires between the base cover and base. Secure with the, seven (7) socket head screws previously removed.
3. Check to be sure that the mechanical functions of the printer are working properly. Also, check to be sure that the load tickets can be inserted to ensure printing in the proper spaces on the ticket.
4. Make any necessary adjustments by referring to Figure 4.
 - a. Depth adjustment - loosen screw (A), then position lever (B). Retighten screw (A).
 - b. Width adjustment - remove two screws (C). Position guides (D). Replace screws (C).
5. After all adjustments have been made, replace the Load Printer Cover and secure in place with the four bolts that were previously removed.
6. Replace the crank. Align the slots in the end of the crank shaft with pins in printer shaft.
7. Replace the screw that secures the crank to the shaft.

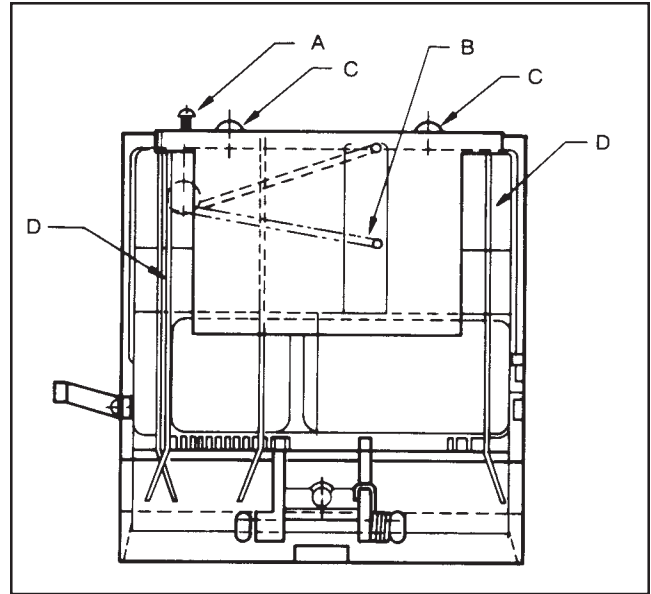

Figure 4

Section 5 – Operation

After the power is on, there are only three basic operations steps, as follows:

1. Lift Ticket Cover, insert ticket into slot, face down, bottom edge first. Be sure to push ticket in as far as it will go. It should protrude to allow removal of ticket.
2. Turn crank forward one complete turn until it stops.
3. After liquid dispensing has been completed, turn the crank as in Step 2. This movement will imprint the ticket and release it for removal.

Section 6 – Related Publications

The following literature can be obtained from FMC Technologies Measurement Solutions, Inc Literature Fulfillment at johno@gohrs.com or online at www.fmctechnologies.com/measurementsolutions. When requesting literature from Literature Fulfillment, please reference the appropriate bulleting number and title.

Load Printer

| | |
|-----------------------------------|------------------|
| Load Printer Specifications | Bulletin SS06004 |
| Load Printer Service | Bulletin MN06011 |

Revisions included in MN06010 Issue/Rev. 0.1 (7/03):
Eliminated CENELEC certification information on Page 2.

The specifications contained herein are subject to change without notice and any user of said specifications should verify from the manufacturer that the specifications are currently in effect. Otherwise, the manufacturer assumes no responsibility for the use of specifications which may have been changed and are no longer in effect.

Headquarters:

1803 Gears Road, Houston, TX 77067 USA, Phone: 281/260-2190, Fax: 281/260-2191

Gas Measurement Products:

Erie, PA USA Phone 814/898-5000
Thetford, England Phone (44) 1842-82-2900
Kongsberg, Norway Phone (47) 32/286-700
Buenos Aires, Argentina Phone 54 (11) 4312-4736

Integrated Measurement Systems:

Corpus Christi, TX USA Phone 361/289-3400
Kongsberg, Norway Phone (47) 32/286-700
San Juan, Puerto Rico Phone 787/274-3760
United Arab Emirates, Dubai Phone 971 +4/331-3646

Liquid Measurement Products:

Erie, PA USA Phone 814/898-5000
Los Angeles, CA USA Phone 661/702-8660
Slough, England Phone (44) 1753-57-1515
Ellerbek, Germany Phone (49) 4101-3040
Barcelona, Spain Phone (34) 93/201-0989
Moscow, Russia Phone (7) 495/564-8705
Melbourne, Australia Phone (61) 3/9807-2818

Beijing, China Phone (86) 10/6500-2251
Singapore Phone (65) 6861-3011
Chennai, India Phone (91) 44/450-4400

Visit our website at www.fmctechnologies.com