

### General

This manual has been prepared to acquaint the installer and serviceman with the operation, adjustment, and maintenance of the basic Smith Meter™ Models 200, 201, 202, and 203 Valves.

The direction of flow is as follows:

For Bare Valves:

Model 202 is fail-closed – flow-over-the-seat.

Model 203 is fail-open – flow-under-the-seat.

For 200 Series Valve Packages:

Model 200 is fail-closed – flow-over-the-seat.

Model 201 is fail-open – flow-under-the-seat.

In addition to the strainer and needle valve, which are incorporated with the Models 200 and 201 valves, additional control functions and accessories must be added to all the valves as required for the application.

These valves are identical in general design, application, and performance. For this reason, except where noted, the valves are treated as one in this manual. All illustrations are of the Model 200 valve unless otherwise indicated. Additional information will accompany this manual when accessories have been added to the basic valve.

### Installation

The Smith Meter™ Diaphragm Valves covered in this manual can be used on loading racks, on pipelines to storage, for the many refinery services, or for industrial applications.

The model number of the valve indicates the mode (fail-open or fail-closed) of the valve. Therefore, when installing the valve in the line, the arrow on the body of the valve must always point in the direction of product flow. The valves may be installed in horizontal or vertical piping.

All control function pilots, accessories, fittings, and tubing required for the application are installed on the valve when it leaves the factory. The installer needs only to place the valve in the line, make the necessary connections, and vent all air from the cover chamber. This is done by pressurizing the system and loosening the highest vent plug in the valve cover until all air is expelled. Valves installed in horizontal lines usually expel all of the air from the cover chamber after just a few full actuations of the valve.

### Adjustments

The adjustments required for smooth and proper operation of these valves will depend upon the control pilots and accessories added to the basic valve. Refer to the appropriate instruction sheet for adjustment procedures pertaining to the specific pilot or control.

The basic Models 200 and 201 diaphragm valves are equipped with a needle valve (see Figure 1), which permits an external adjustment or trimming of the pilot loop. This pilot loop must be adjusted before any of the other adjustments are made.

For the pilot loop (E to F, Figure 1) to efficiently control the main valve with a minimum of pressure drop, it is essential that the orifice of the control pilot has a sufficiently large area to permit the total flow of liquid from the needle valve plus the liquid from the diaphragm chamber to pass through it.

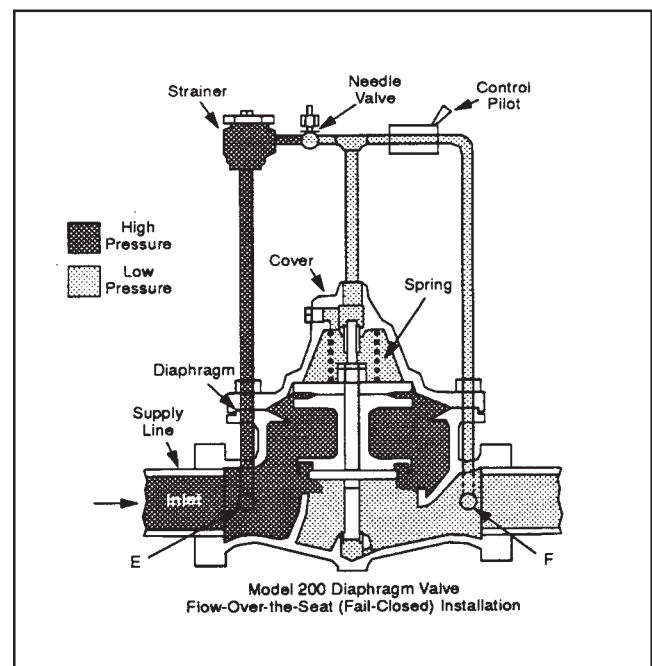

Figure 1

If the needle valve is opened too much, the main valve will only partially open, or perhaps not open at all, resulting in a high pressure drop across the valve. To correct this condition, the needle valve must be throttled to reduce high pressure liquid flow through the pilot loop.

### Operation

A spring holds the valve in the closed position. If flow is over-the-seat (Models 200 and 202), the valve opens when the cover pressure becomes lower than the inlet pressure. As this differential increases, the valve opens wider. Failure of the diaphragm results in a loss of the pressure differential and the valve closes (fail-closed).

When the flow is under-the-seat (Models 201 and 203), inlet pressure opens the valve. To close the valve, the pressure in the cover must reach the inlet pressure.

Failure of the diaphragm in this case allows the valve to remain open (fail-open).

The pressure from the cover chamber can be vented to atmosphere. When vented to atmosphere, the valve will open wide, permitting full flow with minimum of pressure drop. Figure 2 shows a control (3-way) valve for controlling the pilot loop.

The valve closes when the control closes and inlet pressure is diverted to the cover chamber above the diaphragm. The area of the diaphragm being greater than the area of the valve seat, plus the force of the spring, causes the valve to close against product flow.

## Service

The Smith Meter diaphragm valves are designed to give many years of highly efficient and satisfactory service when properly installed and operated. However, malfunctions can occur.

Therefore, the Troubleshooting Table is included in this manual to assist the serviceman in locating and correcting as many of these problems as possible.

Problems not covered here may be resolved by contacting your FMC Technologies Measurement Solutions, Inc. valve representative.

These products have been designed for petroleum applications, where corrosion/erosion is normally minimum. The design of the pressure containing housings have adequate material allowance for typical petroleum applications. Consult the factory for other applications or for the actual material allowances.

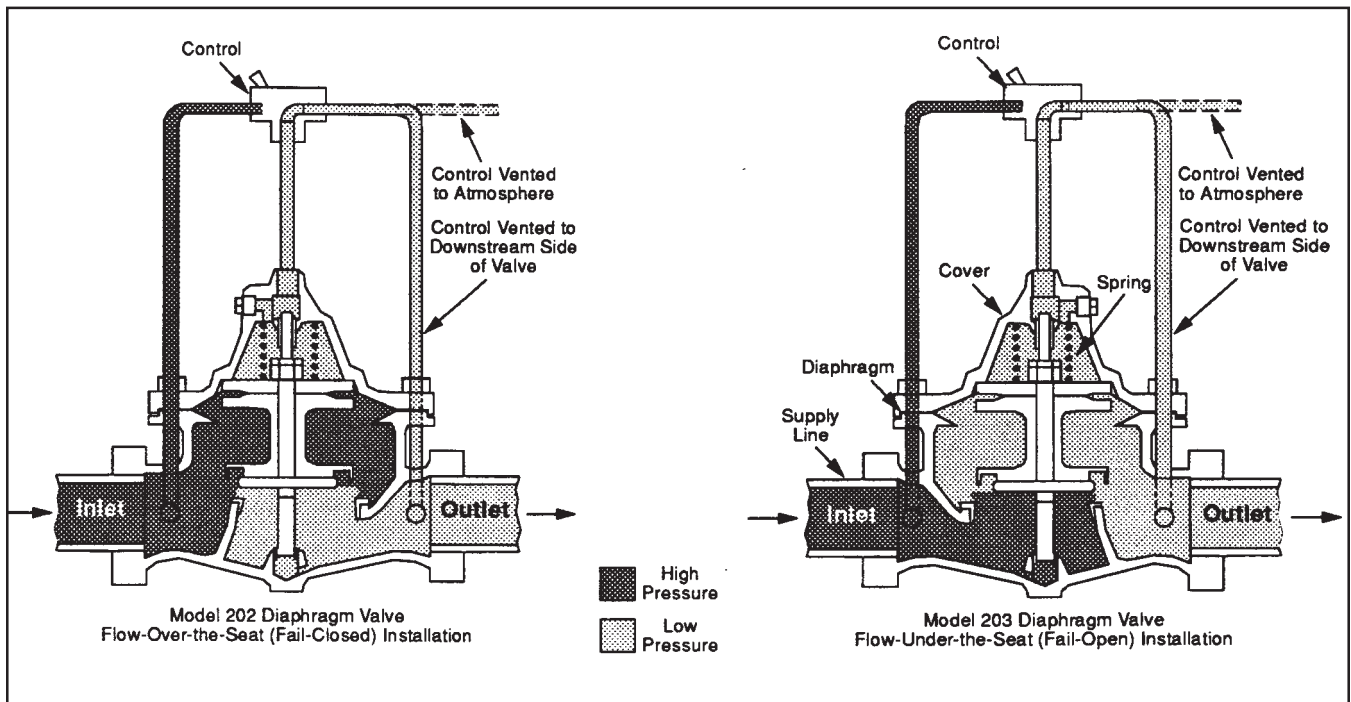

Figure 2

## Troubleshooting Table

Symptom	Probable Cause	Remedy
Valve does not open. (No pressure registers at inlet side of valve).	Insufficient differential pressure across diaphragm.	3 psi differential pressure across main valve diaphragm required to open valve.
	Upstream shutoff valve closed.	Open shutoff valve.
	Detective upstream shutoff valve.	Replace.
	Obstruction in upstream valve or line.	Remove obstruction.
Valve does not open. (Pressure registers at inlet side of valve).	Downstream shutoff valve is closed.	Open shutoff valve.
	Differential pressure across valve is too low.	Upstream pressure at inlet side of valve should read static pump head pressure. Downstream pressure should read zero pressure. Determine pump size. Replace if necessary.
	Needle valve open too far.	Adjust needle valve to reduce high pressure liquid flow through the pilot loop.
	Control pilot orifice is clogged, too small, or defective.	Inspect and replace if necessary.
	Obstruction in cover chamber of main valve.	Remove obstruction and inspect for damage.
	Ruptured diaphragm (Models 200 and 202 only).	Inspect and replace.
Main valve does not open sufficiently, creating a high pressure drop.	Needle valve is out of adjustment.	Turn adjusting stem on needle valve in (clockwise) to reduce high pressure liquid flow through the pilot loop.
	Control pilot orifice is too small.	Replace control pilot with adequate orifice size.
	Obstruction in cover chamber of main valve.	Remove obstruction and inspect for damage.
Main valve does not close.	Strainer clogged.	Clean or replace.
	Needle valve is out of adjustment.	Turn adjusting stem of needle valve out (counterclockwise) to increase high pressure liquid flow through the pilot loop.
	Broken spring in cover chamber.	Replace and inspect for damage.
	Obstruction under main valve seat.	Remove obstruction and inspect for damage.
	Control pilot defective.	Replace.
	Ruptured diaphragm (Models 201 and 203 only).	Inspect and replace.

Revisions included in MN03016 Issue/Rev. 0.1 (1/03):

Page 1: Added venting instructions.  
Page 2: Added corrosion/erosion note.

The specifications contained herein are subject to change without notice and any user of said specifications should verify from the manufacturer that the specifications are currently in effect. Otherwise, the manufacturer assumes no responsibility for the use of specifications which may have been changed and are no longer in effect.

---

**Headquarters:**

1803 Gears Road, Houston, TX 77067 USA, Phone: 281/260-2190, Fax: 281/260-2191

**Gas Measurement Products:**

**Erie, PA USA** Phone 814/898-5000  
**Thetford, England** Phone (44) 1842-82-2900  
**Kongsberg, Norway** Phone (47) 32/286-700  
**Buenos Aires, Argentina** Phone 54 (11) 4312-4736

**Integrated Measurement Systems:**

**Corpus Christi, TX USA** Phone 361/289-3400  
**Kongsberg, Norway** Phone (47) 32/286-700  
**San Juan, Puerto Rico** Phone 787/274-3760  
**United Arab Emirates, Dubai** Phone 971 +4/331-3646

**Liquid Measurement Products:**

**Erie, PA USA** Phone 814/898-5000  
**Los Angeles, CA USA** Phone 661/702-8660  
**Slough, England** Phone (44) 1753-57-1515  
**Ellerbek, Germany** Phone (49) 4101-3040  
**Barcelona, Spain** Phone (34) 93/201-0989  
**Moscow, Russia** Phone (7) 495/564-8705  
**Melbourne, Australia** Phone (61) 3/9807-2818

**Beijing, China** Phone (86) 10/6500-2251  
**Singapore** Phone (65) 6861-3011  
**Chennai, India** Phone (91) 44/450-4400

**Visit our website at [www.fmctechnologies.com](http://www.fmctechnologies.com)**