

Parts List

Technical Manual
8-017
Issued: 4/94
Supersedes: 4/91

Manual No. 251292

METER REGISTER

SERIES
7887

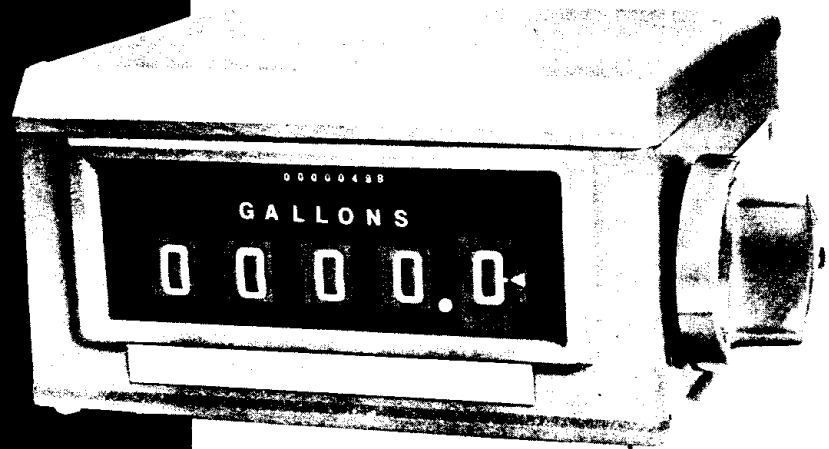

VEEDER-ROOT 
Petroleum Products

Meter Register Series 7887

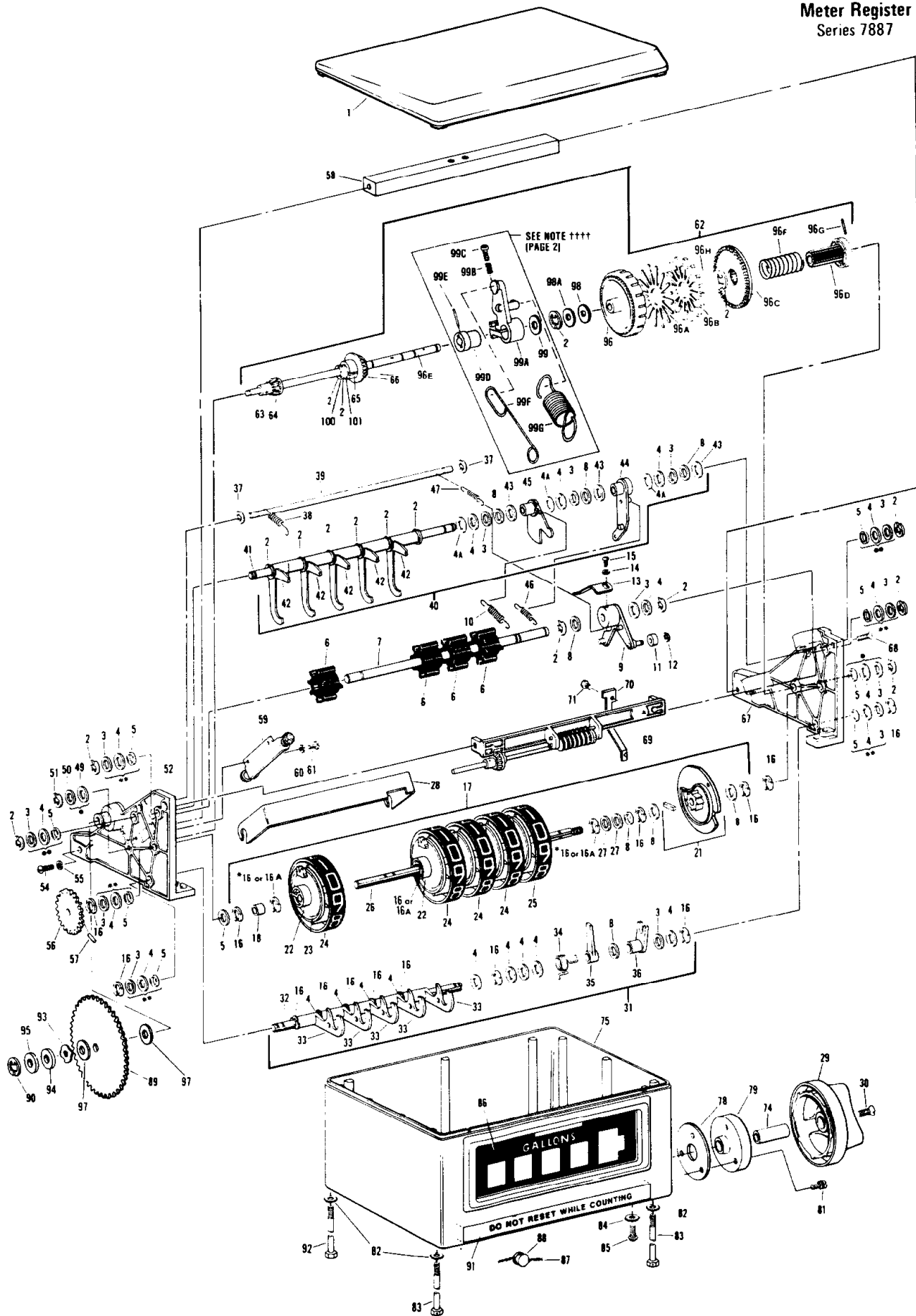

ITEM NO.	PART NO.	PART NAME	QUANTITY PER UNIT
1	80602-009	Cover	1
2	511810-001	Retaining Ring	18
3	74800-360	Washer (.005)	As Req.
4	11071-208	Washer (.010)	As Req.
4a	885005-050	Washer (.003)	As Req.
5	11071-159	Washer (.031)	As Req.
6	324601-001	Pinion-Transfer	4
7	324687-002	Shaft-Pinion	1
†	324687-003	Shaft-Pinion	1
8	11071-159	Washer (.031)	5
9	324744-001	Detent Lever Group	1
10	310300-368	Spring-Clutch	1
11	324765-001	Roller	1
12	511807-001	Retaining Ring	1
13	324651-001	Brake	1
14	510055-030	Lockwasher (No. 2)	1
15	500740-001	Screw (2-64)	1
16	511805-324	Retaining Ring	21
16a	511805-329	Retaining Ring (.025)	As Req.
17	325046-001	Wheel Shaft Group	1
18	884010-019	Sleeve-Shutter	1
19	11017-905	Washer (.014)	As Req.
20	11071-869	Washer (.006)	As Req.
21	312020-872	Kit Cam-Multiple w/key	1
22	324602-001	Eccentric	5
23	324603-001	Locking Disc	5
24	324625-002	Middle and Left Wheel	4
25		Right Hand Wheel	1
	324625-001	0-9 and 10 Grads W/B	
	324625-006	0-9 and 100 Grads W/B	
	324625-005	00-95 and 100 Grads B/W	
26	††324686-002	Shaft-Wheel	1
27	11071-965	Washer (.040)	As Req.
		Also includes 8, 16, 16A	
28	324645-001	Shutter	1
29	324757-001	Knob	1
30	503648-001	Screw	1
31	325045-001	Reset Shaft Group	1
32	324660-001	Shaft-Reset	1
33	324597-001	Finger-Reset	5
34	310340-587	Spring	1
35	324644-001	Pawl-No Back	1
36	324655-001	Arm-Reset	1
		Also includes 3, 4, 8, 16	
37	511807-001	Retaining Ring	3
38	310300-329	Spring-Anti-Topping	5
39	324693-001	Shaft-Stop	1
40	325044-001	Anti-Topping Finger Shaft Group	1
41	324682-001	Shaft-Anti-Topping	1
42	324596-001	Finger-Anti-Topping	5
43	11071-208	Washer (.010)	2
44	324743-001	Reset Lever Group	1
		Also includes 2, 3, 4, 4A, 8	
45	324747-001	Clutch Lever Group	1
46	310300-330	Spring-Reset	1
47	310300-331	Spring-Detent	1
48	74800-291	Washer (.056)	As Req.
49	11071-485	Washer (.010)	As Req.
50	11017-833	Washer (.005)	As Req.
51	511807-001	Retaining Ring	1
52	324749-002	Left-Hand Plate Group (includes 59, 60, 61)	1
53	Deleted		
54	502819-090	Screw (10-32)	2
55	510031-001	Lockwasher (No. 10)	2
56	†††403071-419	Gear-Register	1
57	510187-001	Pin, Groove	1
58	324647-001	Bar, Rear Mounting	1
59	324748-002	Bracket Group	1
60	Deleted		
61	510500-431	Screw (4-40)	2

ITEM NO.	PART NO.	PART NAME	QUANTITY PER UNIT
62	325043-001	Clutch Shaft Group	1
63	510176-001	Pin	1
64	324662-001	Bevel Gear	1
65	512900-190	Pin-Spirol	1
66	324661-001	Bevel Gear	1
		Also includes 2, 96, 96A, thru 96H, 98, 98A, 100, 101	
67	324754-001	Right-Hand Plate Group	1
68	** 501700-137	Screw (6-32)	2
	510500-419	Screw (6-32)	2
69		Totalizer Group	1
	324633-006	Right Wheel B/W	
	324633-007	All Wheels W/B	
70	324734-001	Pointer	1
71	510500-330	Screw-Self Tapping	1
72	Deleted		
73	Deleted		
74	324756-001	Shaft-Knob	1
75	324610-001	Housing	1
78	76124-005	Gasket	1
79	70718-025	Flange	1
80	Deleted		
81	511850-152	Screw	3
82	510003-006	Lockwasher	4
83	503344-032	Screw-Seal	2
84	510020-001	Lockwasher (.250)	3
85	503600-104	Screw (1/4-28 x 3/4)	3
86		Crystal	1
	324695-001	Gallons	
	324695-015	Gallons & Decimal	
	324695-002	Liters	
	324695-012	Liters & Decimal	
	324695-003	Pounds	
	324695-004	Imperial Gallons	
	324695-011	Imp. Gals. & Decimal	
	324695-005	Dekaliters	
	324695-006	Meter Units	
	324695-010	Barrels	
	324695-014	M ³	
87	11853-285	Seal Wire	1
88	44602-005	Lead Seal	1
89	403071-420	Gear-Idler	1
90	511800-106	Ring-Retaining	1
91	328065-001	Label-Warning	1
92	503300-111	Screw	2
93	885005-937	Washer-Wave Spring	1
94	885005-789	Washer	As Req.
95	885005-791	Washer	As Req.
96	324600-001	Disc-Clutch	1
96A	320279-001	Spring	1
96B	320255-001	Disc	1
96C	324598-001	Coupling	1
96D	324599-001	Driver	1
96E	324663-001	Shaft-Clutch	1
96F	310325-270	Spring	1
96G	512921-001	Pin-Spirol	1
96H	11071-905	Washer (.014)	1
97	†††† 885005-791	Washer	2
98	†††† 11071-208	Washer	As Req.
98A	†††† 74800-360	Washer	As Req.
99	†††† 885005-785	Washer	1
99A	†††† 328418-001	Pawl	1
99B	†††† 14427-046	Spring	1
99C	†††† 501536-001	Screw (#5-40 x 5/8)	1
99D	†††† 328428-001	Hub	1
99E	†††† 512211-001	Pin-Roll (.083 x .750)	1
99F	†††† 328419-001	Clip	1
99G	†††† 310300-378	Spring	1
100	11071-DG-208	Washer (.010)	2
	74800-188-360	Washer (.005)	4
	74800-188-360	Washer (.005)	2
101	11071-DG-208	Washer (.010)	1

- Note: Items indented under a Group are part of that Group and will be included with the Group when ordered. Individual items may be ordered as individual parts.
- * After installing retaining ring (Item 16), pull wheel group against retaining ring. Manually rotate the wheel. If it does not spin freely, replace Item 16 with Item 16a.
 - ** Use Items 3, 4 and 5 as required to obtain end play of between 0.005 and 0.012 inch.
 - Use Items 49 and 50 on left side and Items 3, 4 and 5 on right side as required for proper totalizer bevel gear engagement while maintaining 0.005-0.012 shaft end play.
 - Use Items 3, 4 and 5 as required to adjust the clutch for proper operation with the input clutch while maintaining a maximum end play of 0.007 inch.
 - † For units with Serial Number 372025 and above.
 - †† For units with Serial Number 372025 and above. May be used with Serial Number 372024 and below, but gear item no. 56, must have Hub facing inward as shown.
 - ††† For units with Serial Number 372025 and above, gear is assembled with Hub toward inside (as shown).
For units with Serial Number 372024 and below, gear is assembled with Hub toward outside.
 - †††† These parts not included in Domestic registers. Parts shown are used only in EEC (European Economic Community) registers.
 - ** For units with Serial Number below 538693.
 - * For units with Serial Number 538693 and above.

**GEAR PLATE ASSEMBLY
(TYPE 5)**

**GEAR LIST
(Item 103)**

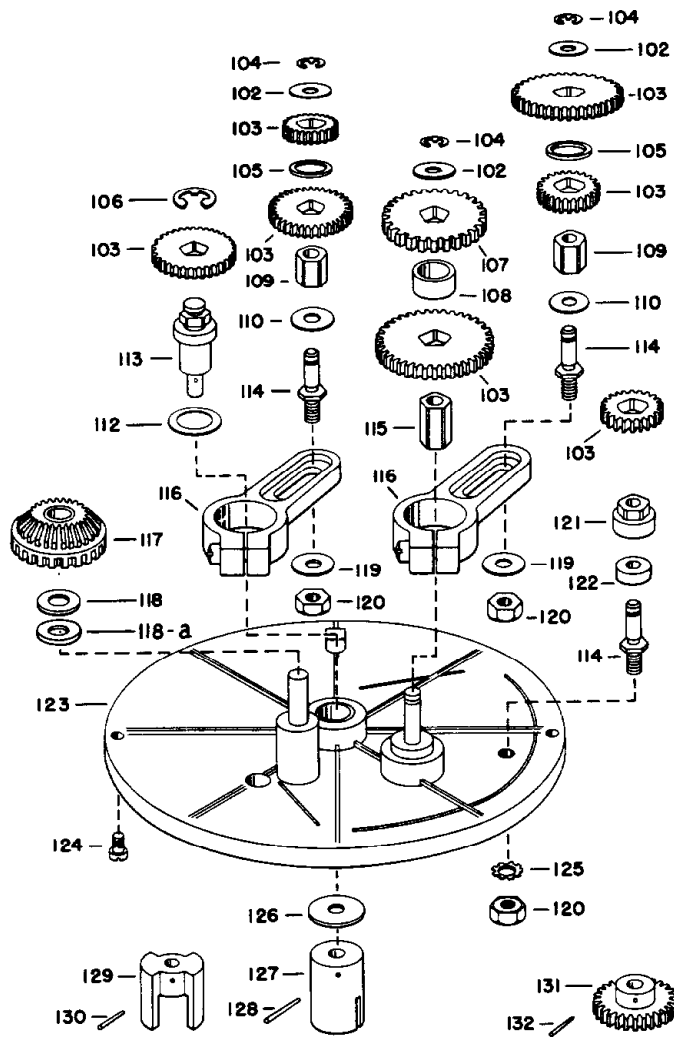

PART NO.	NO. OF TEETH	PART NAME
77348-005	19	*Gear
32996-019	19	**Gear
311427-120	20	*Gear
311427-110	20	**Gear
311427-130	26	**Gear
32996-028	28	Gear
32996-029	29	Gear
32996-030	30	Gear
32996-031	31	Gear
32996-032	32	Gear
32996-033	33	Gear
32996-034	34	Gear
32996-035	35	Gear
32996-036	36	Gear
32996-037	37	Gear
32996-038	38	Gear
32996-039	39	Gear
32996-040	40	Gear
32996-041	41	Gear
32996-042	42	Gear
32996-043	43	Gear
32996-044	44	Gear
32996-045	45	Gear
32996-046	46	Gear
32996-047	47	Gear
32996-048	48	Gear
32996-049	49	Gear
32996-050	50	Gear
32996-051	51	Gear
32996-052	52	Gear
32996-053	53	Gear
32996-054	54	Gear
32996-055	55	Gear
32996-056	56	Gear
32996-057	57	Gear
32996-058	58	Gear
32996-059	59	Gear
32996-060	60	Gear
32996-061	61	Gear
32996-062	62	Gear
32996-063	63	Gear
32996-064	64	Gear
32996-065	65	Gear
32996-066	66	Gear
32996-067	67	Gear
32996-068	68	Gear
32996-069	69	Gear
32996-070	70	Gear
32996-071	72	Gear
32996-075	75	Gear
32996-076	76	Gear
32996-080	80	Gear
32996-084	84	Gear

*Round hub/round hole
**Pentagon hub/round hole

ITEM NO.	PART NO.	PART NAME	QUANTITY PER UNIT
102	11071-135	Washer (0.010)	3
103	See Gear List.	Change Gears	
104	511807-001	Retaining Ring	3
105	11071-199	Washer (0.047)	2
106	511810-001	Retaining Ring	1
107	70827-005	Gear (25T)	1
108	14571-792	Spacer	1
109	33534-015	Bushing	2
110	11071-171	Washer (0.020)	2
112	11071-929	Washer (0.010)	1
113	70659-010	Drive Shaft	1
114	326586-001	Stud	3
115	33534-050	Bushing	1
116	33534-005	Swing Arm Assembly	2
117	70828-005	Gear Assembly	1
118	11071-479	Washer (0.030)	1

ITEM NO.	PART NO.	PART NAME	QUANTITY PER UNIT
118a	11071-333	Washer (0.020)	As Req.
	11071-325	Washer (0.010)	As Req.
	11071-803	Washer (0.005)	As Req.
119	11071-187	Washer (0.031)	2
120	511038-001	Hex Nut (10-32)	3
121	74843-005	Bushing	1
122	65009-005	Spacer	1
123	70856-010	Gear Plate	1
124	502230-001	Flat Fil. Hd. Screw (8-32 x 1/4")	2
125	510002-001	Lockwasher	1
126	11071-933	Washer (.010)	1
127	65004-005	Coupling	1
128	510105-177	Groove Pin (1/16" x 5/8")	1
129	33775-005	Coupling	
130	510107-002	Groove Pin (1/16" x 7/16")	
131	32948-015	24T Gear	
	65116-005	36T Gear	
132	510105-179	Groove Pin for 24T Gear	
	510108-001	Groove Pin for 36T Gear	

GEAR PLATE ASSEMBLY (TYPE 7)

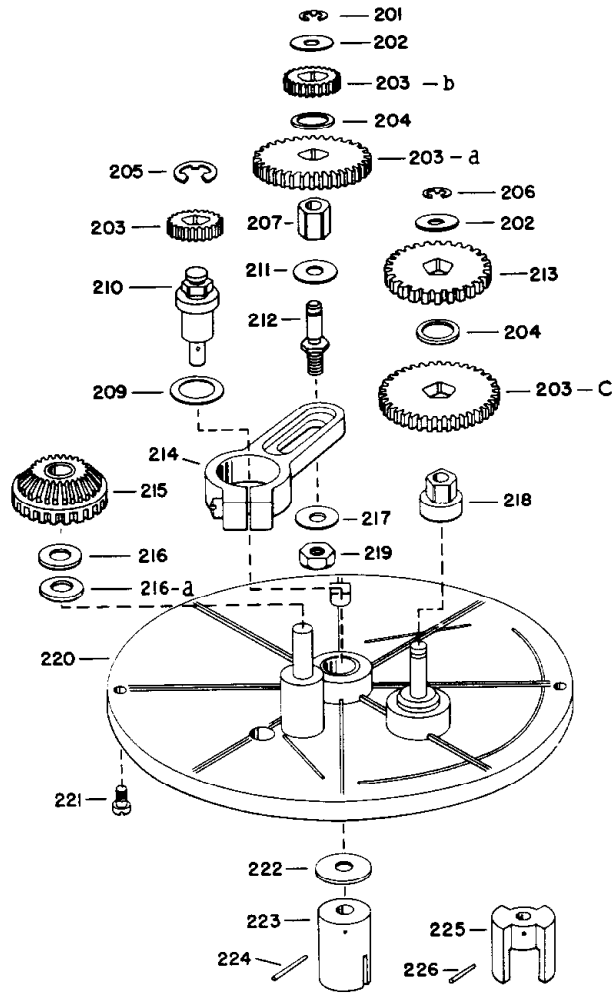

ITEM NO.	PART NO.	PART NAME	QUANTITY PER UNIT
201	511807-001	Retaining Ring	1
202	11071-135	Washer (.010)	2
203	32996-033	33T Gear (For 4:1 ratio)	1
	32996-028	28T Gear (For 8:1 ratio)	1
203a	32996-066	66T Gear (For 4:1 ratio)	1
	32996-084	84T Gear (For 8:1 ratio)	1
203b	32996-033	33T Gear (For 4:1 ratio)	1
	32996-030	30T Gear (For 8:1 ratio)	1
203c	32996-066	66T Gear (For 4:1 ratio)	1
	32996-080	80T Gear (For 8:1 ratio)	1
204	11071-199	Washer (.047)	2
205	511810-001	Retaining Ring	1
206	511807-001	Retaining Ring	1
207	33534-015	Bushing	1
209	11071-929	Washer (.010)	1
210	70659-010	Drive Shaft	1
211	11071-171	Washer (.020)	1

ITEM NO.	PART NO.	PART NAME	QUANTITY PER UNIT
212	326586-001	Stud	1
213	70827-005	Gear (25T)	1
214	33534-005	Swing Arm Assembly	1
215	70828-005	Gear Assembly	1
216	11071-479	Washer (.030)	1
216a	11071-333	Washer (.020)	As Req.
	11071-325	Washer (.010)	As Req.
	11071-803	Washer (.005)	As Req.
217	11071-187	Washer (.031)	1
218	76551-005	Bushing	1
219	511038-001	Hex Nut (10-32)	1
220	70856-010	Gear Plate	1
221	502230-001	Flat Fil. Hd. Screw (8-32 x 1/4")	2
222	11071-933	Washer (.010)	1
223	65004-005	Coupling	1
224	510105-177	Groove Pin (1/16" x 5/8")	1
225	33775-005	Coupling	1
226	510107-002	Groove Pin	1

**GEAR PLATE ASSEMBLY
(TYPE 1)**

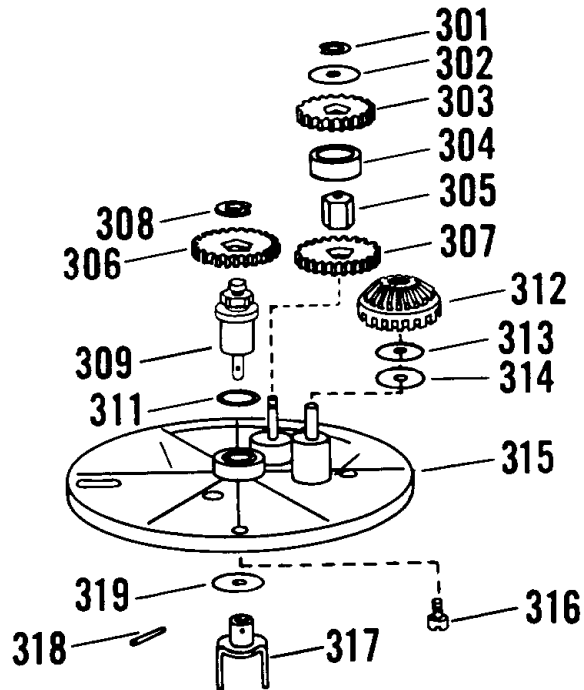

ITEM NO.	PART NO.	PART NAME	QUANTITY PER UNIT
301	511807-001	Retaining Ring	1
302	11071-135	Washer (.010)	1
303	70827-005	Gear (25T)	1
304	14571-792	Spacer	1
305	33534-050	Bushing	1
306	73296-195	39T Gear (For 1:1 ratio)	1
	73296-130	26T Gear (For 2:1 ratio)	1
307	73296-195	39T Gear (For 1:1 ratio)	1
	73296-260	52T Gear (For 2:1 ratio)	1
308	511810-001	Retaining Gear	1
309	70659-010	Drive Shaft	1
311	11071-929	Washer (.010)	1

ITEM NO.	PART NO	PART NAME	QUANTITY PER UNIT
312	70828-005	Gear Assembly	1
313	11071-479	Washer (.030)	1
314	11071-333	Washer (.020)	As Req.
	11071-325	Washer (.010)	As Req.
	11071-803	Washer (.005)	As Req.
315	70856-010	Gear Plate	1
316	502230-001	Flat Fil. Hd. Screw (8-32 x 1/4")	2
317	68845-005	Coupling	1
318	510107-002	Groove Pin (1/16" x 7/16")	1
319	11071-933	Washer (.010)	1

VEEDER-ROOT 
Petroleum Products

6th Avenue at Burns Crossing, P.O. Box 1673, Altoona, PA 16603-1673 TEL: (814) 695-4476, FAX: (814) 695-7605

BRAZIL: Sao Paulo • FRANCE: Rungis Cedex • GERMANY: Neuhausen/Filder