

Depot equipment with Depot TAG
NoMix

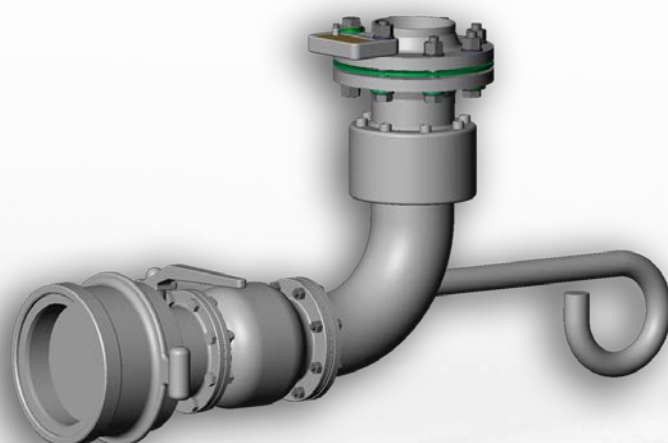

Further documentation about this product:

Designation	Order No.
None	

Documentation on the Internet:

www.fmctechnologies.com/seningttp

History

Revision	Date	Originator	Status	Description
Rev. 1.11	June 2003	HO	Approval	First edition
Rev. 1.20	April 2006	JP	Approval	Format changes / new drawings
Rev. 1.21	August 2006	HO / JP	Approval	New insulation kit DLISO48-D in drawing 51.251458
Rev. 1.22	November 2006	JP	Approval	ESD nominal resistance value changed from 5 to 10Ω
Rev. 1.23	April 2007	JP	Approval	- Chap. 3 DN80 PN16 Upgrade- change in drawing 52.251458 - New drawing 61.251939
Rev. 1.24	June 2008	HO / RA / jp	Approval	- New drawings - Chapter 4.4 new - Expanded TAG information

Table of Contents (English)

Table of Contents (English)	3
1 General	5
1.1 Orientation aids for the manual	5
1.2 Safety instructions	6
1.2.1 Proper intended use	6
2 Device description	7
2.1 Basic Functions	7
2.2 Installation	7
2.2.1 Equipotential Bonding	7
2.2.2 Safety Notice	7
3 Assembly	8
3.1 Loading Arm and Vapour Recovery Hose	8
3.2 TAGs	9
3.3 TAG Identifiers / Assignment (Depot TAGs)	10
3.4 TAG Mounting and Isolation Kit	11
4 Measurements After Installation	12
4.1 General	12
4.2 Measurement Points	12
4.3 Measurement	13
4.4 Problems during measurement	13
4.5 Sample Measurement Log	15
5 Repairs / Identification	16
5.1 Repairs	16
5.2 Identification	16
5.3 Explosion Protection Notes	16
6 Maintenance	17
6.1 Testing	17
7 Technical Data	18
7.1 NoMix Depot TAG	18

8	Address and contact details	20
	Index	22
	Drawings	23
	Copy Master "Measurement Log".....	23
	E51.251458 - Depot-TAG Data Acquisition Flange TTMA 4" - sheet 1	24
	E51.251458 - Depot-TAG Data Acquisition Flange DN80 / PN16 - sheet 2	25
	E54.251458 - Depot-TAG Data Acquisition Flange DN80 / PN16 - sheet 3	26
	E54.251458 - Depot-TAG Data Acquisition Flange DN100 / PN40 - sheet 4	27
	E61.351580 - Principle Diagram - NoMix Loading	28
	E51.351146 - Depot TAG installation (electrical wiring).....	29
	E61.251364 - Depot TAG Segment DN100 / PN16	30
	E61.251365 - Depot TAG Segment TTMA 4"	31
	E61.252003 - Depot TAG Segment D100 / PN40.....	32
	E61.251939 - Depot TAG Segment DN80 / PN16	33
	E51.351624 - TAG Connection to loading arm (overview).....	34
	E51.351625 - TAG Connection to vapour arm (overview)	35
	E51.351626 - TAG Connection to product / vapour recovery hose arm (detail) - sheet 1	36
	E52.351626 - Depot TAG Installation Product- / Vapour Measuring of bleeder resistance - sheet 2.....	37
	Product Grade / Coding-TAG's - DN100 / PN16	38
	Product Grade / Coding-TAG's - DN100 / PN16	39
	Product Grade / Coding-TAG's - TTMA4"	40
	Product Grade / Coding-TAG's - DN80 / PN16	41
	Product Grade / Coding-TAG's - DN100 / PN40	42
	Approvals	43
	EC-Declaration of Conformity.....	43

1 General

1.1 Orientation aids for the manual

We have provided some orientation aids so that you can easily find the necessary information in this manual.

The information in this manual ranges from imperative safety procedures and standardized guidelines through to concrete handling procedures and advice. To differentiate these more easily, the information is marked with corresponding pictograms in front of the relevant text.

These are intended not just to draw particular attention to these passages, but also to make it easier to find the information you want. Therefore the pictograms are symbolic of the underlying textual content.

The following pictograms are used in this manual:



Danger sign

Danger of explosions caused by easily ignited gases and liquids here.



Risk of operating fault

Actions that may damage the equipment.



Legal notice

Actions that may have legal consequences.



Working step

Concrete action statements, e.g.: *“Press the <Enter> key”*.



Input necessary

e.g. via numeric or function keys.



Positive response message

e.g. *“The main menu now appears”*



Negative response message

e.g. *“If a fault message appears now...”*



Background information

Short-Tip, e.g. *“See more detailed information in chapter XX”*.



Option

Special case.



Function

Functional description.



NOTE:

indicates a special situation.



ATTENTION:

particular attention is to be paid.







1.2 Safety instructions



Caution:

This information must be carefully read and observed before operating the unit.

1.2.1 Proper intended use

-  The TAG is used exclusively for quality control in collaboration with measuring systems on tank trucks. The corresponding applicable safety regulations (e.g. Ex protection) must be complied with.
-  Any form of use which exceeds the scope described above is deemed to be improper use; the F. A. Sening GmbH is not liable for damages resulting from such improper use.
-  Proper use also includes compliance with the conditions set out by the F. A. Sening GmbH with regard to operation, installation and maintenance.
-  The TAG must only be operated, serviced and repaired by personnel who are familiar with the equipment and who have been trained regarding the dangers involved.
-  If you discover any signs of damage or breakage on any parts of the system or if the system's safe operation cannot be guaranteed for any other reason, do not start the system or, if already in operation, shut down the system immediately. Notify your maintenance department.
-  The F. A. Sening GmbH cannot be held liable for any damages arising as a result of unauthorized changes to the system.

2 Device description

2.1 Basic Functions

- The requirement for the proper function of the system are trucks having the NoMix cross over prevention system installed.
- On the depot side, as part of the system, electronic identification sources are installed at the loading arms of the individual products and at the vapour recovery connection.
- These devices contain electronic components and store various data - such as the product grade. These units are called TAGs.
- When the loading arm and vapour recovery hoses are connected, the corresponding TAGs are supplied with a small, intrinsically safe voltage.
- The TAG immediately begins to send its internally stored information to the system on the tank truck.
- As soon as a proper connection has been established and verified by the on-board system, the system permits the procedure and loading can be started.

2.2 Installation

2.2.1 Equipotential Bonding

 For the NoMix system to work properly, all connections between the truck and the loading bay must have the same electric potential with a resistance of max. 10 Ω. The connections are all loading arms, the vapour recovery connection and the ground wire (Scully).

 Before beginning installation, verify this by taking the appropriate measurements (description for testing and form for the protocol see chapter 4.2 "Measurement Points" / page 12).

2.2.2 Safety Notice

 For all tasks described in this manual, always apply the currently valid versions of the appropriate DIN standards and VDE regulations (e.g. DIN 57100/VDE 0100) or equivalent local standards.

 The installation of all NoMix Depot components must always be complete for each loading bay, i.e. for each loading arm and the vapour recovery adaptor. Whenever a product or vapour recovery flange insulation is mounted, the corresponding connections of the TAG must be connected immediately to ensure the function of preventing electrostatic load.

3 Assembly

- ☐ Different manufacturers offer their products for loading arm equipment in different variants. The TAG fastening is made to the respective arms of the Flange. For fastening the TAGs is between two mounting versions for DIN flange DN100/PN16 or TMA flange 4 "differentiated.
- ☐ To simplify the order is for each load trace a copy of Drawing No. **52.251458** sheets 1 to 4 fill. All relevant data that are necessary for correct and complete order must be entered in this sheet.
- ☐ The different manufacturers for loading arm equipment offer their products in various models. The fixing of the TAGs occurs on flange transitions of the relevant arms. To fasten the TAGs, a distinction is made between two fastening versions, for DIN flange DN100/PN16 or for a 4" TTMA flange.
- ☐ To simplify ordering, one copy of Drawing No. **52.251458** Pages 1 thru 4 / from Page 24 must be filled out for every loading lane. All relevant data required for a correct and complete order must be recorded on this sheet.

3.1 Loading Arm and Vapour Recovery Hose

Required drawings to complete this work:

E51.351624	E51.351625	E51.351626
------------	------------	------------

- ☞ To start the assembly of the TAGs each loading arm needs to be drained off. After disassemble the existing flange connection, all screws will be exchanged against insolated screws with insulating washers of the same size (drawing **E51.351626** / page 36). The former gasket will be changed against insolated gasket. In case of vapour recovery hose installation instead of an vapour recovery arm, in most cases the connector for the vapour recovery hose needs to be changed against a flange type of connector (see detail) to accept the TAG housing.

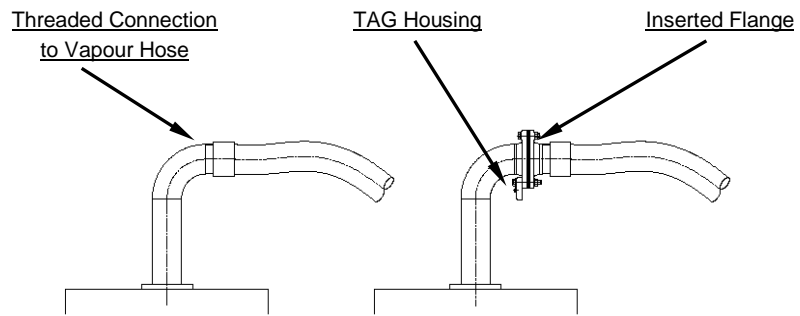

Fig. 1: Loading Arm and Vapour Recovery Hose

- ☞ The TAG has to be mounted in a protected location at the product / vapour recovery arm (e.g. on the vertical or horizontal pipe). The overhanging housing of the TAG must not interfere a secure handling.
- ☞ The electrical connection of the TAG is done through the housing itself, both with the flange facing and the joint plate. All swivel joints must be electrically bypassed with a contact wire (VA steel wire $\varnothing 4$), as they otherwise might not conduct electricity in certain positions.

3.2 TAGs

- ☞ An individual TAG with the corresponding product information is installed for each product; a so-called “common vapour TAG” is installed on the vapour recovery line. It is essential that a “Depot TAG” of the correct grade is installed on the corresponding loading arm.
- ☞ To identify the a Depot-TAG and a Service Station TAG respectively, a “DL” for “Depot Liquid” and a “SL” for “Station Liquid” in the part of the part number, for example:

Depot TAG / TTMA 4" Flange:	“Super Unleaded 98” : Part-No. DL98U-T
Depot TAG / DIN DN100/PN16 Flange:	“Super Unleaded 98” : Part-No. DL98U-D
Depot-TAG / DIN DN 80 PN 16 Flange:	„Super Unleaded 98“: Part-No. DL98U-D-DN80
Service station TAG:	“Super Unleaded 98” : Part-No. ASS-NS-SL98U

The part number can be found on the product label.

3.3 TAG Identifiers / Assignment (Depot TAGs)

☐ The housing of the TAGs is a shape casting, one side formed according to the screw-hole circle of either TTMA or DIN flanges. The electronic is potted inside of this housing. The TAGs are coming fully equipped and tested. The product label shows part number / product grade, serial number and manufacturing code. The DN80 PN16 Flange construction supplemented with the product label -D-DN80.

Part number		Grade	Description
DL98L	-T -D	98 octane leaded	4 Star / LRP
DL98U	-T -D	98 octane unleaded	Super Unleaded 98
DL95U	-T -D	95 octane unleaded	Unleaded 95 (Ultra Low Sulfur)
DLDI	-T -D	Diesel "variant A"	Diesel (Ultra Low Sulfur)
DLDB	-T -D	Diesel "variant B"	Gas Oil
DLDC	-T -D	Diesel "variant C"	Kerosine
DVCMA	-T -D	---	Common vapour

Table 1: TAG Identifiers

✍ The project drawings **E61.251365** (TTMA Flange) and **E61.251364** (DIN DN100 PN16Flange) are showing the complete order information and **E61.251939** (DN80 PN16 Flange).

3.4 TAG Mounting and Isolation Kit

 To simplify the installation of the TAG brackets at the flange of the loading / vapour arms mounting and isolation kits have been put together. The kit needed results of the measurement “B” (drawing **E52.251458** sheet 1 until 2).

Mounting Kit for TTMA 4“	Measurement B [mm]	Mounting Kit for DN 100 PN 16	Measurement B [mm]
DLISO25-T	22 – 27	DLISO30-D	28 – 33
DLISO30-T	28 – 32	DLISO36-D	34 – 39
DLISO35-T	33 – 38	DLISO42-D	40 – 45
DLISO48-D	46 - 52		
DLISO64-D	61 - 67		

Table 2: TAG Mounting DN 100 PN 16

Mounting Kit for DN 80 PN 16	Measurement B [mm]
DLISO30-D-DN80	28 - 33
DLISO36-D-DN80	34 - 39
DLISO42-D-DN80	40 - 45
DLISO48-D-DN80	46 - 52
DLISO61-D-DN80	59 - 63
DLISO120-D-DN80	118 - 122

Table 3: TAG Mounting DN 80 PN 16

 Each Kit consists of all necessary screws, nuts, washers and gaskets.



Note:

All screws except for the longer screw over which the connection to the TAG Electronics is prepared should, if possible on the plus side (flange that faces the filler coupling) can be mounted with the screw head and the insulating. On the minus side (flange, facing the tank farm) then the connection is made without having an insulating washer and the nut. (See drawing **52.351626** / page 36) Only in exceptional cases, space problems, the screws are installed the other way around and isolated (see drawing **52.351626** / page 37).



Recommendation:

To protect against the weather is recommended that the complete installation TAG, TAG including housing, insulating screw, and insulating the Complete flange after installation and measurement to be painted with a suitable protective coating. The TAG label on the bottom is masked off to ensure that the data contained therein are retained.

4 Measurements After Installation

4.1 General

Required drawings to complete this work:

E51.351624	E51.351625	E51.351626
------------	------------	------------



Once the depot installation is complete, various measurements must be performed to ensure that the NoMix System is working well.

- A suitable explosion-proof measurement device must be used for these measurements;
- the measurement voltage of the device must be equal or less 10 VDC, (e.g. digital multimeter from EX-ELEC, type DIGEX-A).



Isolation test devices with measurement voltages greater than 10 VDC may not be used, as this may destroy electronic components.



Measurement points are illustrated in the drawings by a rectangular frame.

Example:

3

4.2 Measurement Points

Measurement Point	Description
1	Joint plate of the product / vapour TAG
2	Housing of the product / vapour TAG
3	Product / vapour recovery coupling

Table 4: Measurement Point

4.3 Measurement

Drawing numbers E51.351624 / page see chapter 4.5 "Sample Measurement Log" / page 15, E51.351625 / page see chapter 0 "E51.351625 - TAG Connection to vapour arm (overview)

" / page 35 and E51.351626 / page see chapter 0 "E51.351626 - TAG Connection to product / vapour recovery hose arm (detail) - sheet 1

☞ " / page 36, which illustrate a sample diagram of a depot loading arm and vapour recovery connection, contain measurement points 1 through 3. The measurements must be performed between the measurement points listed in the following table, and recorded in the measurement log - which can be found in the appendix - as shown in the sample measurement log contained in Chapter see chapter 4.5 "Sample Measurement Log" / page 15.

Measurement of Resistance	
Measurement between meas. points	The following values must be attained:
1 → 2	$R \geq 10 \text{ K}\Omega / \leq 500 \text{ K}\Omega$; value approx. 220 k Ω
1 → 3	$R < 10 \Omega$ Measurement between the flange isolation of each loading / vapour recovery arm and the product / vapour recovery coupling.
2 → 2	$R < 10 \Omega$ Measurement between all existing loading / vapour recovery arms.

Table 5: Measurement of Resistance

4.4 Problems during measurement

Because of electro-chemical processes which are caused due to humidity or as a result of humidity during which transient voltage / currents develop, the measuring values for the measuring devices described in chapter 4 "Measurements After Installation" / page 12 may vary significantly from the resistance values listed in the above table under certain circumstances. (Extremely high or low measured value reading or no display at all). In this case, proceed as follows. (See Drawing 52.351626 Page 2 chapter 0 "E52.351626 - Depot TAG Installation Product- / Vapour Measuring of bleeder resistance - sheet 2

☞ " / page 37):

- Remove all trace of moisture from the TAG installation (cloths, compressed air)
- Measure and record resistance R1 between TAG housing and flange half-section that faces the tank farm (minus side).

- Measure and record resistance R2 between the connecting plate / M5 connecting screw and the flange half-section that faces the loading coupling (plus side).
- Remove connection plate by unfastening the M5 connecting screw from the positive connection on the TAG housing. It may be necessary to unfasten the flange screw and turn the connection plate to one side.
- Measure and record resistance R3 between the TAG positive connection and the flange half-section that faces the tank farm (minus side).
- The resistance value for the resistance used to dissipate an electrical charge, measurements 1 → 2, is obtained by adding together $R1+R2+R3$. Enter this value in the test record (Requirement: $R \geq 10 \text{ Kohm} / \leq 500 \text{ Kohm}$)
- Reattach connection plate to the TAG plus connection with M5 screw and retighten the flange screw, if required.

4.5 Sample Measurement Log

Measurement Log

Depot <i>Smith Storage plt</i> <i>51, Crude Oil Road</i> <i>Brownshire</i> <i>AB12 3DE</i>	Installation Company <i>John Brown</i> <i>34, Shortcut Place</i> <i>Smithshire</i> <i>FG45 6HI</i>
---	---

Measurement Point	Description
1	Joint plate of the product / vapour TAG
2	Housing of the product / vapour TAG
3	Product / vapour recovery coupling
Measurement of Resistance	
Measurement between meas. points	The following values must be attained:
1 → 2	R ≥ 10 KΩ / ≤ 500 KΩ ; value approx. 220 kΩ
1 → 3	R < 10 Ω Measurement between the flange isolation of each loading / va-pour recovery arm and the product / vapour recovery coupling.
2 → 2'	R < 10 Ω Measurement between all existing loading / vapour recovery arms.

Electrostatic Discharge Resistor / Potential Difference							
Nominal Value	Product /Vapour	<i>(DL98L)</i>	<i>(DL98U)</i>	<i>(DL95U)</i>	<i>(DLDI)</i>	<i>(DLDB)</i>	<i>Vapour</i>
10KΩ ≤ R ≤ 500KΩ ca. 220 KΩ	1 → 2	<i>218 KΩ</i>	<i>223 KΩ</i>	<i>217 KΩ</i>	<i>222 KΩ</i>	<i>220 KΩ</i>	<i>219 KΩ</i>
R < 10 Ω	1 → 3	<i>0.3 Ω</i>	<i>0.7 Ω</i>	<i>1.4 Ω</i>	<i>1.1 Ω</i>	<i>0.6 Ω</i>	<i>1.0 Ω</i>

Potential Differenz						
Nominal Value	Product X ↓ Product Y Vapour/Earth	<i>DL98L</i> ↓ <i>DL98U</i>	<i>DL98U</i> ↓ <i>DL95U</i>	<i>DL95U</i> ↓ <i>DLDI</i>	<i>DLDI</i> ↓ <i>Vapour</i>	<i>-----</i> ↓ <i>-----</i>
R < 10 Ω	<i>2_X → 2_{Y/G}</i>	<i>0.5 Ω</i>	<i>2 Ω</i>	<i>2.1 Ω</i>	<i>2.2 Ω</i>	<i>Ω</i>

Installation Date and Signature:

1.4.2006 / John Brown

5 Repairs / Identification

5.1 Repairs



For repairs, as well, a NoMix depot installation must be done complete for each product arm and vapour recovery hose. If an individual product or vapour recovery flange isolation is replaced, the appropriate TAG must also be connected to ensure that any electrostatic load can be discharged.



After the repair of any NoMix components, the complete measurement must be carried out again in accordance with the measurement log.

5.2 Identification

The necessary information according to the identification, the approval and other details are printed on the product label (refer to drawing **E41.351695**).

5.3 Explosion Protection Notes

- All components labelled with the  sign are explosion-proof electrical devices. They have been safety checked and certified.
- In case of a fault, the complete module must be replaced. A specialist must install the devices.
- The electrical installation must be carried out in accordance with IECEx / DIN 60079-14 (VDE165) or equivalent local regulations. All components are explosion-proof electrical devices that have been safety checked and certified.
- The housing of the TAG is explosion-proof according to type of protection „d“ flameproof enclosure.
- In the case of a damage the TAG housing is to be exchanged the complete TAG. In the flameproof enclosure is the sensor with electronics.
- In the TAG housing are no construction units maintenance or an adjustment require.



No intervention, either mechanical or electrical, is permitted
RISK OF EXPLOSION

6 Maintenance



The components of the Depopt TAGs are in principle maintenance-free. If, however, as a result of environmental influences such as Humidity, electrochemical reactions, contamination, or rust particles are detected, they must be removed with a brass or plastic brush.

6.1 Testing

§ The basis for the testing ('Ex' areas) is the German Ordinance on Industrial Safety and Health (Betriebssicherheitsverordnung) which stipulates that testing must be carried out before initial start-up/commissioning and that this must be followed by a regular series of inspections at 3 year intervals, conducted by an approved monitoring body ('ZÜS'). These regular tests also must be carried out in accordance with internal company agreements. We, the manufacturer, do not stipulate any more extensive tests. Furthermore, the operator is free, subject to internal company agreements, to specify further testing in the event of possible damage caused, for example, by welding work, thunderstorms etc.

This should be incorporated in the standard workplace work plan.

7 Technical Data

7.1 NoMix Depot TAG

EC type examination certificate	TÜV 02 ATEX 1981 TUN 14.0039
Permissible ambient temperature	- 20 °C ... + 60 °C
Labeling ATEX  2 II G IECEx	Ex ia IIB T4 Ga
Type TAG 1.-... TAG-Electric circuit (Terminals L,+,-)	in the protection type intrinsic safety EEx ia IIB $U_i = 15 \text{ V}$ $I_i = 300 \text{ mA}$ $P_i = 1,1 \text{ W}$ $C_i = 600 \text{ nF}$ The effective internal inductance is negligible small
Type TAG 1.-... TAG-Electric circuit (Terminals G, L,+,-)	in the protection type intrinsic safety EEx ia IIB $U_i = 15 \text{ V}$ $I_i = 300 \text{ mA}$ $P_i = 1,1 \text{ W}$ $C_i = 600 \text{ nF}$ The effective internal inductance is negligible small
Type TAG 1 ESD.-... TAG-Electric circuit (Terminals G, L,+,-)	in the protection type intrinsic safety EEx ia IIB $U_i = 15 \text{ V}$ $I_i = 300 \text{ mA}$ $P_i = 1,1 \text{ W}$ $C_i = 100 \text{ nF}$ The effective internal inductance is negligible small
Type TAG 1Z.-... bzw. Type TAG 1.-... with protective circuit Type 3Z.-... TAG-Electric circuit(s) (Terminals +,-)	in the protection type intrinsic safety EEx ia IIB $U_i = 15 \text{ V}$ $I_i = 400 \text{ mA}$ $P_i = 1,475 \text{ W}$ $C_i = 600 \text{ nF}$ The effective internal inductance is negligible small The maximum values result from that Interconnection, the TAG circle of the NOMIX control and an intrinsically safe circuit (e.g. grounding test equipment) with the following maximum values: $U_i = 15 \text{ V}$ $I_i = 100 \text{ mA}$ $P_i = 0,375 \text{ W}$
Type TAG 1.-P... TAG-Electric circuit (Terminals 1,2,3,4)	in the protection type intrinsic safety EEx ia IIB $U_i = 15 \text{ V}$ $I_i = 300 \text{ mA}$ $P_i = 1,1 \text{ W}$ $C_i = 600 \text{ nF}$ The effective internal inductance is negligible small



Conformity with the EC Directive 2004/108/EC

8 Address and contact details

Our service department will be happy to assist and can be contacted as follows:



Measurement Solutions

F. A. Sening GmbH

Regentstrasse 1
D-25474 Ellerbek

Tel.: +49 (0)4101 304 - 0 (Switchboard)

Fax: +49 (0)4101 304 - 152 (Service)

Fax: +49 (0)4101 304 - 133 (Sales)

Fax: +49 (0)4101 304 - 255 (Order processing)

E-Mail: info.ellerbek@fmcti.com

Web: www.fmctechnologies.com/seningtp

Appendix A. Drawings and Approvals

Title	Nr.	
Copy Master "Measurement Log"		
Depot-TAG Data Acquisition	E51.251458 sh 1	
Depot-TAG Data Acquisition	E51.251458 sh 2	
Principle Diagram - NoMix Loading	E61.351580	
Depot TAG installation (electrical wiring)	E51.351146	
Depot TAG DN100 PN16	E61.251364	
Depot TAG TTMA 4"	E61.251365	
Depot TAG DN80 PN16	E61.251939	
TAG Connection to loading arm (overview)	E51.351624	
TAG Connection to vapour arm (overview)	E51.351625	
TAG Connection to product / vapour recovery hose arm (detail)	E51.351626	
Label	41.351695	
Certificates		
TAG Certificate of Conformity TÜV 02 ATEX 1981	TÜV 02 ATEX 1981	

Table 6: Drawing Overview

Documentation and drawings as PDF files on the Internet:

www.fmctechnologies.com/seningtp

Index

E

EC-Declaration of Conformity45

M

Measurement_Log17, 25

P

Pictograms..... 5

S

Service department 22

V

vapour 7

Measurement Log

Depot <hr/> <hr/> <hr/> <hr/> <hr/>	Installation Company <hr/> <hr/> <hr/> <hr/> <hr/>
---	--

Measurement Point	Description
1	Joint plate of the product / vapour TAG
2	Housing of the product / vapour TAG
3	Product / vapour recovery coupling
Measurement of Resistance	
Measurement between meas. points	The following values must be attained:
1 → 2	R ≥ 10KΩ / ≤ 500KΩ ; value approx. 220kΩ
1 → 3	R < 10 Ω Measurement between the flange isolation of each loading / va-pour recovery arm and the product / vapour recovery coupling.
2 → 2'	R < 10 Ω Measurement between all existing loading / vapour recovery arms

Electrostatic Discharge Resistor / Potential Difference							
Nominal Value	Compartment No.						
10KΩ ≤ R ≤ 500KΩ ca. 220 KΩ	1 → 2	KΩ	KΩ	KΩ	KΩ	KΩ	KΩ
R < 10 Ω	1 → 3	Ω	Ω	Ω	Ω	Ω	Ω

Potential Differenz						
Nominal Value	Product X ↓ Product Y Vapour/Earth					
	↓	↓	↓	↓	↓	↓
R < 10 Ω	2 _X → 2 _{Y/G}	Ω	Ω	Ω	Ω	Ω

Installation Date and Signature:

/

Version 1: TTMA 4" Flange

Version 2: DIN Flange DN100/PN16

possible Position of the Depot-TAG at the flange (free eligible).

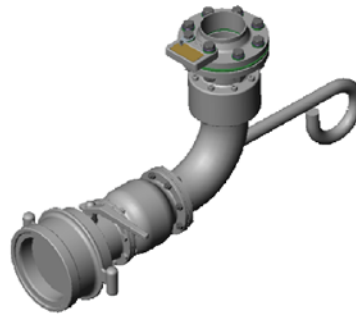
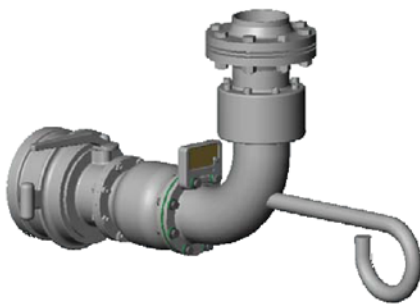

Please fill out table

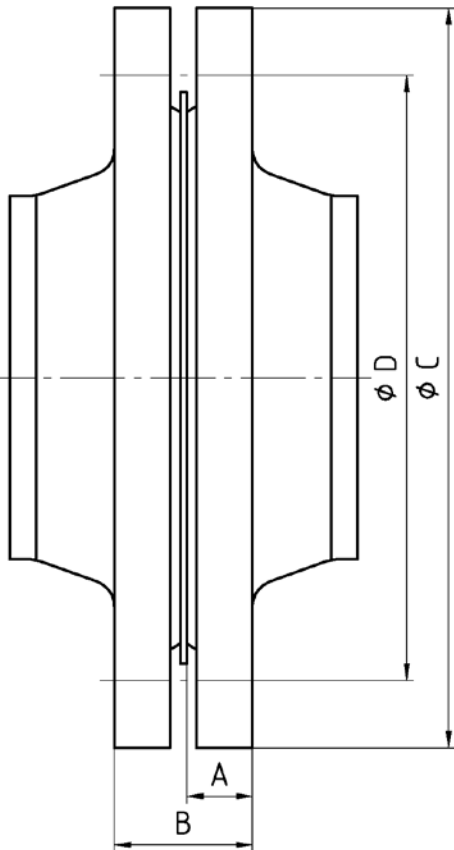

	Version 1	Version 2
Dimension A [mm]:		
Dimension B [mm]:		
Flange ϕ C [mm]:		
Pitch circle of drills ϕ D [mm]:		
Number of holes:		
Size of flange screws:	M	M

Product grade:	Number of TAG's:	
	Version 1	Version 2
Premium unleaded / DL100U		
Premium unleaded / DL99U		
Premium leaded / DL98L		
Premium unleaded / DL98U		
Premium unleaded / DL97U		
Premium unleaded / DL95U		
Gasoline unleaded / DL92U		
Diesel / DLDI		
Ultimate / V-Power Diesel / DLDB		
Truck Diesel / DLDC		
Bio Diesel / DLDI		
Heating fuel / DLHEL		
Ultra low Sulfur Heating fuel / DLHEL5		
Vapour recovery A1+A3 / DVCMA		
Parts for fixation (piece)		

Parts for fixation TTMA 4"	Dimension B [mm]	Parts for fixation DN100 PN16	Dimension B [mm]
DLIS025-T	22 - 27	DLIS030-D	28 - 33
DLIS030-T	28 - 32	DLIS036-D	34 - 39
DLIS035-T	33 - 38	DLIS042-D	40 - 45
		DLIS048-D	46 - 52
		DLIS064-D	61 - 67

Depot	
Location	
Bay No.	

Depot-TAG
Data Acquisition

FMCTechnologies

F.A. Sening GmbH
D-25474 Ellerbek, Germany

Weight : kg	Date : 28.04.2003	Name : Oelting
----------------	----------------------	-------------------

Part-No.

Changed : 11.07.03 Oel.; 19.04.07 Oel. 19.04.04 Oel.; 13.04.06 RL; 12.07.06 Oel.	Drawing No.: E52.251458 Bl.1	Rev.: E
--	---------------------------------	------------

DOK-442E
"Schutzvermerk nach DIN ISO 16016 beachten"

Version 3: DIN Flansch DN80/PN16

possible Position of the Depot-TAG at the flange (free eligible).

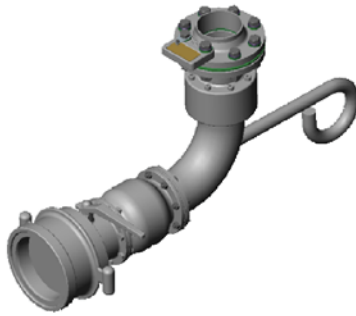

Please fill out table

	Version 3	
Dimension A [mm]:		
Dimension B [mm]:		
Flange ϕ C [mm]:		
Pitch circle of drills ϕ D [mm]:		
Number of holes:		
Size of flange screws:	M	

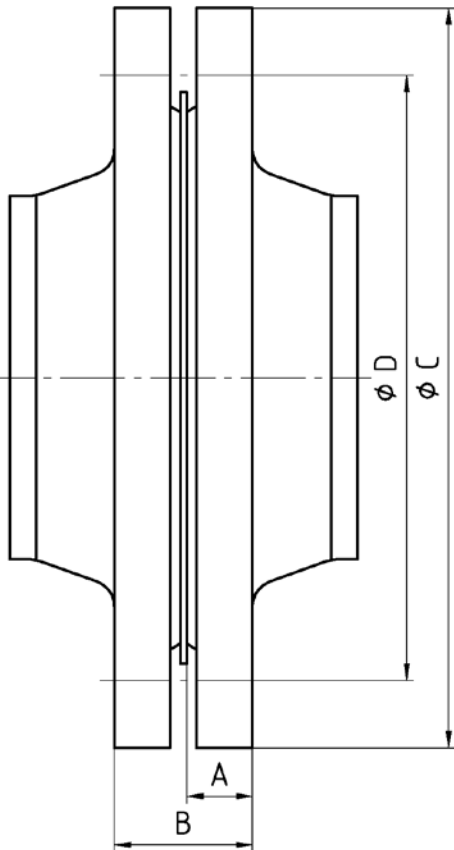

Product grade:	Number of TAG's:	
	Version 3	
Premium unleaded / DL100U		
Premium unleaded / DL99U		
Premium leaded / DL98L		
Premium unleaded / DL98U		
Premium unleaded / DL97U		
Premium unleaded / DL95U		
Gasoline unleaded / DL92U		
Diesel / DLDI		
Ultimate / V-Power Diesel / DLDB		
Truck Diesel / DLDC		
Bio Diesel / DLDI		
Heating fuel / DLHEL		
Ultra low Sulfur Heating fuel / DLHLS		
Vapour recovery A1+A3 / DVCMA		
Parts for fixation (piece)		

Parts for fixation for DN80 PN16	Dimension B [mm]	
DLIS030-D-DN80	28 - 33	
DLIS036-D-DN80	34 - 39	
DLIS042-D-DN80	40 - 45	
DLIS048-D-DN80	46 - 52	
DLIS061-D-DN80	59 - 63	
DLIS0120-D-DN80	118 - 122	

Depot	
Location	
Bay No.	

Depot-TAG
Data Acquisition

FMC Technologies

F.A. Sening GmbH
D-25474 Ellerbek, Germany

Weight : kg	Date : 28.04.2003	Name : Oelting
----------------	----------------------	-------------------

Part-No.

Changed : 19.04.07 Oel.	Drawing No.:	Rev.
	E52.251458 Bl.2	E

DOK-442E
"Schutzvermerk nach DIN ISO 16016 beachten"

Version 3: DIN Flansch DN80/PN16

possible Position of the Depot-TAG at the flange (free eligible).

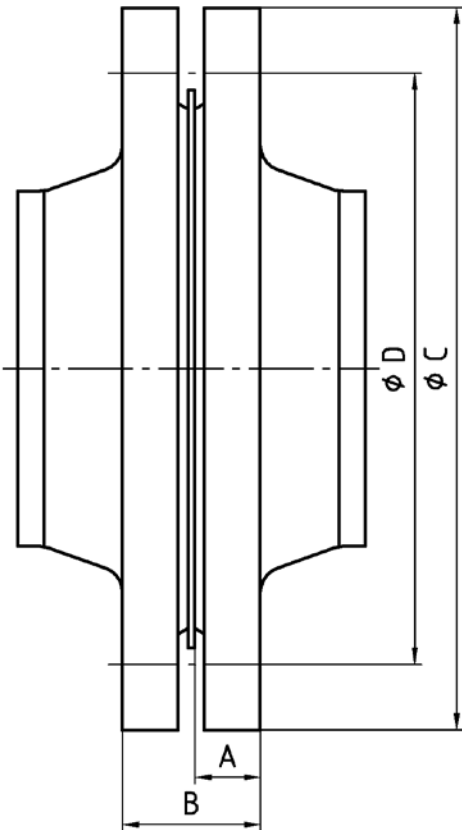

Please fill out table

	Version 1
Dimension A [mm]:	
Dimension B [mm]:	
Flange ϕ C [mm]:	
Pitch circle of drills ϕ D [mm]:	
Number of holes:	
Size of flange screws:	M
Product grade:	Number of TAG's:
	Version 1
Premium unleaded / DL100U	
Premium unleaded / DL99U	
Premium leaded / DL98L	
Premium unleaded / DL98U	
Premium unleaded / DL97U	
Premium unleaded / DL95U	
Gasoline unleaded / DL92U	
Diesel / DLDI	
Ultimate / V-Power Diesel / DLDB	
Diesel Low Sulfur / DLDC	
Bio Diesel / DLDD	
Truck Diesel / DLDE	
Bio Diesel (5-20%) / DLDF	
Heating Oil / DLHEL	
Synthetic Heating Oil / DLHELs	
Low Sulfur Heating Oil / DLHELLS	
Kerosene / DLKF	
E10 / DLE10	
E50 / DLE50	
E85 / DLE85	
Vapour recovery A1+A3 / DVCMA	
Parts for fixation (piece)	

Parts for fixation for DN80 PN16	Dimension B [mm]
DLIS030-D-DN80	28 - 33
DLIS036-D-DN80	34 - 39
DLIS042-D-DN80	40 - 45
DLIS048-D-DN80	46 - 52
DLIS061-D-DN80	59 - 63
DLIS0120-D-DN80	118 - 122

Depot	
Location	
Bay No.	

Depot-TAG
Data Acquisition
Flange DN80/PN16

FMC Technologies

F.A. Sening GmbH
D-25474 Ellerbek, Germany

Weight : kg	Date : 28.04.2003	Name : Oelting
----------------	----------------------	-------------------

Part-No.

Changed: FCN No. Date Name	Drawing No.:	Rev.
26.06.07 RL:	E54.251458 Bl.3 H	
20050 18.10.07 RL:		
29.04.08 RL:		

DOK-442E "Schutzvermerk nach DIN ISO 16016 beachten"

Version 2: DIN Flange DN100/PN40

possible Position of the Depot-TAG at the flange (free eligible).

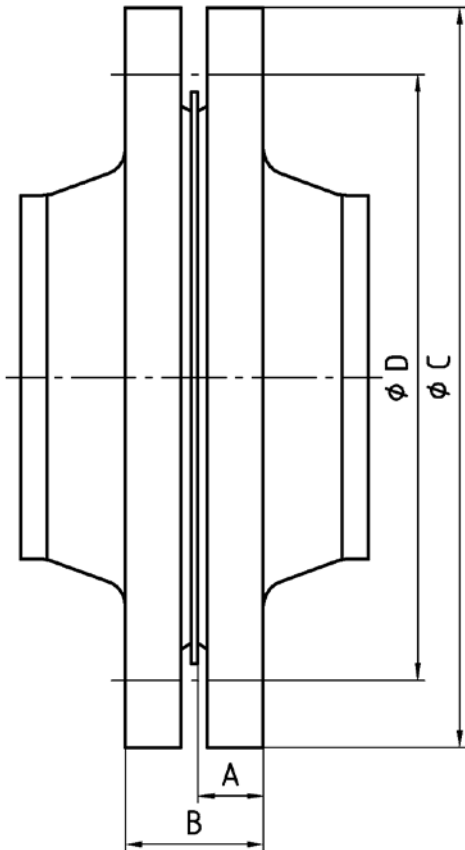
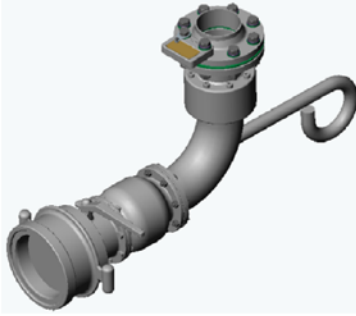

Please fill out table

	Version 1
Dimension A [mm]:	
Dimension B [mm]:	
Flange ϕ C [mm]:	
Pitch circle of drills ϕ D [mm]:	
Number of holes:	
Size of flange screws:	M

Product grade:	Number of TAG's:
	Version 1
Premium unleaded / DL100U	
Premium unleaded / DL99U	
Premium leaded / DL98L	
Premium unleaded / DL98U	
Premium unleaded / DL97U	
Premium unleaded / DL95U	
Gasoline unleaded / DL92U	
Diesel / DLDI	
Ultimate / V-Power Diesel / DLDB	
Diesel Low Sulfur / DLDC	
Bio Diesel / DLDD	
Truck Diesel / DLDE	
Bio Diesel (5-20%) / DLDF	
Heating Oil / DLHEL	
Synthetic Heating Oil / DLHELs	
Low Sulfur Heating Oil / DLHELLS	
Kerosene / DLKF	
E10 / DLE10	
E50 / DLE50	
E85 / DLE85	
Vapour recovery A1+A3 / DVCMA	
Parts for fixation (piece)	

Parts for fixation DN100 PN40	Dimension B [mm]		
DLIS052-DN100PN40	50 - 54		

Depot	
Location	
Bay No.	

DOK-442E "Schutzvermerk nach DIN ISO 16016 beachten"

Depot-TAG
Data Acquisition
Flange DN100/PN40

FMC Technologies

F.A. Sening GmbH
D-25474 Ellerbek, Germany

Weight :	Date :	Name :
kg	31.10.2007	Larsen

Part-No.

Changed:	ECN No.	Date	Name	Drawing No.:	Rev.
		29.04.08	RL:	E54.251458	BL4 H

E61.351580 - Principle Diagram - NoMix Loading

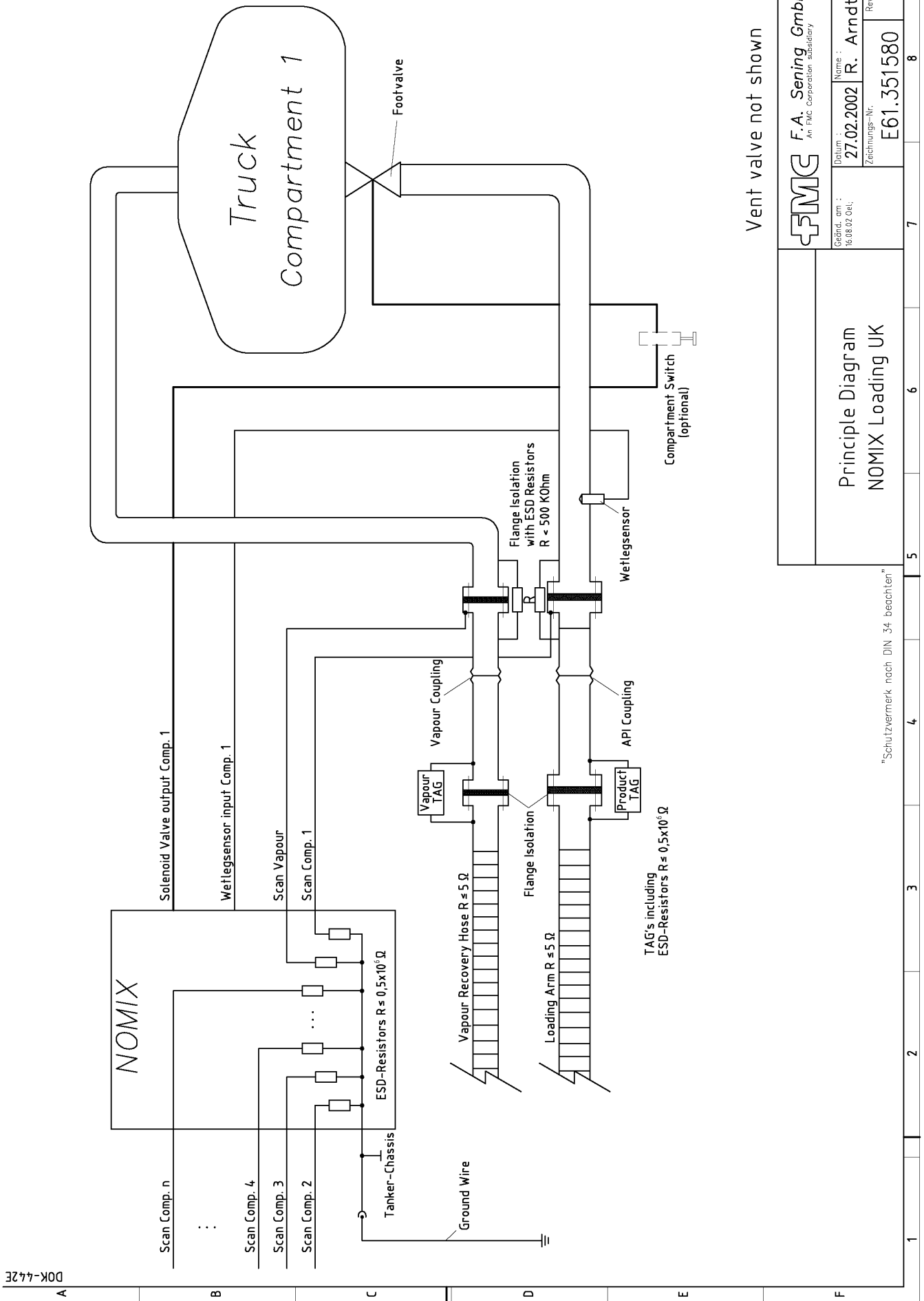

Vent valve not shown

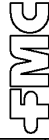
 F.A. Sening GmbH <small>An FMC Corporation subsidiary</small>		Name : R. Arndt	
		Datum : 27.02.2002	Zeichnungs-Nr. E61.351580
Geänd. am : 16.08.02 Oel;		Rev.	
Principle Diagram NOMIX Loading UK		7	8

"Schutzvermerk nach DIN 34 beachten"

E51.351146 - Depot TAG installation (electrical wiring)

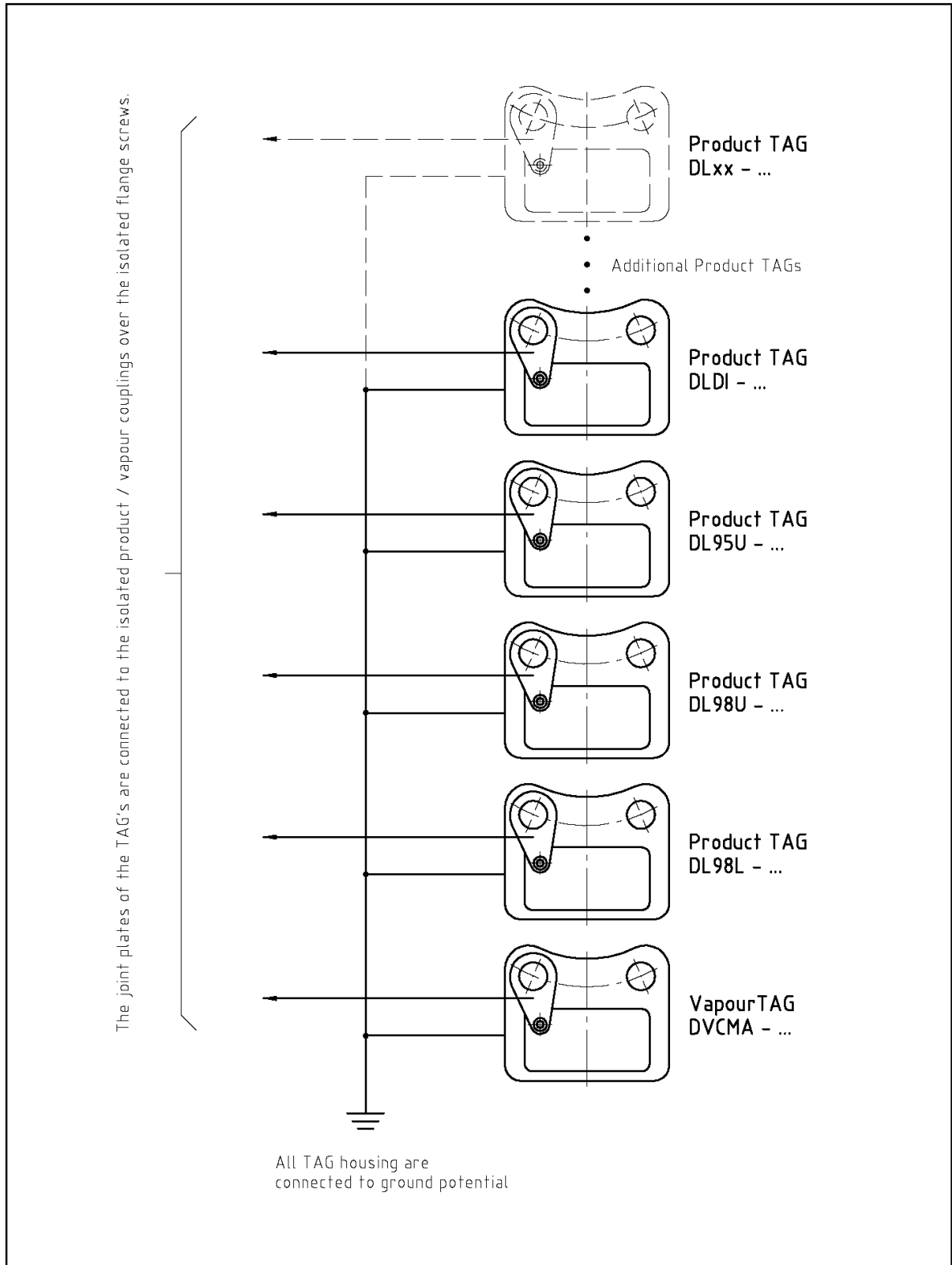

DOK-442E
"Schutzvermerk nach DIN 34 beachten"

Depot-TAG Installation

-Electrical wiring-



F.A. Sening GmbH
An FMC Corporation subsidiary

Geänd. am :
26.03.02 NB;
24.04.03 Oel;

Datum :
09.02.1999

Name :
R. Arndt

Zeichnungs-Nr.
E51.351146

Rev.
A

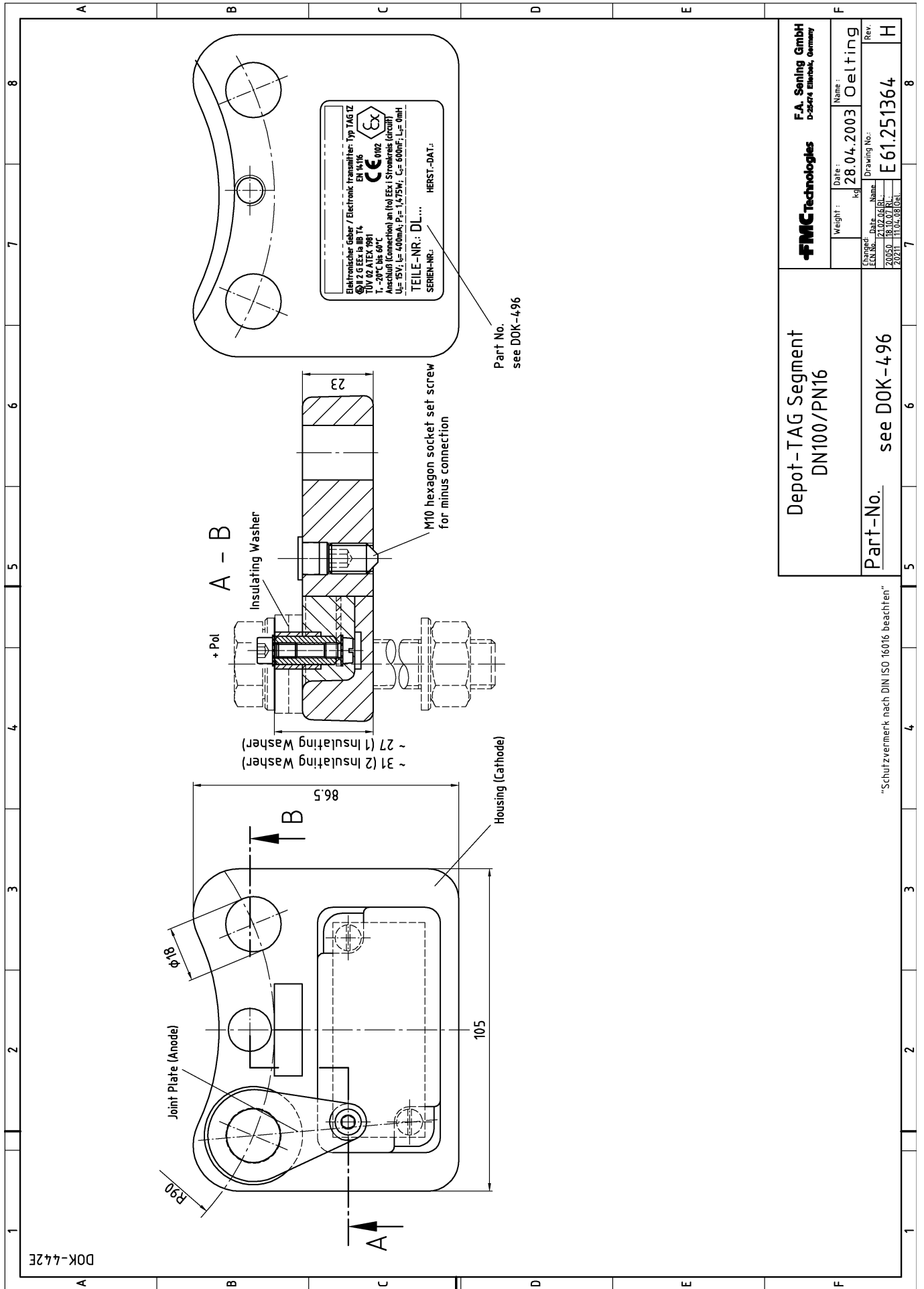

Part No.
see DOK-496

Depot-TAG Segment
DN100/PN16

FMC Technologies
F.A. Sening GmbH
D-30455 Elmshorn, Germany

Weight:	Date:	Name:
kg	28.04.2003	Oelting
Change:	Date:	Name:
21.02.06 RL		
20050_18.10.07 RL		
2021_11.04.08 DEL		
Drawing No.:	E 61.251364	
Rev.:	H	

Part-No. see DOK-496

"Schutzvermerk nach DIN ISO 16016 beachten"

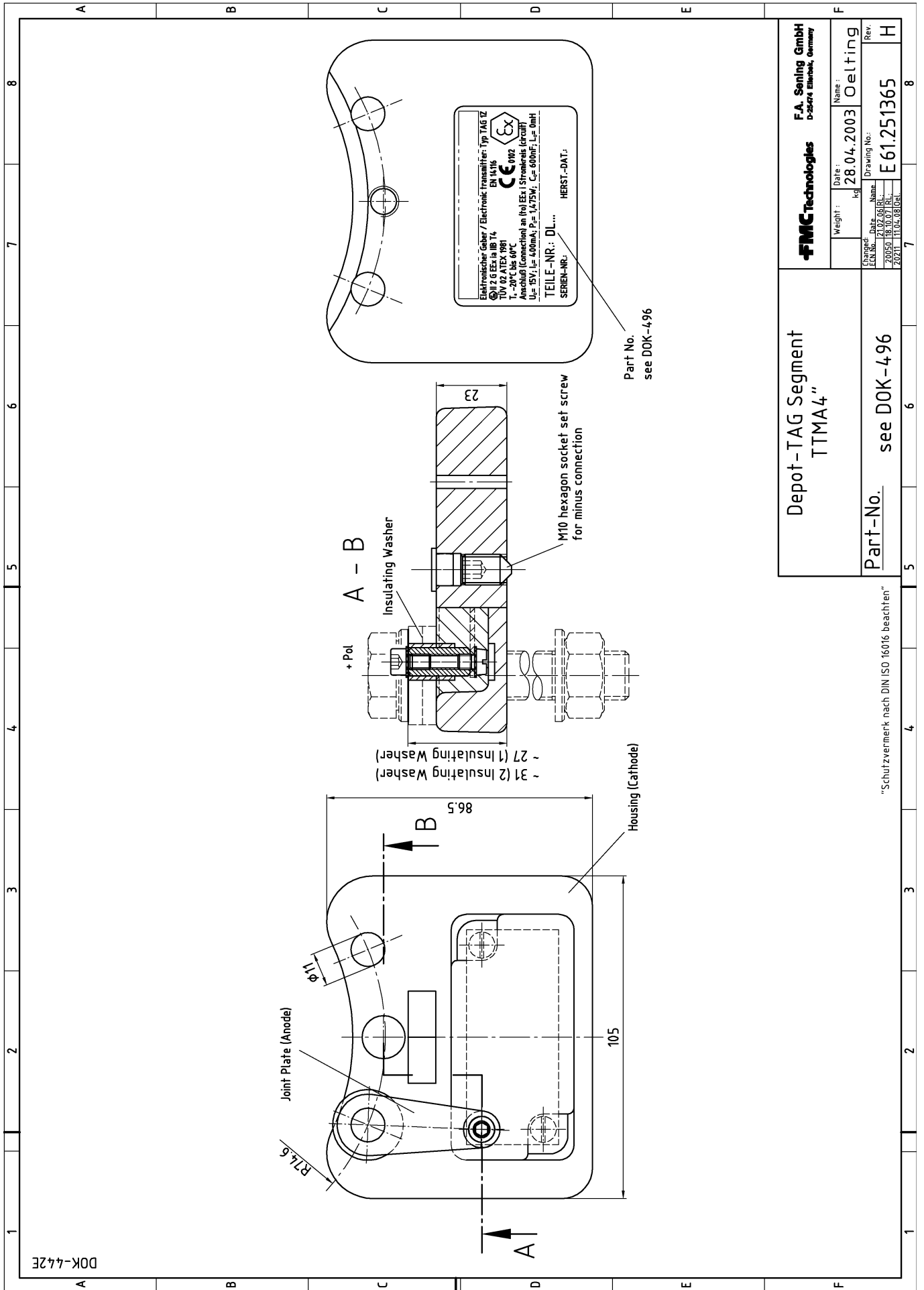

F.A. Sening GmbH D-30455 Elmstedt, Germany		Weight:	Date:	Name:
		kg	28.04.2003	Oelting
Depot-TAG Segment TTMA 4"		Change:	Date:	Name:
		21.02.09 RL	20.05.18:0.07 RL	2021: IT104.08.06L
Part-No. see DOK-496		Drawing No.: E 61.251365		Rev.: H

"Schutzvermerk nach DIN ISO 16016 beachten"

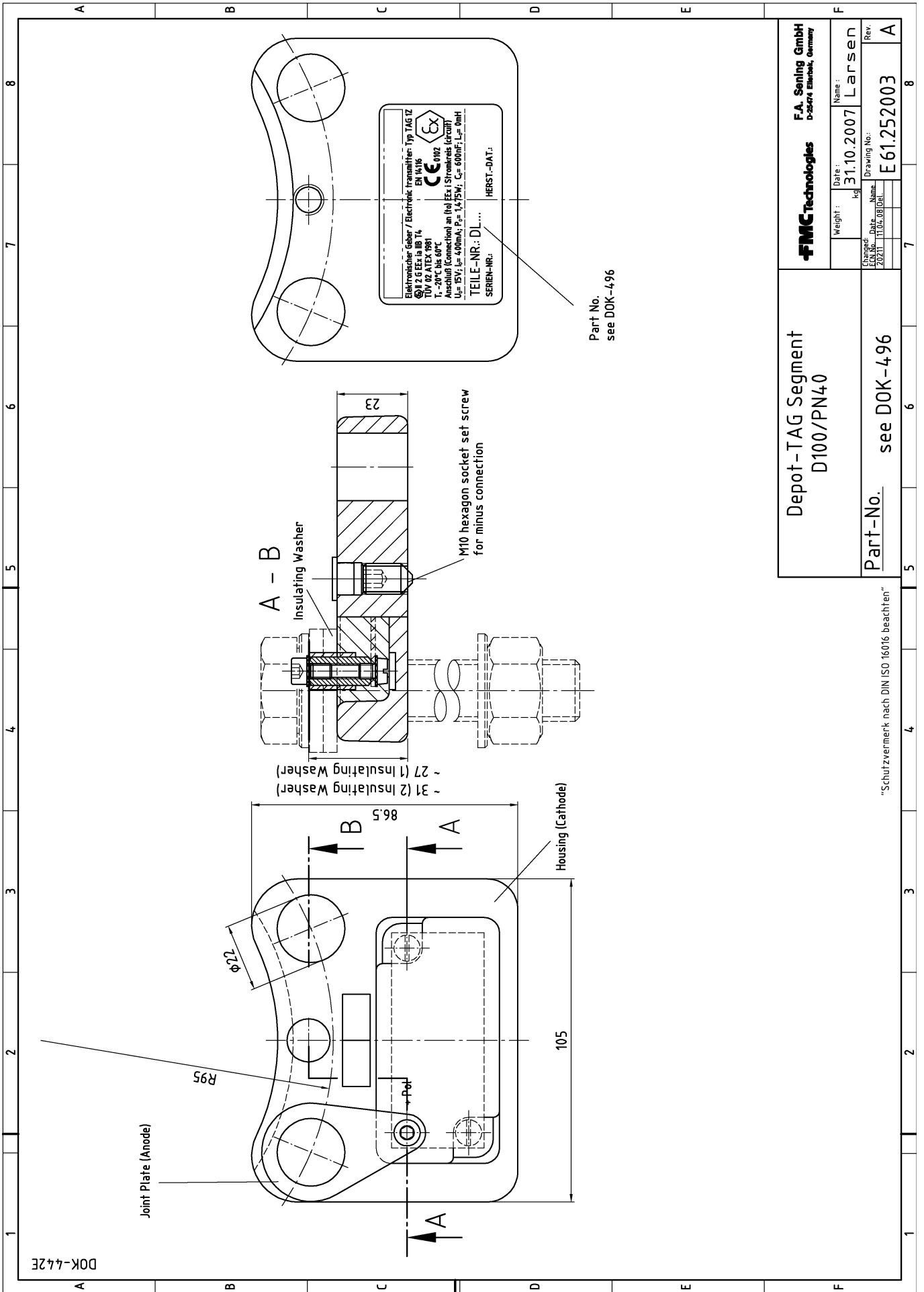

F.M.C. Technologies F.A. Sening GmbH D-30854 Elmek, Germany		Weight:	Date:	Name:
		kg	31.10.2007	Larsen
Depot-TAG Segment D100/PN40		Change:	Date:	Name:
Part-No. see DOK-496		70211	11.04.08	DL
"Schutzvermerk nach DIN ISO 16016 beachten"		Drawing No.: E 61.252003		Rev. A

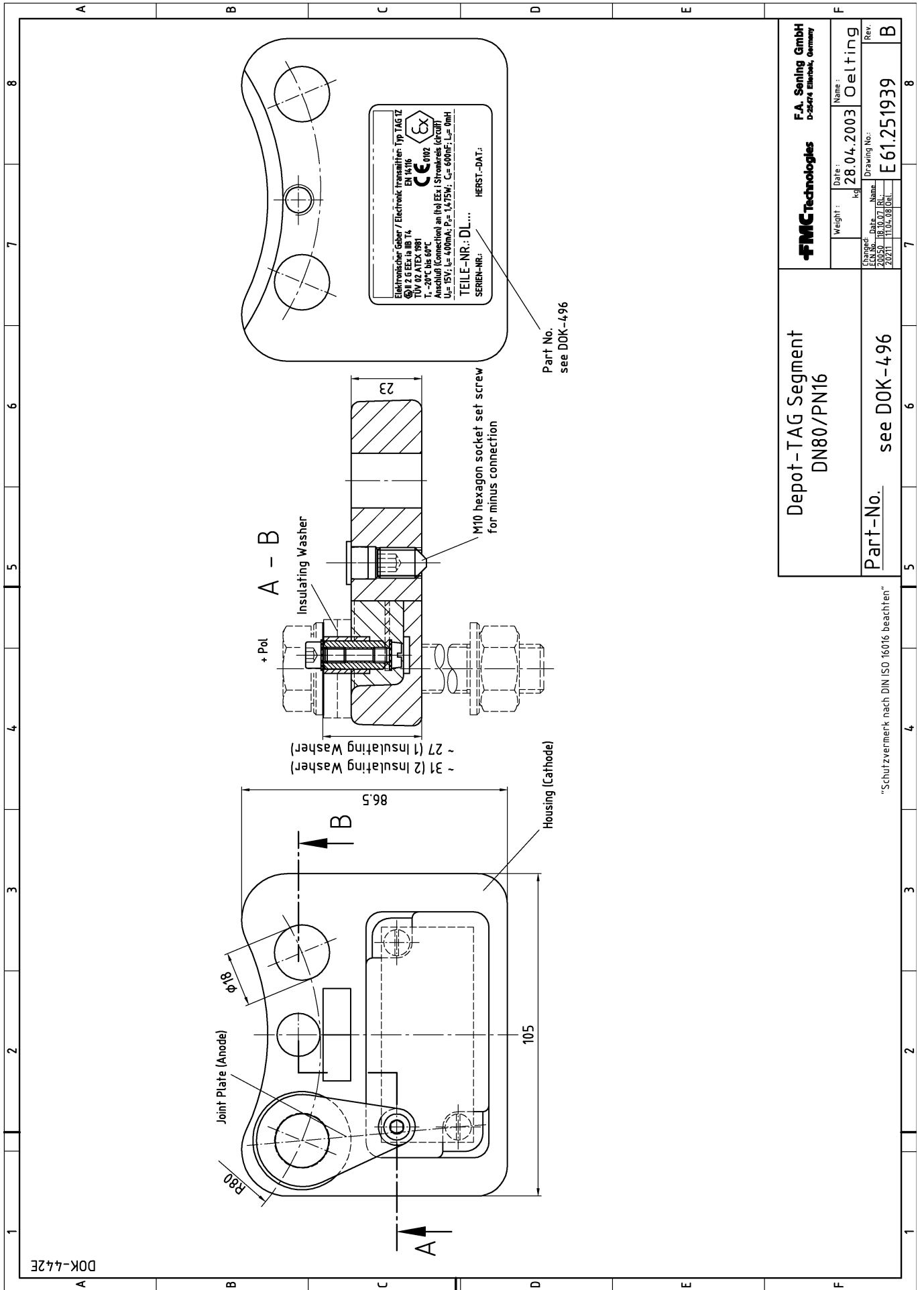

F.M.C. Technologies F.A. Sening GmbH D-30854 Elmek, Germany		Weight:	Date:	Name:
		kg	28.04.2003	Oelting
Depot-TAG Segment DN80/PN16		Change:	Date:	Name:
		20030	18.10.07	RL
Part-No. see DOK-496		Drawing No.:	E 61.251939	
		Rev.:	B	

"Schutzvermerk nach DIN ISO 16016 beachten"

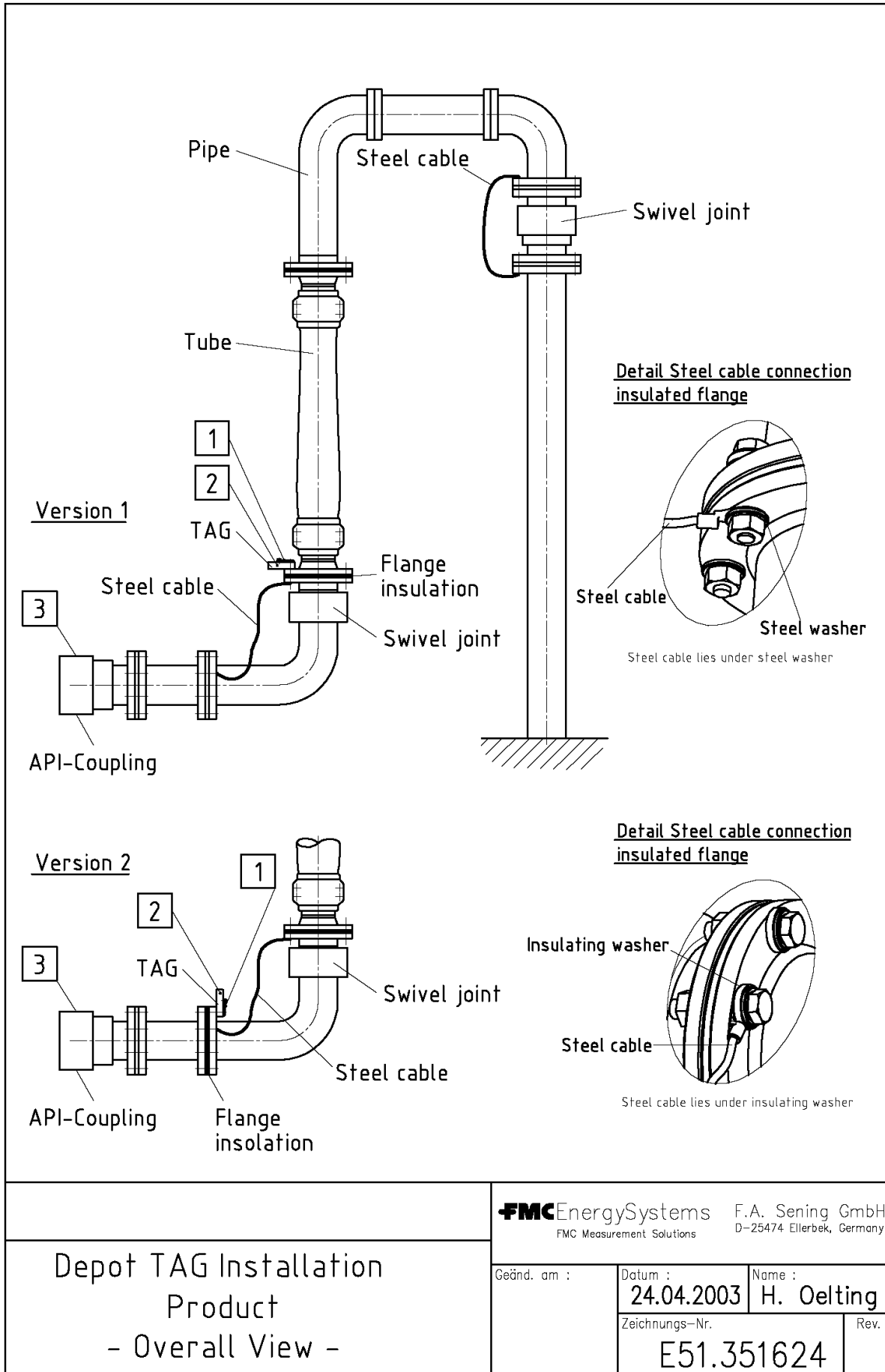

DOK-442E
"Schutzvermerk nach DIN 34 beachten"

E51.351625 - TAG Connection to vapour arm (overview)

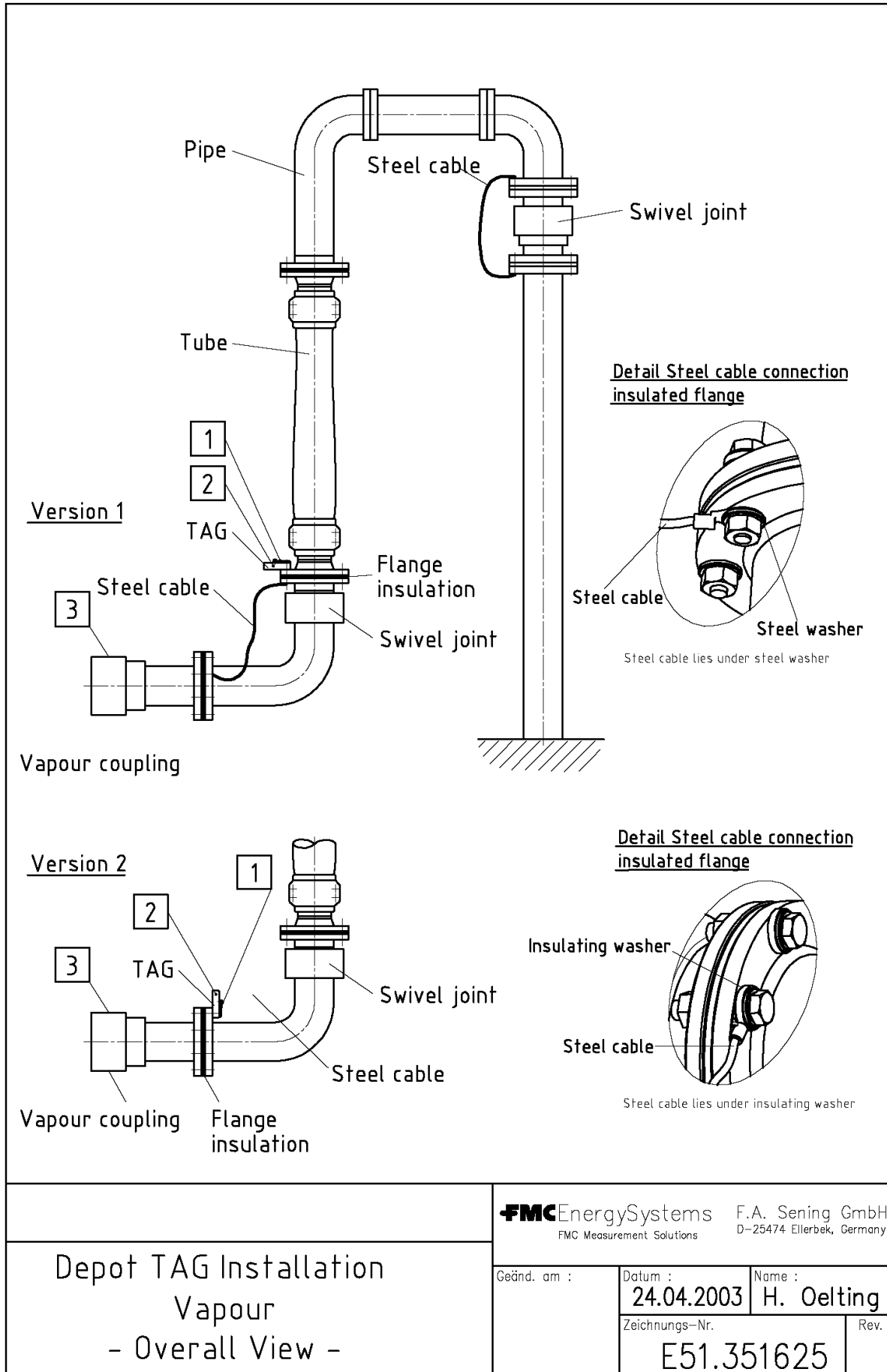

DOK-442E
"Schutzvermerk nach DIN 34 beachten"

Depot TAG Installation
Vapour
- Overall View -

FMCEnergySystems F.A. Sening GmbH
FMC Measurement Solutions D-25474 Ellerbek, Germany

Geänd. am :	Datum :	Name :
	24.04.2003	H. Oelting
Zeichnungs-Nr.		Rev.
E51.351625		

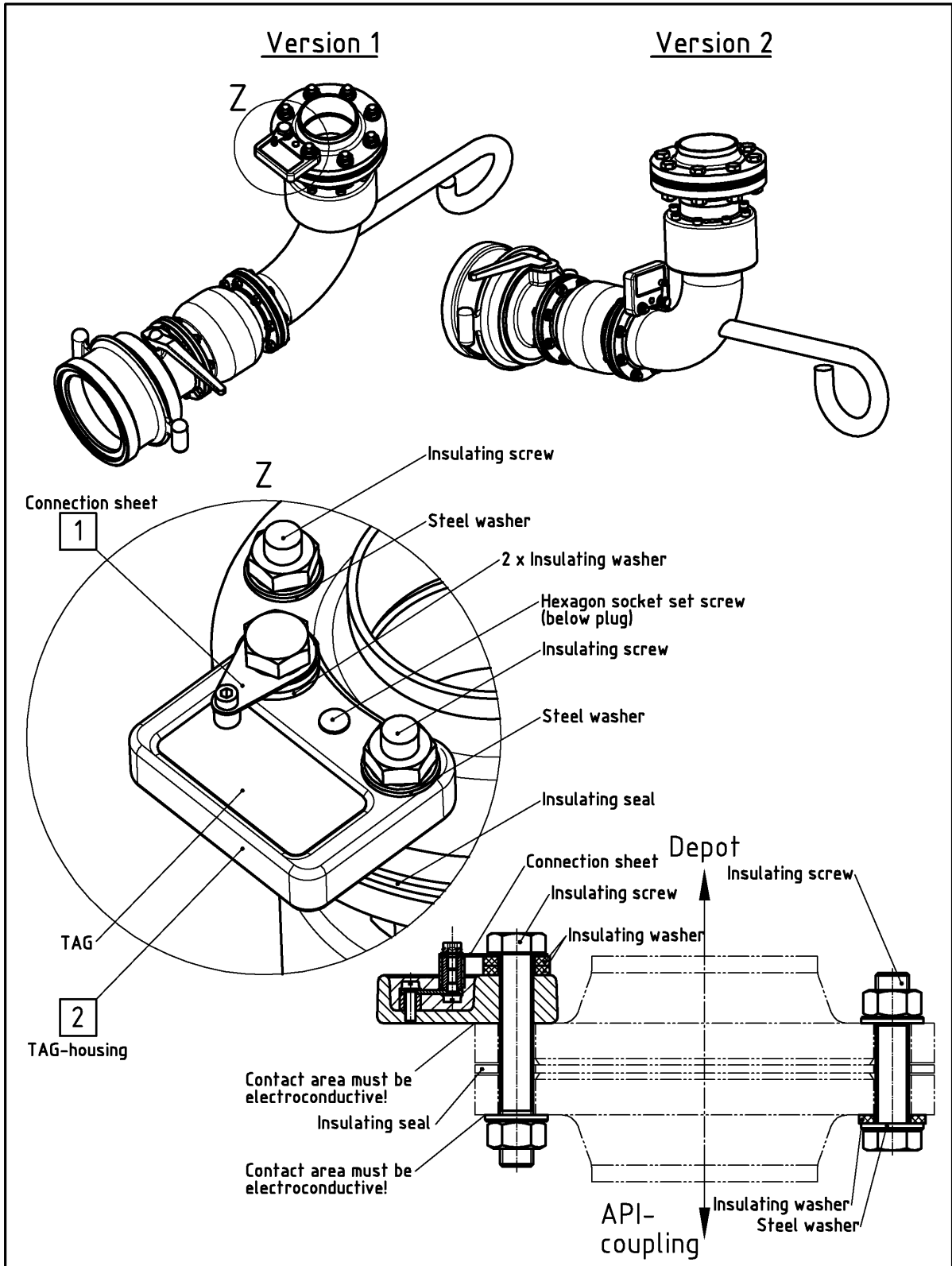

DOK-442E
"Schutzvermerk nach DIN 34 beachten"

Depot TAG Installation
Product / Vapour
- Detail -

FMC Technologies

F.A. Sening GmbH
D-25474 Ellerbek, Germany

Changed :		Date :	Name :
ECN No.	Date	28.04.2003	Oelting
2021	11.04.08	Oel.	
Drawing No.			Rev.
E51.351626			A

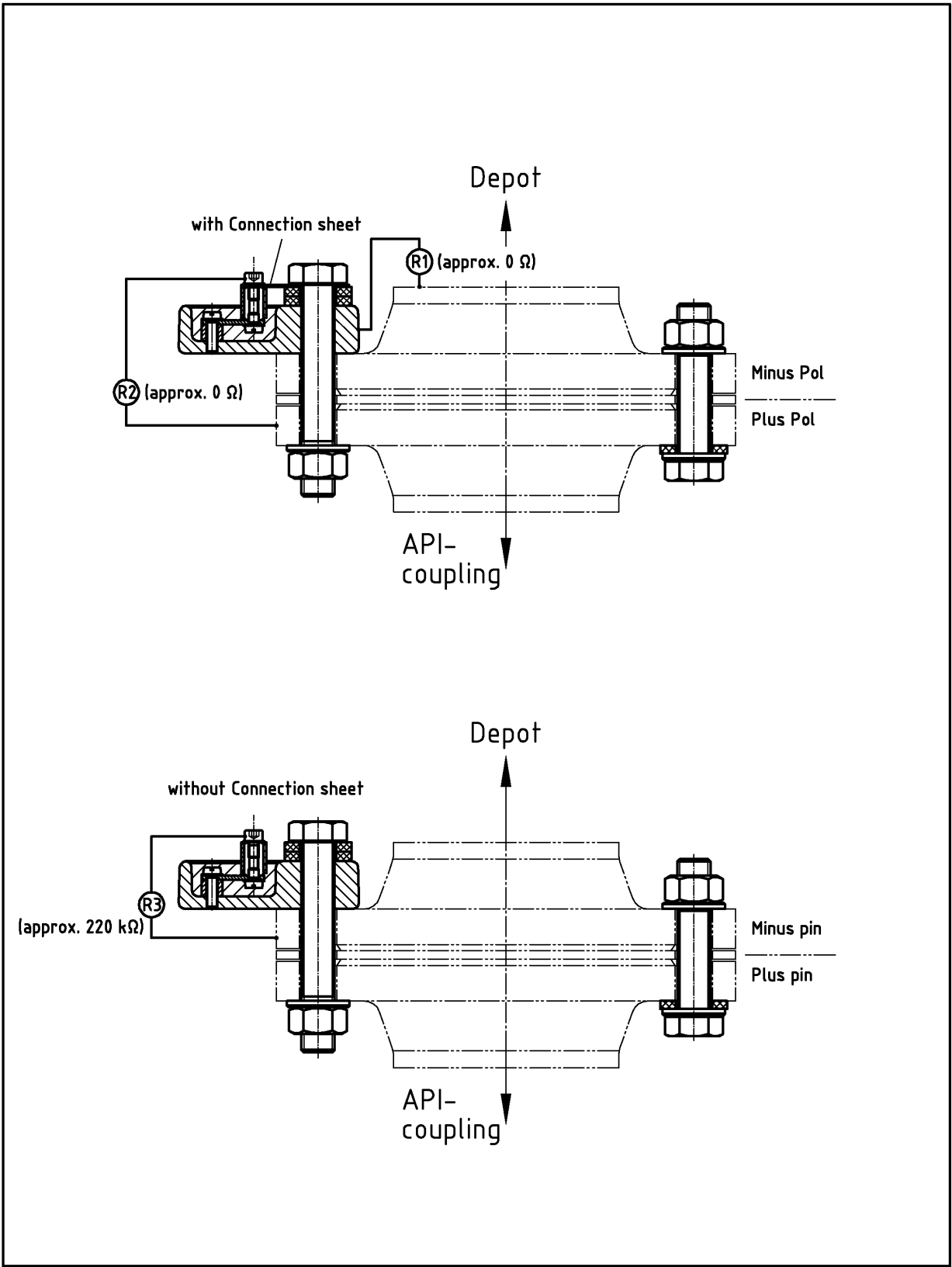

DOK-442
"Schutzvermerk nach DIN 34 beachten"

Depot TAG Installation Product / Vapour Measuring of bleeder resistance		FMC Technologies		F.A. Sening GmbH D-25474 Ellerbek, Germany			
		Changed : ECN No. Date Name 20211 11.04.08 Det:		Date : 26.06.2002		Name : Oelting	
				Drawing No. E 52.351626		Rev. Bl.2 A	

EG - Konformitätserklärung
EC - Declaration of Conformity

im Sinne der EG-Richtlinie über explosionsgeschützte Geräte
nach 94/9/EG (ATEX)
as defined by non-electrical explosion protected Equipment Directive 94/9/EC

Der Hersteller / *The manufacturer*

F.A. Sening GmbH, Regentstraße 1, D-25474 Ellerbek

erklärt hiermit, dass das (die) explosionsgeschützte(n) Gerät(e)
herewith we declare, that the explosion protected equipment

	Produktbezeichnung: <i>Product:</i>	Zündschutzart: <i>Type of protection:</i>	EG – Baumusterbescheinigung* <i>EC – Type Test Approval</i>
1.	Elektronische Geber Typ: TAG 1.-...	 II 2 G EEx ia IIB T4	TÜV 02 ATEX 1981

einschließlich aller Ergänzungen / including all supplements

in der gelieferten Ausführung den folgenden Sicherheitsanforderungen entspricht (entsprechen):
Corresponds to following safety requirements in the delivered implementation:

Grundlegende Normen / CENELEC: EN 50 014: 1997 + A1 + A2, EN 50 020:1994 +
Basic norms: 2002

Angewandte harmonisierte Normen, insbesondere: EN 14116
Applied harmonized standards, in particular:

Andere angewandte Bestimmungen / EG-Richtlinien:
Other applied appointments / EC-Directives:

Benannte Stelle / Produktionsüberwachung: Physikalisch-Technische Bundesanstalt
Notified Body Production control PTB 99 ATEX Q001; CE 0102

Prüfungen/Überwachung/Kontrollen während der Fertigung: Hersteller
Examination/inspection/tests during manufacturing: *Manufacturer*

Die zugehörige Betriebsanleitung enthält wichtige sicherheitstechnische Hinweise und Vorschriften für die
Aufstellung, Inbetriebnahme, Wartung und Instandhaltung der (s) Gerät(es).
*The appropriate operator's manual contains important safety technical notes and regulations for the installation, placing into
operation, maintenance and maintenance of the equipment.*

Ort und Datum: Ellerbek, den 18.01.2008
Location and date

Geschäftsführer
General Manager

(H. Short)

The specifications contained herein are subject to change without notice and any user of said specifications should verify from the manufacturer that the specifications are currently in effect. Otherwise, the manufacturer assumes no responsibility for the use of specifications which may have been changed and are no longer in effect.

Contact information is subject to change. For the most current contact information, visit our website at www.fmctechnologies.com/measurementsolutions and click on the "Contact Us" link in the left-hand column.

Headquarters:

500 North Sam Houston Parkway West, Suite 100 Houston, TX 77067 USA, Phone: +1 (281) 260 2190, Fax: +1 (281) 260 2191

Measurement Products and Equipment:

Erie, PA USA +1 (814) 898 5000

Ellerbek, Germany +49 (4101) 3040

Barcelona, Spain +34 (93) 201 0989

Beijing, China +86 (10) 6500 2251

Buenos Aires, Argentina +54 (11) 4312 4736

Burnham, England +44 (1628) 603205

Dubai, United Arab Emirates +971 (4) 883 0303

Los Angeles, CA USA +1 (310) 328 1236

Melbourne, Australia +61 (3) 9807 2818

Moscow, Russia +7 (495) 5648705

Singapore +65 6861 3011

Integrated Measurement Systems:

Corpus Christi, TX USA +1 (361) 289 3400

Kongsberg, Norway +47 (32) 28 67 00

San Juan, Puerto Rico +1 (787) 772 8100

Dubai, United Arab Emirates +971 (4) 883 0303

Visit our website at www.fmctechnologies.com/measurementsolutions

Printed in Germany © 03/15 F. A. Sening GmbH, Inc. All rights reserved. MN F16 003 EN / DOK-442E Issue/Rev. 1.24 (06/08)