

Valve Linkage Assembly

(For use with Veeder-Root Preset Counter only. For Smith-style Preset Counter Linkage, see Form No. P0303.*)

Standard Meter: 538908-1
Angle Meter: 538909-1

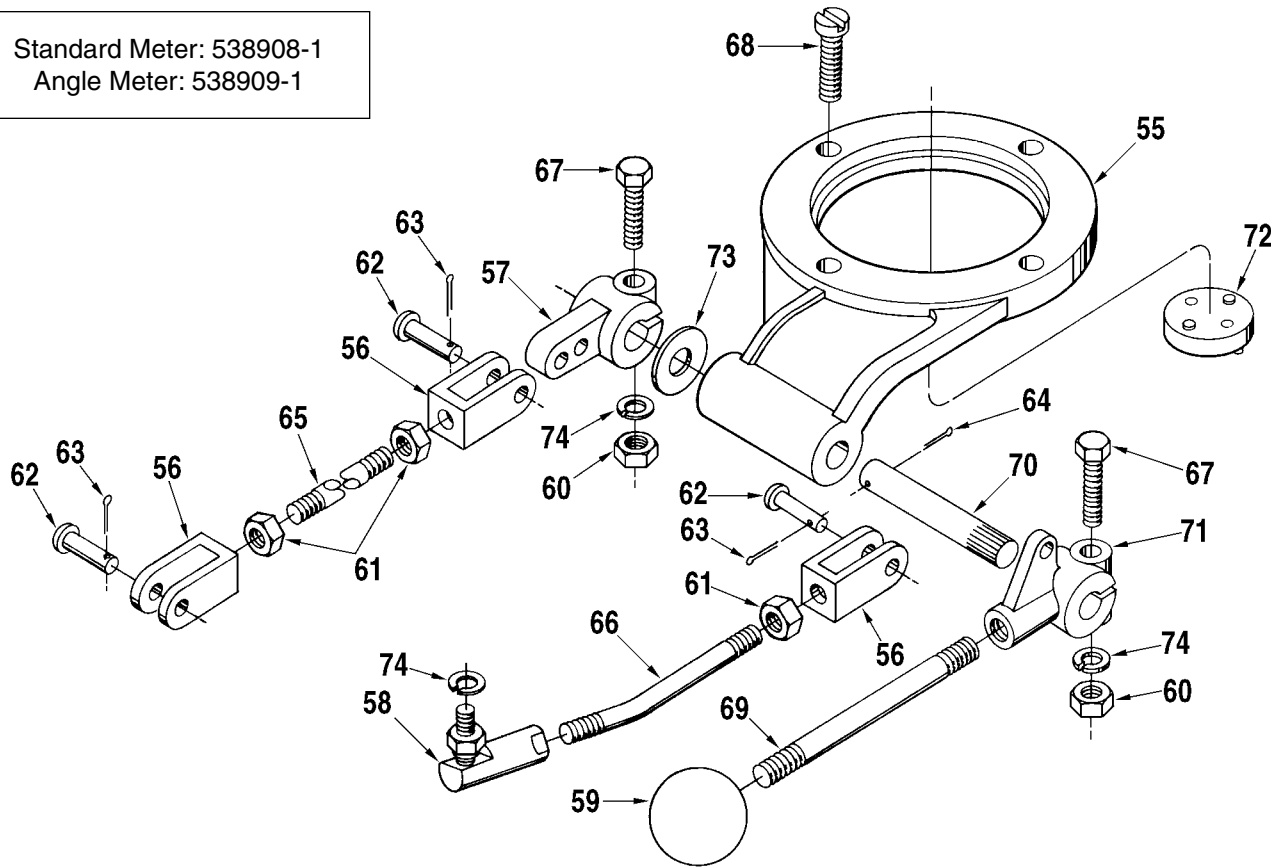

| Item | Description | Qty. | Part Number |
|------|--|------|-------------|
| 1 | R Adjuster, Needle Valve: Buna-N Trim | 1 | 518814-001 |
| | Viton Trim | 1 | 518814-002 |
| 2 | Cup, Adjuster..... | 1 | 518818-001 |
| 3 | + Gland..... | 1 | 518817-001 |
| 4 | R+ O-Ring: Buna-N | 1 | 642586-406 |
| | Viton..... | 1 | 640798-433 |
| 5 | Pin, Roll, 1/16 x 1/2"..... | 1 | 015129-400 |
| 6 | Pin, Roll, 1/16 x 7/16"..... | 1 | 642431-404 |
| 7 | Ring, Retaining..... | 1 | 640822-407 |
| 8 | Spring..... | 1 | 518821-001 |
| 9 | Stem..... | 1 | 518820-001 |
| 10 | R Washer, .194 x .744"..... | 1 | 518819-001 |
| 11 | R Washer, 17/64 x 7/16" Flat..... | 1 | 640652-001 |
| 12 | Blind, Gland Opening | 1 | 011941-001 |
| 13 | Body: Cast Iron | 1 | 518920-003 |
| | Steel, Class 150..... | 1 | 518920-004 |
| | Steel, Class 300..... | 1 | 518920-005 |
| 14 | Bushing | 2 | 518912-001 |
| 15 | + Bushing, Gland Shaft | 1 | 503685-001 |
| 16 | Collar, Shaft Lever | 1 | 503681-001 |
| 17 | Cone, End | 1 | 013230-001 |

| Item | Description | Qty. | Part Number |
|------|--|------|-------------|
| 18 | Cylinder: | | |
| | Cast Iron | 1 | 518838-001 |
| | Steel..... | 1 | 518838-002 |
| 19 | Expander, Piston Ring..... | 1 | 518840-001 |
| 20 | + Gasket, Gland Cover | 2 | 011940-001 |
| 21 | Lever, Operating..... | 1 | 550459-001 |
| 22 | Lever, Valve | 1 | 550644-001 |
| 23 | Nut: | | |
| | Steel, Class 300 Model, 3/4"-10 | 8 | 006985-002 |
| | Cast Iron and Steel, Class 150 Models, 5/8"-11 | 4 | 004557-400 |
| 24 | Nut, Operating Lever, 1/4"-28 | 1 | 002077-400 |
| 25 | R+ O-Ring: | | |
| | Buna-N..... | 1 | 640913-003 |
| | Viton..... | 1 | 641276-403 |
| 26 | R+ O-Ring: | | |
| | Buna-N..... | 1 | 641070-416 |
| | Viton..... | 1 | 641276-413 |
| 27 | Pin, Groove, 1/8 x 3/4" | 1 | 006127-002 |
| 28 | R Piston and Cone: | | |
| | Buna-N..... | 1 | 518911-001 |
| | Viton..... | 1 | 518911-002 |
| 29 | Cone..... | 1 | 502734-001 |
| 30 | Piston | 1 | 518837-001 |
| 31 | R+ Ring, Valve: | | |
| | Buna-N | 1 | 012611-001 |
| | Viton..... | 1 | 511004-001 |
| 32 | Screw, 5/16-24 x 2" | 3 | 060454-006 |
| 33 | R Seat, Ball..... | 1 | 014068-001 |
| 34 | Shaft..... | 1 | 014072-001 |
| 35 | Spring..... | 1 | 012617-001 |
| 36 | R Valve, Pilot: | | |
| | Buna-N | 1 | 072099-001 |
| | Viton..... | 1 | 511670-001 |
| 37 | Plug, Pipe, 1/4" NPT..... | 1 | 002407-402 |
| 38 | Retainer, Thrust..... | 1 | 503682-001 |
| 39 | Ring, Piston | 2 | 518839-001 |
| 40 | Screw, 5/16-24 x 7/8" | 4 | 006283-002 |
| 41 | Screw, #8-32 x 3/8" | 2 | 006293-002 |
| 42 | Screw, 1/4-28 x 1/2" | 2 | 060316-002 |
| 43 | Screw, 1/4-28 x 1-1/4" | 1 | 009934-400 |
| 44 | Screw, Set, 5/16-18 x 1/2" | 3 | 065425-002 |
| 45 | Shaft, Lever | 1 | 012608-001 |
| 46 | Spring, Gland Washer | 1 | 503684-001 |
| 47 | Spring, Piston..... | 1 | 012618-001 |
| 48 | Stud: | | |
| | Steel, Class 300 Model..... | 8 | 640528-001 |
| | Cast Iron and Steel, Class 150 Models | 4 | 642363-405 |
| 49 | R Valve, Needle | 1 | 518822-001 |
| 50 | Valve, Tappet | 1 | 072094-001 |
| 51 | Washer | 2 | 009615-400 |
| 52 | Washer, Gland..... | 1 | 503683-001 |
| 53 | Washer, Lock..... | 2 | 009831-400 |
| 54 | Washer, Lock Spring | 1 | 002069-400 |

| Item | Description | Qty. | Part Number |
|-------------------------------|---|------|-------------|
| Valve Linkage Assembly | | | |
| 55 | Adapter, Control Lever..... | 1 | 518381-001 |
| 56 | + Clevis..... | 3 | 013192-001 |
| 57 | Crank..... | 1 | 518379-001 |
| 58 | Joint, Ball..... | 1 | 643134-402 |
| 59 | Knob..... | 1 | 006660-001 |
| 60 | Nut, 1/4"-28..... | 2 | 002077-400 |
| 61 | Nut, 5/16"-24..... | # | 005292-400 |
| 62 | + Pin, Clevis..... | 3 | 644513-401 |
| 63 | Pin, Cotter, 1/16 x 3/8"..... | 6 | 009825-400 |
| 64 | Pin, Cotter, 3/32 x 1-1/4" (Angle Meters Only)..... | 1 | 006373-001 |
| 65 | Rod, Tie (Specify Length)..... | 1 | 013193-001 |
| 66 | Rod, Tie..... | 1 | 538910-001 |
| 67 | Screw, 1/4-28 x 1-1/4"..... | 2 | 009934-400 |
| 68 | Screw, 3/8-16 x 1-1/2"..... | 2 | 060452-002 |
| 69 | Shaft, Handle..... | 1 | 518640-001 |
| 70 | Shaft, Valve Control: | | |
| | Straight-Through Meter..... | 1 | 518639-001 |
| | Angle Meter..... | 1 | 519369-001 |
| 71 | Socket, Crank, and Handle..... | 1 | 518377-002 |
| 72 | Spacer, Drive Coupling..... | 1 | 533020-001 |
| 73 | Washer (Angle Meters Only)..... | 1 | 065309-002 |
| 74 | Washer, 1/4" Lock Spring..... | 3 | 002069-400 |

+ Recommended stock.

Order quantity required.

* The latest edition is indicated by a 2-digit postscript (e.g., .01, .02, etc.).

Revisions included in P1062.01 Issue/Rev. 0.1 (7/11):

Removed EPR and Teflon from parts listing.

The specifications contained herein are subject to change without notice and any user of said specifications should verify from the manufacturer that the specifications are currently in effect. Otherwise, the manufacturer assumes no responsibility for the use of specifications which may have been changed and are no longer in effect.

Contact information is subject to change. For the most current contact information, visit our website at www.fmctechnologies.com/measurementsolutions and click on the "Contact Us" link in the left-hand column.

Headquarters:

500 North Sam Houston Parkway West, Suite 100, Houston, TX 77067 USA, Phone: +1 (281) 260 2190, Fax: +1 (281) 260 2191

Measurement Products and Equipment:

Erie, PA USA +1 (814) 898 5000

Ellerbek, Germany +49 (4101) 3040

Barcelona, Spain +34 (93) 201 0989

Beijing, China +86 (10) 6500 2251

Buenos Aires, Argentina +54 (11) 4312 4736

Burnham, England +44 (1628) 603205

Dubai, United Arab Emirates +971 (4) 883 0303

Los Angeles, CA USA +1 (310) 328 1236

Melbourne, Australia +61 (3) 9807 2818

Moscow, Russia +7 (495) 5648705

Singapore, +65 6861 3011

Integrated Measurement Systems:

Corpus Christi, TX USA +1 (361) 289 3400

Kongsberg, Norway +47 (32) 286700

Dubai, United Arab Emirates +971 (4) 883 0303

Visit our website at www.fmctechnologies.com/measurementsolutions