

Inner Mechanism

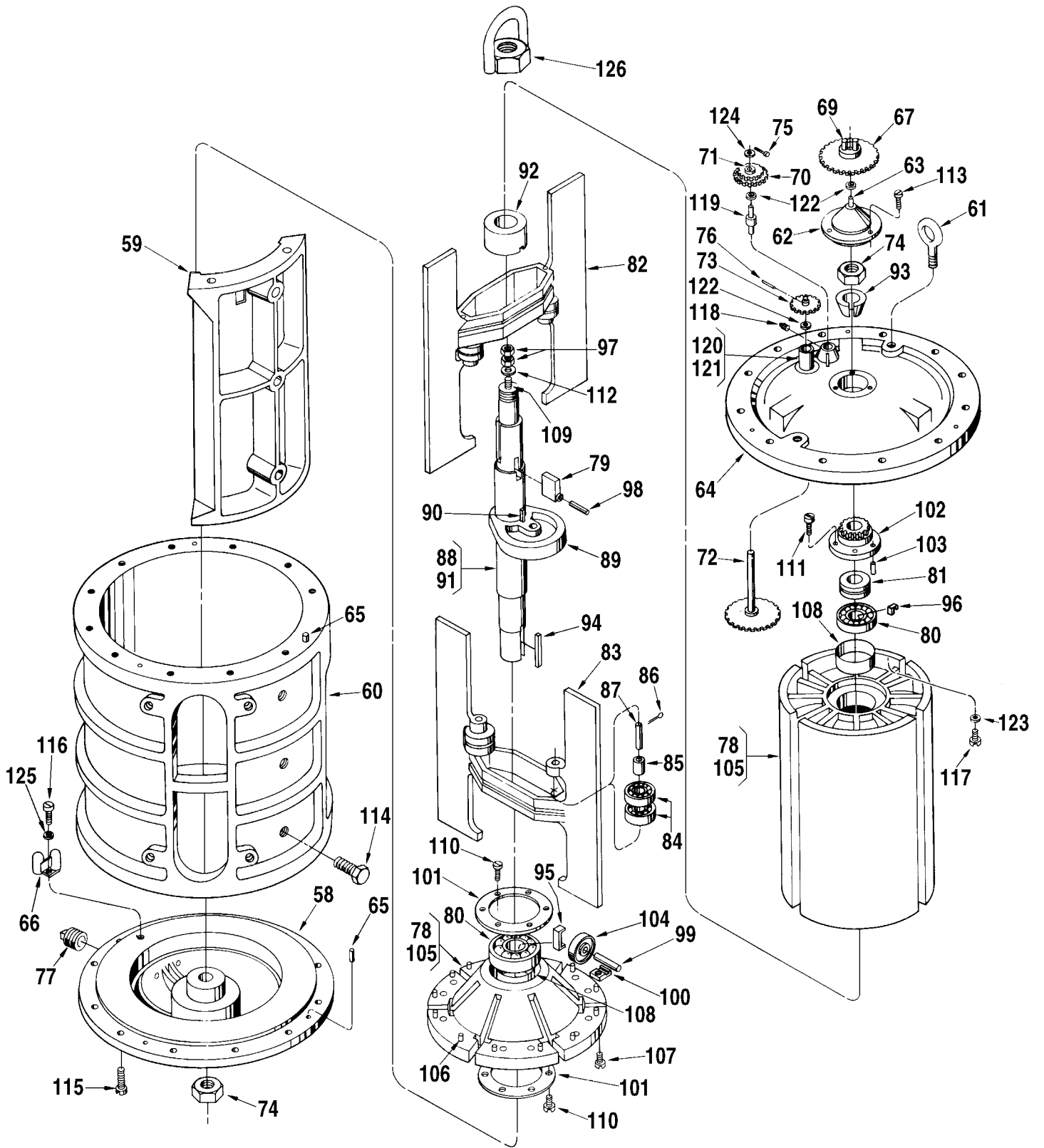

Item	Description	Qty.	JA10-S1	JA10-S3 JA10-S5	JA10-S6 JA10-S7
1	Adapter, Calibrator Adjusting	1	512372-001
2	Adapter:				
	Standard and ATC	1	518350-001	518350-002	515755-001
	ATG	1	506123-002	506123-003	516608-001
3	Blank, Snap In:				
	S6	1	015533-402
	S7	1	015533-401
4	Bolt, Eye	2	643877-401	065433-005	065433-005
5	+ Calibrator:				
	Manual	1	512059-001	512059-001	512059-001
	With ATC (Standard)	1	512060-001	512060-001	512060-001
	@1 With ATC (Special Temperature or API)	1	516130-	516130-	516130-
	Dummy Calibrator	1	516105-001	516105-001	516105-001
6	Cap, Pipe:				
	Standard	1	640259-002
	NACE	1	645238-403
7	Clamp, Oil Tube	1	003905-001	003905-001	003905-001
8	Coupling Assembly:				
	Standard, Used on 3/16" Shaft	1	005969-001	005969-001	005969-001
	Used on Xmitters with 1/4" Shaft	1	005969-002	005969-002	005969-002
9	Pin	1	003540-001	003540-001	003540-001
10	Coupling, Drive	1	072103-001	072103-001	072103-001
11	Cover:				
	S7 Only	1	517561-001
	All Others	1	500283-001	504044-001	517560-001
12	Cover, Knob	1	003553-001	003553-001	003553-001
13	Flange, Temperature Well	1	012026-001	012026-001	012026-001
14	Gasket, Temperature Well	1	060341-001	060341-001	060341-001
15	Gasket, Cover Plate	1	003834-001	003834-001	003834-001
16	+ Gasket, Packing Gland	1	011337-001	011337-001
17	+@2 Gland, Packing:				
	Standard	1	500351-001	009652-001	515849-001
	Teflon	1	500351-002	009652-002	515849-002
	NACE	1	551132-001	551439-001
18	Housing Assembly, Outer:				
	S1, S5, and S6	1	515176-001	515207-001	517568-001
	S3 and S7	1	517297-001	517569-001
	S3 and S7 NACE	1	551129-001	552098-001
19	Lubrication Assembly	1	503554-001
20	Nipple, Pipe:				
	Standard	1	643338-402
	NACE	1	645264-401
21	Nut, Hex Heavy:				
	S7 Only	48	642148-409
	All Others	48	006258-400	006385-400	006385-400
22	Oiler	1	006588-001	006588-001
23	+ O-Ring, Cover:				
	Buna-N	1	511874-001	504001-001	517552-001
	Viton	1	511874-002	504001-002	517552-002
24	+ O-Ring, Packing Gland:				
	Buna-N	1	640888-001
	Viton	1	640894-001
25	Pin, Locating Dowel	2	003348-001	003348-001	003348-001
26	Pin, Groove, 5/64 x 1/2"	1	006053-002	006053-002	006053-002
27	Plate, Caution	1	006571-001	006571-001	006571-001
28	Plate, Cover	1	003440-001	003440-001	003440-001
29	Plate, Lubrication	1	517715-001	515873-001

Item	Description	Qty.	JA10-S1	JA10-S3 JA10-S5	JA10-S6 JA10-S7
30	Plug, Pipe, 1/2" NPT:				
	Standard.....	1	006505-002	006505-002	006505-002
	NACE	1	645242-402	645242-402
31	Plug, Pipe, 2" NPT.....	1	006759-002	006759-002
32	Plug, Temperature Well.....	1	012025-001	012025-001	012025-001
33	Screw, Drive.....	8	009880-400	009880-400	009880-400
34	Screw, #10-24 x 3/4".....	2	006481-003	006481-003	006481-003
35	Screw, Adapter Cover.....	2	642043-432	642043-432	642019-416
36	Screw, Base Plate, #10-32 x 7/8".....	2	640835-001	640835-001	640835-001
37	Screw, Calibrator Mount, #6-32 x 5/16".....	2	006048-002	006048-002	006048-002
38	Screw, Cap, 5/16-18 x 3/4".....	4	006409-002	006409-002	006409-002
39	Screw, Cover Plate, #10-32 x 3/8".....	2	006045-002	006045-002	006045-002
40	Screw Nozzle to Inner Mech:				
	5/8-11 x 2".....	4	643700-401	643700-401
	5/8-11 x 3-1/4".....	4	642061-409
	NACE.....	4	645192-401	645265-401
41	Screw, Packing Gland:				
	5/16-18 x 1-1/4".....	3	006511-002	006511-002
	7/16-14 x 1-1/2".....	4	006410-002
42	+ Seal, Lead, and Wire.....	2	001627-400	001627-400	001627-400
43	Shaft Assembly, Calibrator:				
	S3, S5, and S6.....	1	501972-001	517553-001
	S7.....	1	517553-002
44	Coupling, Lower Drive.....	1	503408-001	503408-001
45	Coupling, Upper Drive.....	1	501970-001	501801-002
46	Shaft:				
	S3, S5, and S6.....	1	501971-001	517573-001
	S7.....	1	517573-002
47	Pin, Groove, 5/64 x 1/2".....	2	006053-002	006053-002
48	Stem Assembly, Adjusting.....	1	009838-001	009838-001	009838-001
49	Ball.....	2	006427-001	006427-001	006427-001
50	Plate, Base.....	1	003552-001	003552-001	003552-001
51	Plate, Retainer.....	1	003556-001	003556-001	003556-001
52	Spring, Knob.....	2	003557-001	003557-001	003557-001
53	Stem, Adjusting.....	1	003551-001	003551-001	003551-001
54	Stud:				
	S7 Only.....	24	665432-404
	All Others.....	24	065357-001	640446-001	640446-404
55	Tube, Oil.....	1	514658-001	514658-001	514658-001
56	Washer.....	4	514584-001	514584-001	514584-001
57	Washer.....	2	002917-400

Inner Mechanism

Item	Description	Qty.	Part Number
58	Base.....	1	500186-002
59	Block:		
	Standard.....	1	536590-001
	Hi-Viscosity - For 1,000 SSU to 3,000 SSU.....	1	536590-201
	Hi-Viscosity - For 1,000 SSU to 5,000 SSU.....	1	536590-202
	Hi-Viscosity - For 5,000 SSU to 10,000 SSU.....	1	536590-203
60	Body.....	1	515174-001
61	Bolt, Eye.....	2	643877-401
62	Cap, Adjusting Screw.....	1	536276-001
63	Shaft, Drive Gear.....	1	003569-001
64	Cover.....	1	536277-001
65	Dowel, Cover and Base.....	2	501205-001

Item	Description	Qty.	Part Number
66	Fitting, Pitot.....	1	072186-001
67	@3 Gear, Calibrator Drive:		
	Barrels, Standard and All Iron	1	500236-001
	Barrels, LPG.....	1	512792-001
	Hectoliters, Standard and All Iron	1	512339-001
	Hectoliters, LPG.....	1	515337-001
	Imperial Gallons, Standard and All Iron	1	516384-001
	Imperial Gallons, LPG.....	1	538397-001
68	Bushing:		
	Standard and All Iron	1	065311-001
	LPG.....	1	512797-001
69	Pin	2	500418-001
70	@3 Gear, Idler:		
	Barrels, Standard and All Iron	1	500705-001
	Barrels, LPG.....	1	512793-001
	Hectoliters, Standard and All Iron	1	505002-001
	Hectoliters, LPG.....	1	515336-001
	Imperial Gallons, Standard and All Iron	1	515664-001
	Imperial Gallons, LPG.....	1	519730-001
71	Bushing, LPG	1	512798-001
72	Gear, Jackshaft.....	1	500225-001
73	@3 Gear, Jackshaft Pinion:		
	Barrels and Hectoliters.....	1	500704-001
	Imperial Gallons	1	515661-001
74	Nut, Rotor Shaft.....	2	641997-402
75	Pin, Cotter, 1/16 x 1/2".....	1	001095-401
76	Pin, Groove, 3/32 x 1/2".....	1	006136-002
77	Plug, Pipe, 1/2" NPT.....	1	006505-002
78	Rotor and Blade Assembly:		
	Standard.....	1	537690-001
	All Iron.....	1	537690-002
	LPG.....	1	537690-003
79	Bar, Adjusting	1	536440-001
80	+ Bearing, Rotor:		
	Standard and All Iron	2	511369-002
	LPG.....	2	511369-003
81	+ Bearing, Thrust:		
	Standard and LPG	1	643999-401
	All Iron.....	1	644010-401
82	+ Blade Assembly, Upper:		
	Standard	1	536265-001
	All Iron.....	1	537517-016
	LPG.....	1	536265-002
	Std. - Modified for 1,000 SSU to 3,000 SSU	1	536265-101
	Std. - Modified for 1,000 SSU to 5,000 SSU	1	536265-102
	Std. - Modified for 5,000 SSU to 10,000 SSU	1	536265-103
	Std. - Modified for 200°F Max.....	1	536265-104
	Std. - Modified for 1,000 SSU to 3,000 SSU and 200°F.....	1	536265-105
	Std. - Modified for 1,000 SSU to 5,000 SSU and 200°F.....	1	536265-106
	Std. - Modified for 5,000 SSU to 10,000 SSU and 200°F.....	1	536265-107
83	+ Blade Assembly, Lower:		
	Standard	1	536266-001
	All Iron.....	1	537517-016
	LPG.....	1	536266-002
	Std. - Modified for 1,000 SSU to 3,000 SSU	1	536266-101
	Std. - Modified for 1,000 SSU to 5,000 SSU	1	536266-102
	Std. - Modified for 5,000 SSU to 10,000 SSU	1	536266-103

Item	Description	Qty.	Part Number
	Std. - Modified for 200°F Max.....	1	536266-104
	Std. - Modified for 1,000 SSU to 3,000 SSU and 200°F.....	1	536266-105
	Std. - Modified for 1,000 SSU to 5,000 SSU and 200°F.....	1	536266-106
	Std. - Modified for 5,000 SSU to 10,000 SSU and 200°F.....	1	536266-107
84	+ Bearing, Blade.....	4	644412-405
85	Bushing, Blade	2	512353-001
86	Pin, Cotter, 3/32 x 1-1/4"	2	006373-001
87	Shaft, Blade Bearing	2	551361-001
88	+ Cam and Shaft Assembly	1	536254-002
89	Cam	1	537215-001
90	Key	1	536255-001
91	Shaft.....	1	536253-001
92	Collar	1	536269-002
93	Cone, Shaft.....	1	536273-001
94	Key.....	1	500192-001
95	Lock, Lower Rotor Bearing	1	511374-001
96	Lock, Upper Rotor Bearing	1	537068-001
97	Nut, Adjusting Screw	2	640671-001
98	Pin, Roll, 5/32 x 1"	1	010527-400
99	Pin, Rotor Cover Roller.....	4	500197-001
100	Plate, Rotor Cover Roller Pin.....	8	500414-001
101	Plate, Lock.....	2	511372-001
102	Plate, Rotor Gear.....	1	536268-002
103	Pin, Dowel.....	1	000004-001
104	+ Roller, Rotor Cover	4	500196-001
105	Rotor, Sub Assembly:		
	Standard	1	511364-001
	Std. - Modified for 1,000 SSU to 3,000 SSU	1	511364-101
	Std. - Modified for 1,000 SSU to 5,000 SSU	1	511364-102
	Std. - Modified for 5,000 SSU to 10,000 SSU	1	511364-103
	Std. - Modified for 1,000 SSU to 3,000 SSU and 200°F.....	1	511364-105
	Std. - Modified for 1,000 SSU to 5,000 SSU and 200°F.....	1	511364-106
	Std. - Modified for 5,000 SSU to 10,000 SSU and 200°F.....	1	511364-107
106	Dowel	9	500415-001
107	Screw, Cap, 3/8"-16 UNC-2A, Drilled.....	8	642048-419
108	@4R Sleeve, Rotor:		
	Current Style	2	553575-001
	Previous Style.....	2	511375-001
109	Screw, Adjusting	1	536274-001
110	Screw, Cap, 1/4-20 x 3/4"	12	005061-400
111	Screw, Cap, 3/8-16 x 1-1/4"	6	640367-001
112	Washer, Flat.....	1	641837-401
113	Screw, Cap, 5/16-18 x 1-1/4"	4	006151-002
114	Screw, Cap, Body and Block, 1/2-13 x 1-1/2"	3	006097-002
115	Screw, 5/8-11 x 1-3/4"	24	006156-002
116	Screw, #10-32 x 1/4"	2	006110-002
117	Screw, 3/8-16 x 1/2"	1	065159-002
118	Screw, Set, 1/4-20 x 1/4"	1	006538-001
119	Shaft, Idler	1	500233-001
120	Sleeve, Assembly:		
	Standard and All Iron	1	500412-001
	LPG	1	512791-001
121	Bushing:		
	Standard and All Iron	2	519882-002
	LPG	2	512796-001
122	Washer.....	3	014012-200
123	R Washer.....	2	641838-401

Item	Description	Qty.	Part Number
124	Washer:		
	Standard and All Iron	1	009615-400
	LPG	1	060554-001
125	Washer, Lock	2	642482-406
126	Lug, Rotor Assembly Lifting.....	1	552125-001

Inner Mechanism General Assembly Numbers

Barrel Geared, Standard.....	536280-091
Barrel Geared, All Iron Trim	536280-092
Barrel Geared, LPG Trim	536280-093
Hectoliter Geared, Standard	536280-291
Hectoliter Geared, All Iron Trim.....	536280-292
Hectoliter Geared, LPG Trim.....	536280-293

+ Recommended stock.

R Indicates change since last revision.

@1 Note 1: When ordering, include product temperature range, specific or API gravity, API table used, and meter and gearing calibrator is to be used in conjunction with.

@2 Note 2: See Form No. P0605.* for component parts.

@3 Note 3: Only standard gearing is listed. For additional gearing combinations, see Gear Train Bulletin SS01027.

@4 Note 4: Apply a small amount of Loctite (Part No. 645001-401) to sleeve before installing in rotor.

* The latest edition is indicated by a 2-digit postscript (e.g., .01, .02, etc.).

The specifications contained herein are subject to change without notice and any user of said specifications should verify from the manufacturer that the specifications are currently in effect. Otherwise, the manufacturer assumes no responsibility for the use of specifications which may have been changed and are no longer in effect.

Contact information is subject to change. For the most current contact information, visit our website at www.fmctechnologies.com/measurementsolutions and click on the "Contact Us" link in the left-hand column.

Headquarters:

500 North Sam Houston Parkway West, Suite 100, Houston, TX 77067 USA, Phone: +1 (281) 260 2190, Fax: +1 (281) 260 2191

Gas Measurement Products:

Erie, PA USA +1 (814) 898 5000

Ellerbek, Germany +49 (4101) 3040

Thetford, England +44 (1842) 822900

Kongsberg, Norway +47 (32) 28 67 00

Buenos Aires, Argentina +54 (11) 4312 4736

Integrated Measurement Systems:

Corpus Christi, TX USA +1 (361) 289 3400

Kongsberg, Norway +47 (32) 28 67 00

San Juan, Puerto Rico +1 (787) 772 8100

United Arab Emirates, Dubai +971 (4) 883 0303

Liquid Measurement Products:

Erie, PA USA +1 (814) 898 5000

Los Angeles, CA USA +1 (310) 328 1236

Ellerbek, Germany +49 (4101) 3040

Slough, England +44 (1753) 571515

Barcelona, Spain +34 (93) 201 0989

Moscow, Russia +7 (495) 5648705

Melbourne, Australia +61 (3) 9807 2818

Beijing, China +86 (10) 6500 2251

Singapore +65 6861 3011

Chennai, India +91 (44) 450 4400

Visit our website at www.fmctechnologies.com/measurementsolutions