

### Mechanical Installation

The PEXP Transmitter should be installed at the lowest level in the meter accessory stack. This will minimize the amount of vibration and provide the longest and most reliable service.

Be sure drive couplings are properly engaged and that weatherproof gaskets are installed before tightening mounting screws.

### Dimensions - Inches (mm)

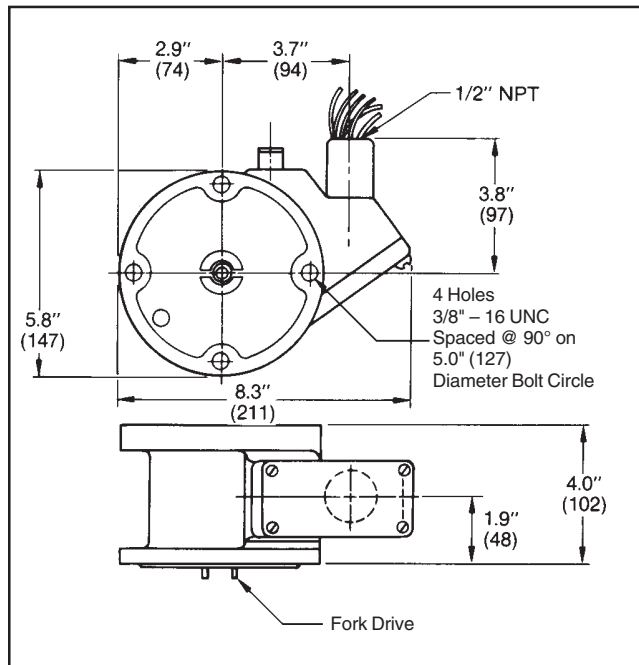

Figure 1

### Electrical Installation

A 1/2" female NPT conduit thread entry is provided on the housing the entry will have a thread protector that must be removed. A minimum of 12 inches of flexible conduit and a conduit union fitting should be used to join the housing to rigid conduit. This will facilitate later removal and replacement of the PEXP Transmitter.

#### Power Supply Requirements\*

Positive 10 Vdc @ 48 mA maximum to positive 26 Vdc @ 86 mA maximum. To help assure this voltage is available at the transmitter, the wires sizes in Table 1 should be used:



Figure 2 – PEXP in Accessory Stack

Table 1

Distance*	Wire/Size
Up to 2,000 ft. (610 meters)	#20
Up to 3,000 ft. (915 meters)	#18
Up to 5,000 ft. (1,525 meters)	#16

Multiple conductor insulated, 100% shielded cable

\*For distances greater than listed above, contact factory and advise:

- Type of instrument and if capacitive coupled.
- Output frequency at maximum flow rate - pulses/second (Hz).
- Transmission length.

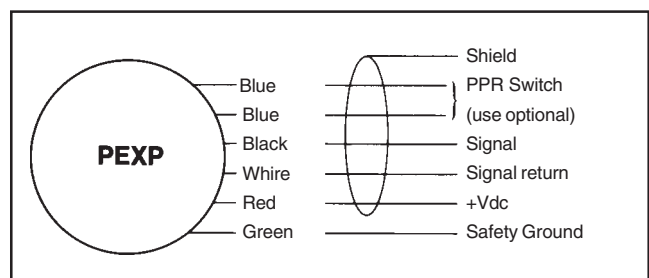

Figure 3

**Important:** Cut shield back to insulation and tape. Terminate shield at receiving instrument.

Double check all field wire connections before operation. Incorrect wiring may damage or destroy the circuitry in the PEXP Transmitter.

\*See specification Bulletin SS01051 for further information

## Mechanical Maintenance

### Temperature Range

-40°F to 158 °F (-40°C to 70°C)

All bearings in the PEXP Transmitter are self-lubricating and should require no servicing. However, there are two gears which should be lubricated annually and adjusted if necessary.

### Caution

**Extreme caution must be used when removing the cover of the PEXP to prevent damage to the reed switch that is located inside the cover plate. Follow the procedure described below while referring to Figure 4.**

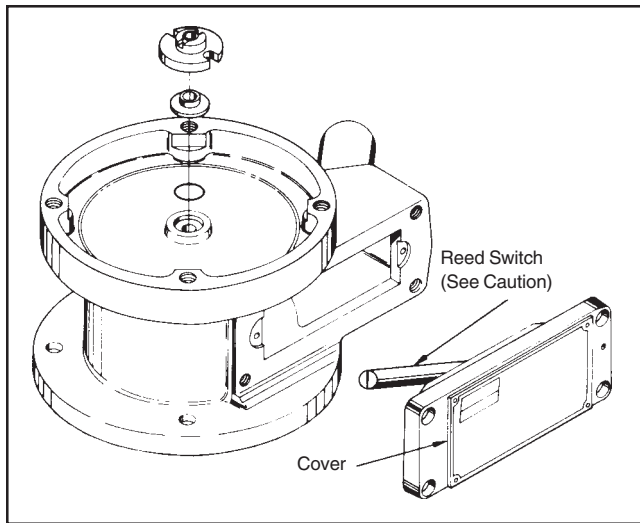

Figure 4

Material required:

Grease – Anderol L-795  
Aeroshell 14 or  
Esso Beacon 325

Allen wrench (long) – 1/16"

Screwdrivers – 1/2" blade and 1/8" blade

Procedure:

1. Remove the four cover screws and tap the cover gently to break the seal.
2. **Carefully** loosen the cover to the length of the alignment pins (0.75 in.).
3. Swing the right side of the cover away from the PEXP body **until the reed switch clears the body casting**, while holding the left side of the cover in place.
4. **Gently** remove the cover.
5. Notice that the five (5) wire connector is probably already disconnected. (Connector lead is short and probably pulled off as the cover was removed.)
6. Check gear teeth for wear or excessive backlash. Also check that the drive gear set screw is securely tightened in order to drive the shaft.
7. Adjust backlash by loosening the two screws which hold the locking plate. Turn disc post counterclockwise (eccentricity between disc post and disc shaft allow gear centers to be varied).

**Note:** There are two positions which can provide proper backlash - the correct position is obtained by rotating the post counterclockwise.

While rotating the drive fork, adjust disc post until gears begin to jam. Back off (clockwise) until gears just run smooth. Tighten locking plate and test again. Repeat until gears run smoothly with locking plate tightened.

8. Apply specified grease sparingly to gear teeth. **Do not allow grease to be smeared on slotted disc.**
9. Apply a light coating of specified grease to the cover before replacing. This provides a water-tight seal.
10. Connect the five (5) wire connector to the circuit board, locate cover guide pins and slide cover into place. Replace the four (4) screws and the seal wire.

## Electrical Maintenance

The electrical circuitry is designed to provide reliable service with a minimum of attention. Because electrical components change value during the aging process, it may become necessary to adjust the symmetry of the square wave output signal.

This can be done as follows:

Materials required:

Grease – Anderol L-795  
Aeroshell 14 or  
Esso Beacon 325

Screwdrivers – 1/2" blade and 1/8" blade

Voltmeter – Analog type (Simson 260 VOM or equivalent) or Digital (Fluke 8020 or equivalent)

Procedure:

This adjustment can be made with the PEXP Transmitter in the meter accessory stack. However, a means of providing rotation (flow) will be necessary. In order to make the symmetry adjustment, it will be necessary to measure the input voltage and use the graph (Figure 5) to arrive at the proper adjustment.

**Note:** The following voltage must be measured with the black signal wire disconnected.

Connect the positive lead of the voltmeter to the transmitter's +Vdc wire (red) and the negative lead to common (white). The voltage must be between 9 Vdc and 26 Vdc. If it is not, then the power supply voltage must be corrected. Once this voltage has been determined, connect the positive lead of the voltmeter to the

signal wire (black) of the transmitter. Rotate the PEXP at normal speed and note the voltage. The graph (Figure 5) can now be used to determine the duty cycle. The duty cycle should fall at the optimum (47-53%) point and must fall between the maximum and minimum points.

### Caution

**Extreme caution must be used when removing the cover of the PEXP to prevent damage to the reed switch that is located inside the cover plate. Follow the procedure described below while referring to Figure 4.**

1. Remove the four cover screws and tap the cover gently to break the seal.
2. **Carefully** loosen the cover to the length of the alignment pins (0.75 in.).
3. Swing the right side of the cover away from the PEXP body **until the reed switch clears the body casting**, while holding the left side of the cover in place.
4. **Gently** remove the cover.
5. Locate the trim potentiometer on the printed circuit board and adjust trim pot (1/4 turn clockwise yields 20% increase of "on time").
6. Replace the cover by reversing Steps 1-4 above.
7. Tighten the cover screws and check voltage.
8. Be sure the cover flange has a light covering of grease to ensure water tightness.
9. Repeat the adjustment until a duty cycle voltage within the 40/60 - 60/40 range is obtained, preferably at the optimum value.

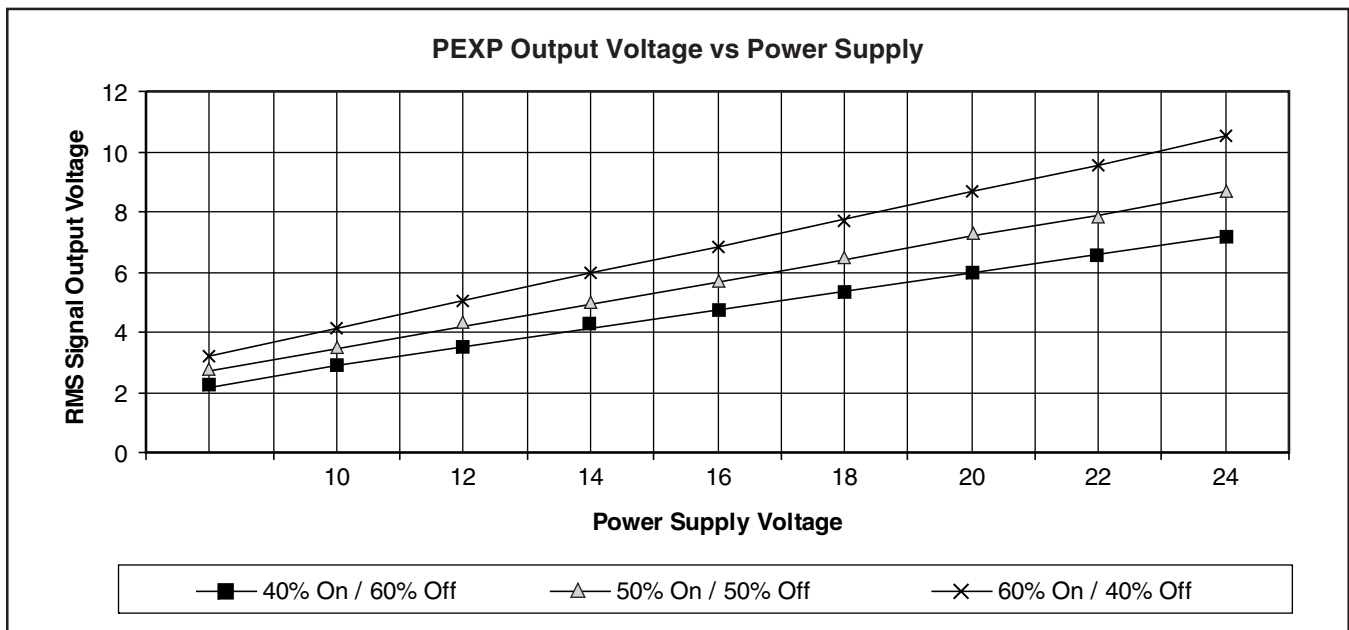

Figure 5 – Duty Cycle

## **Repair**

---

Should the PEXP Transmitter gears show excessive wear or the circuit board fails to function, they will require replacement. This is done as follows:

Material required:

Grease – Anderol L-795  
Aeroshell 14 or  
Esso Beacon 325

Allen wrench (long) – 1/16"

Screwdrivers – 1/2" blade and 1/8" blade

1/16" Punch and small hammer

### **Gears**

See Mechanical Maintenance Section for cover removal procedure. Then:

1. Remove slotted disc by removing "E" ring at the top of the disc shaft and removing clamping plate to allow disc post to be drawn from the bottom of the unit.

2. Remove drive gear by driving pin from top drive coupling, loosen the set screw in the drive gear, and draw the drive shaft from the bottom of the unit.
3. Replace the drive gear and the slotted disc and reassemble. The drive gear should be adjusted on the drive shaft so that its bottom edge is flush with the bottom edge of the slotted disc gear.

See Mechanical Maintenance Section for backlash adjustment, lubrication, and final assembly procedures.

### **Circuit Board**

The replacement of the printed circuit board requires a symmetry adjustment. See Electrical Maintenance procedure.

Revisions included in MN01020 Issue/Rev. 0.3 (10/99):  
Page 2: Revised Figure 5 - Duty Cycle

The specifications contained herein are subject to change without notice and any user of said specifications should verify from the manufacturer that the specifications are currently in effect. Otherwise, the manufacturer assumes no responsibility for the use of specifications which may have been changed and are no longer in effect.

---

#### **Headquarters:**

1803 Gears Road, Houston, TX 77067 USA, Phone: 281/260-2190, Fax: 281/260-2191

#### **Gas Measurement Products:**

**Erie, PA USA** Phone 814/898-5000  
**Thetford, England** Phone (44) 1842-82-2900  
**Kongsberg, Norway** Phone (47) 32/286-700  
**Buenos Aires, Argentina** Phone 54 (11) 4312-4736

#### **Integrated Measurement Systems:**

**Corpus Christi, TX USA** Phone 361/289-3400  
**Kongsberg, Norway** Phone (47) 32/286-700  
**San Juan, Puerto Rico** Phone 787/274-3760  
**United Arab Emirates, Dubai** Phone 971 +4/331-3646

#### **Liquid Measurement Products:**

**Erie, PA USA** Phone 814/898-5000  
**Los Angeles, CA USA** Phone 661/702-8660  
**Slough, England** Phone (44) 1753-57-1515  
**Ellerbek, Germany** Phone (49) 4101-3040  
**Barcelona, Spain** Phone (34) 93/201-0989  
**Moscow, Russia** Phone (7) 495/564-8705  
**Melbourne, Australia** Phone (61) 3/9807-2818

**Beijing, China** Phone (86) 10/6500-2251  
**Singapore** Phone (65) 6861-3011  
**Chennai, India** Phone (91) 44/450-4400

**Visit our website at [www.fmctechnologies.com](http://www.fmctechnologies.com)**