

Endstück
End piece
VZK2EN100/N

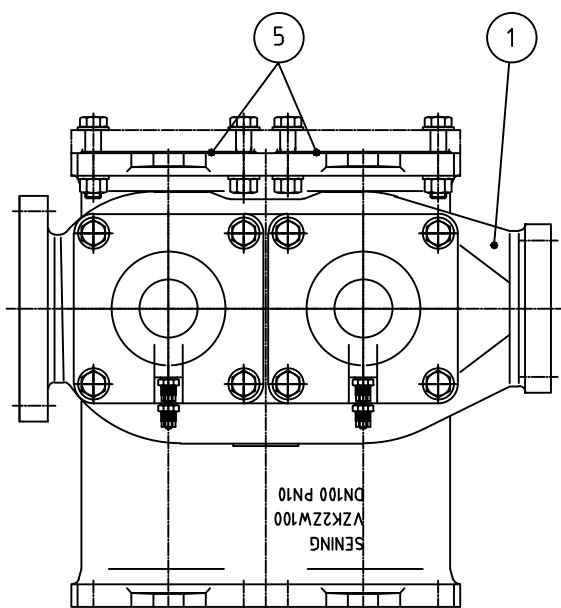

Zwischenstück ohne Abgabeanschluß
Intermediate piece without connector
VZK2ZW100/N

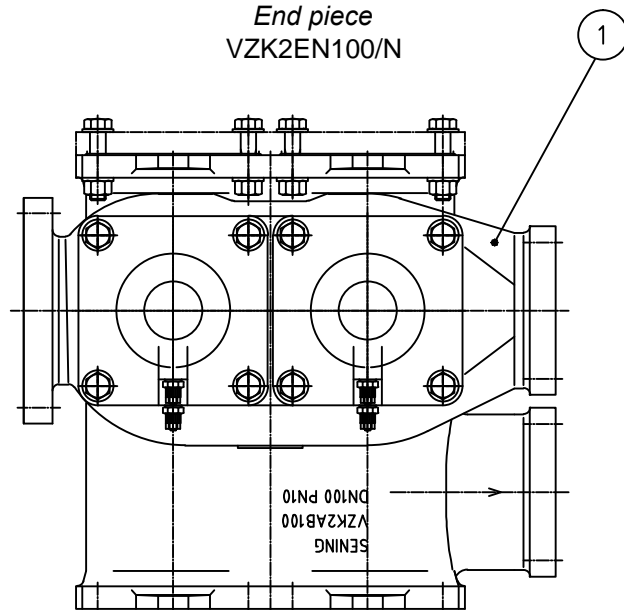

Zwischenstück mit Abgabeanschluß
Intermediate piece with connector
VZK2AB100/N

5	6000163	2	O-Ring	O-Ring
2.20	6000151	2	O-Ring	O-Ring
2	23997 D	2	Ventileinsatz	Valve insert
1	251496	1	Gehäuse für VZK2AB100N	Housing for VZK2AB100N
1	250513	1	Gehäuse für VZK2AB100	Housing for VZK2AB100
1	251495	1	Gehäuse für VZK2EN100N	Housing for VZK2ZW100N
1	250512	1	Gehäuse für VZK2EN100	Housing for VZK2EN100
1	251494	1	Gehäuse für VZK2ZW100N	Housing for VZK2ZW100N
1	250511	1	Gehäuse für VZK2ZW100	Housing for VZK2ZW100
Pos./ Item	Teile-Nr./ Part-No.	Stück/ Quant.	Benennung	Description

ALL TOLERANCED DIMENSIONS ARE FOR INSTALLATION ONLY.
ALL OTHER DIMENSIONS ARE FOR REFERENCE ONLY.

FMC Technologies

F.A.Sening GmbH, Regentstr. 1, 25474 Ellerbek, Germany

 Method 1	 Method 3	Date / Datum	Name	Item name / Benennung Verteiler 2-Kanal / Manifold dual-channel made for / zugehörig zu VZK2...
		Drawn	24.11.2010	
Scale / Maßst. 1:6		Item-No. / Teile-Nr.		Drawing No. / Zeichnungs-Nr.
Size / Format ISO - A4		VZK2...		
Weight / Gewicht kg				Rev.
				Sheet / Blatt 1
				of / von 1
				251502_71
				00B.00